

Pixel Sensors for Single Photon Detection

Contents

- Idea and basic architecture of a Hybrid Photo Diode (HPD)
 - HPD application in particle physics experiments
- Pixel detectors for X-ray astronomy in space: p-n CCD and DEPFET matrix

Hybrid Photo Diode (Hybrid Photo Detector)

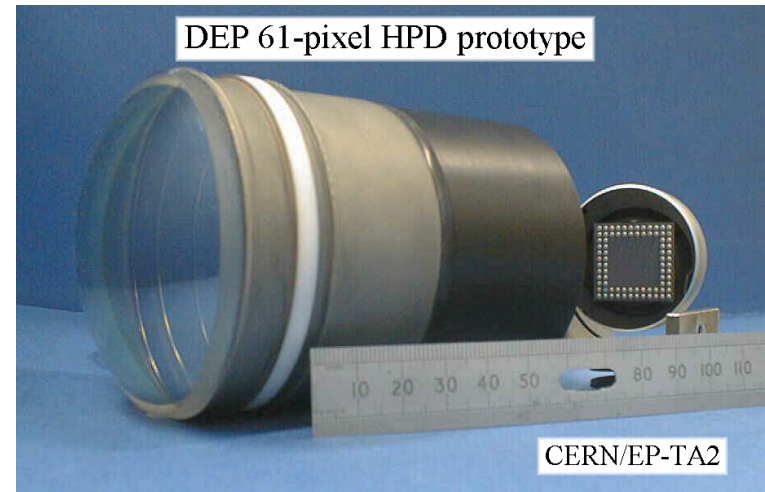
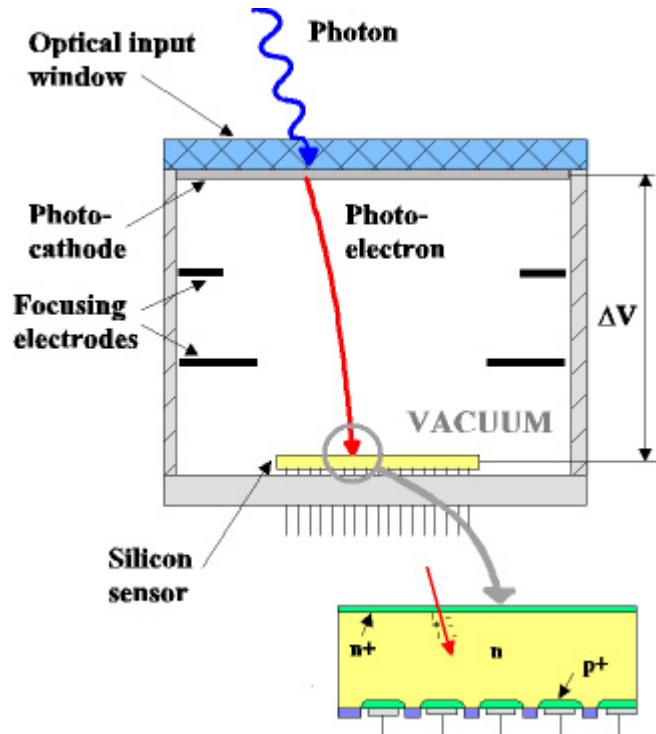

Single (visible) photon counting efficiency comes from limited QE of HPD photocathode

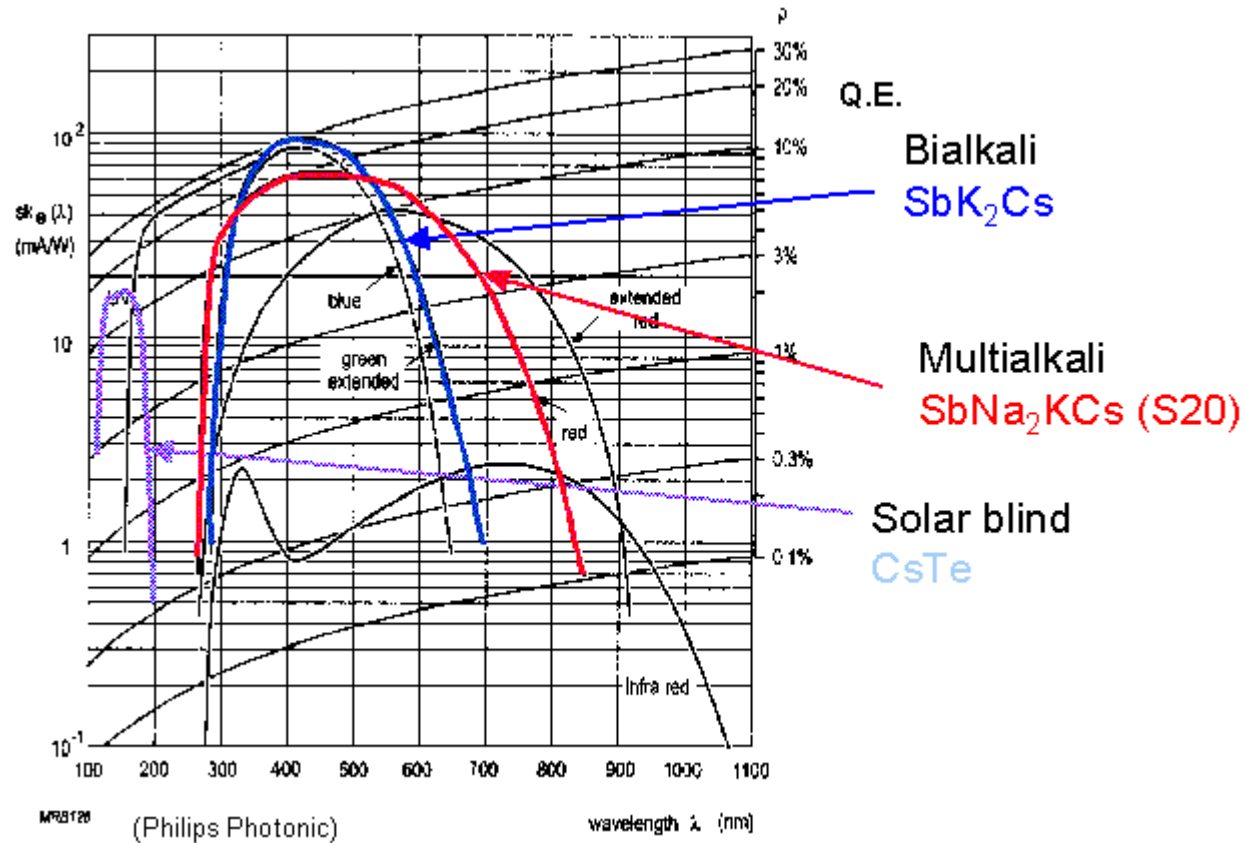

Highly-segmented silicon sensor with low noise VLSI readout electronics as an active element of HPD

134

A. Braem et al. / Nuclear Instruments and Methods in Physics Research A 442 (2000) 128–135

Fig. 6. Measured signal amplitude for single photoelectrons.

Fig. 7. Measured pulse height spectrum in ADC counts at 20 kV for an average number of photoelectrons of 0.9. The pedestal has been subtracted and a $4\sigma_{\text{noise}}$ cut has been applied.

Next logical step : silicon pixel array bump-bonded to a binary readout chip (LHC1)

M.Alemi et al., CERN-EP/99-110 (1999)

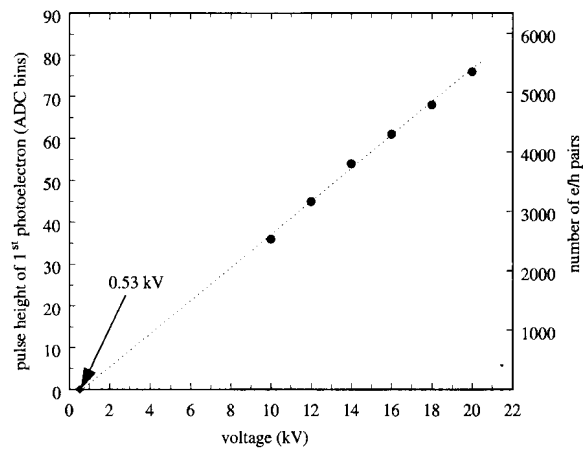
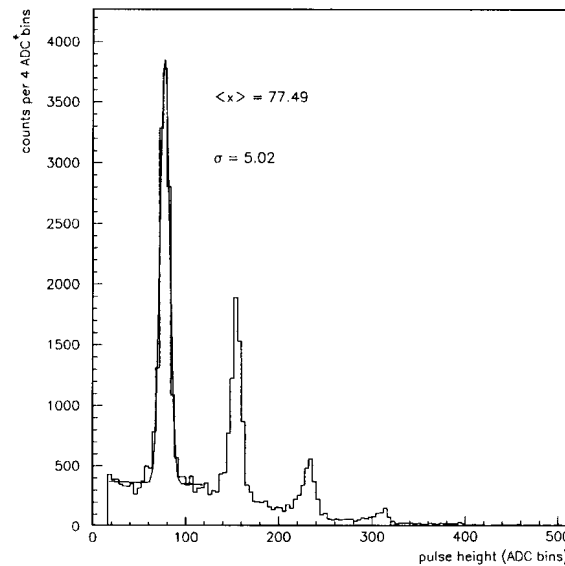
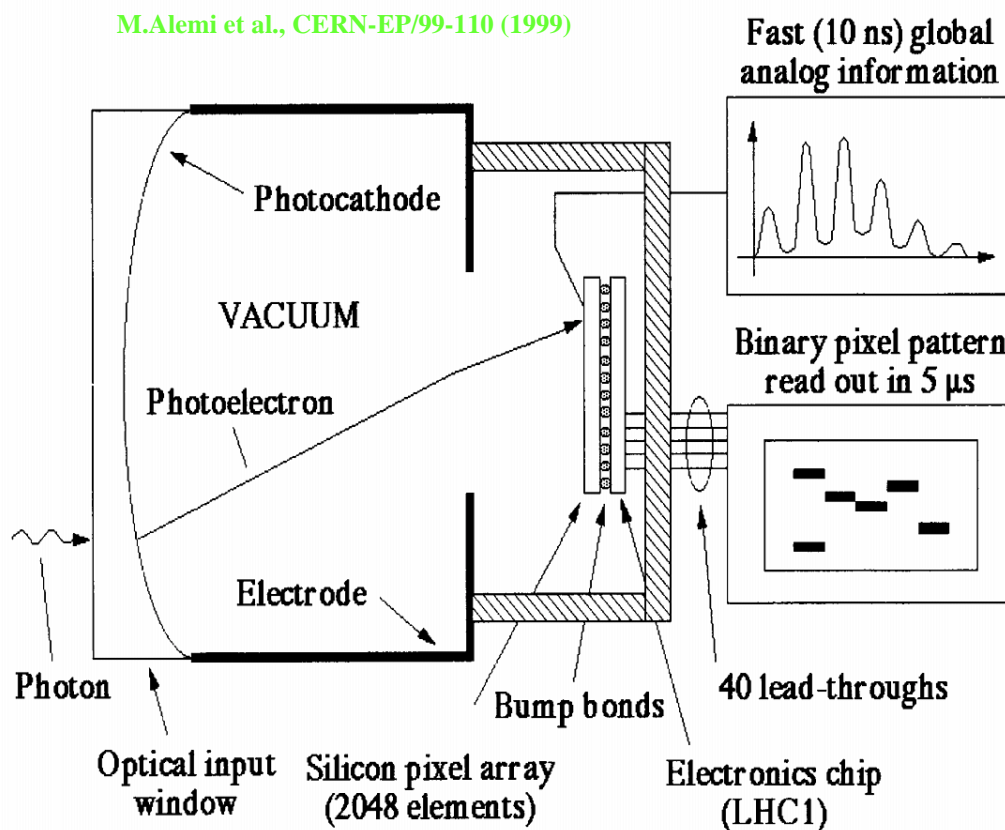

Some remaining problems before having a practical device...

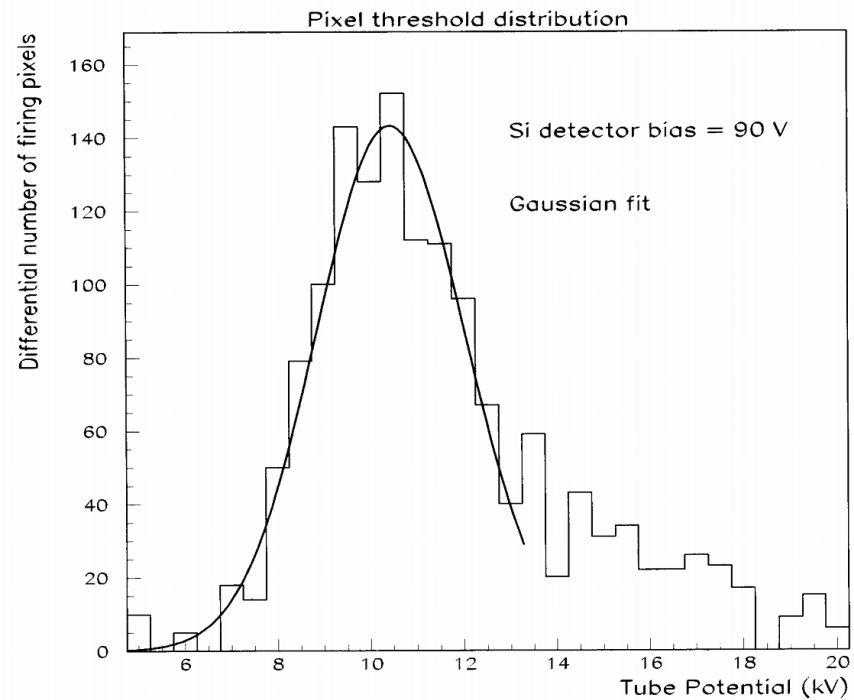

M.Alemi et al., CERN-EP/99-110 (1999)

Potential application for back-illuminated, thinned CMOS APS devices for HPD integrated sensor

- excellent noise figures
- high spatial resolution

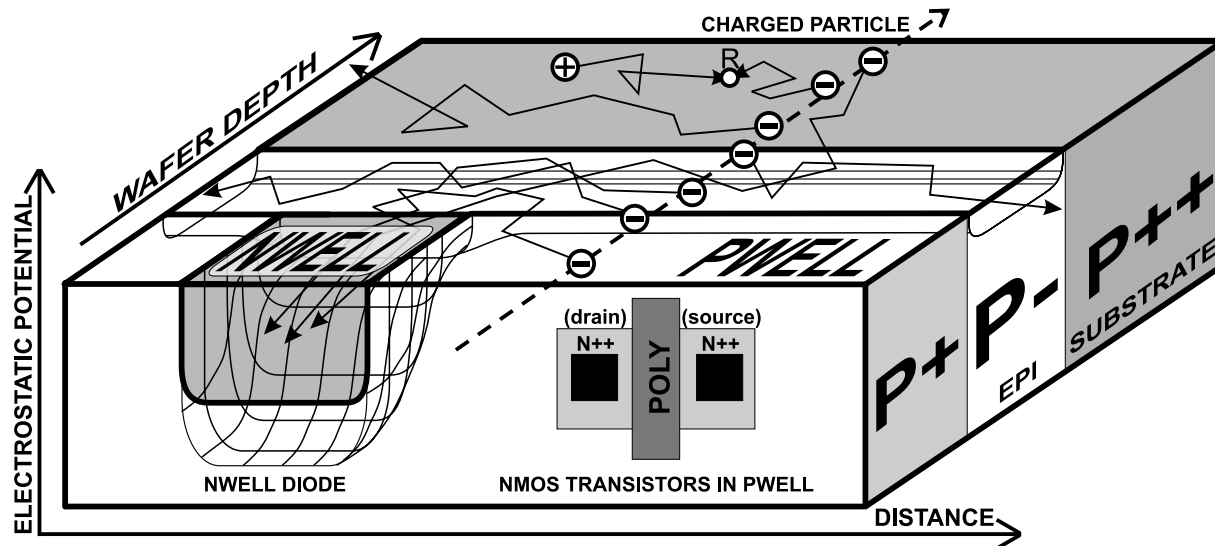

Pixel-HPD application : LHCb-RICH detector

M.Albrecht et al., NIM A 442 (2000) 164

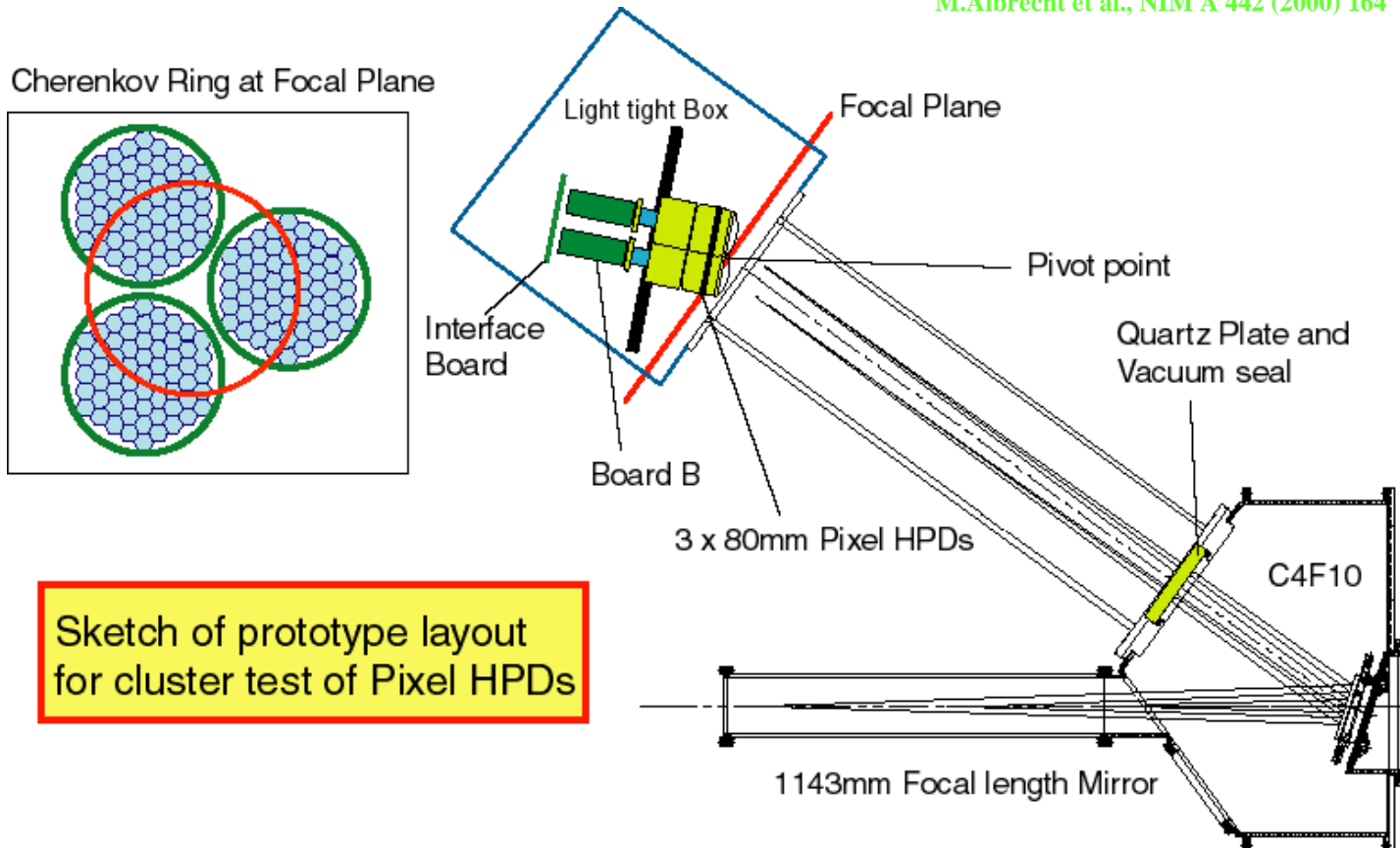

Sketch of prototype layout
for cluster test of Pixel HPDs

Cherenkov angle is 53 mrad with C4F10 radiator at 1000mbar

n.b This sketch is NOT an engineering drawing

Particle tracking using:

HPD + scintillating fibres

or

phosphor scintillator + CMOS Imager

D'AMBROSIO *et al.*: PARTICLE TRACKING WITH SCINTILLATING FIBERS

IEEE TNS Vol.43, No.3 June 1996, 2115

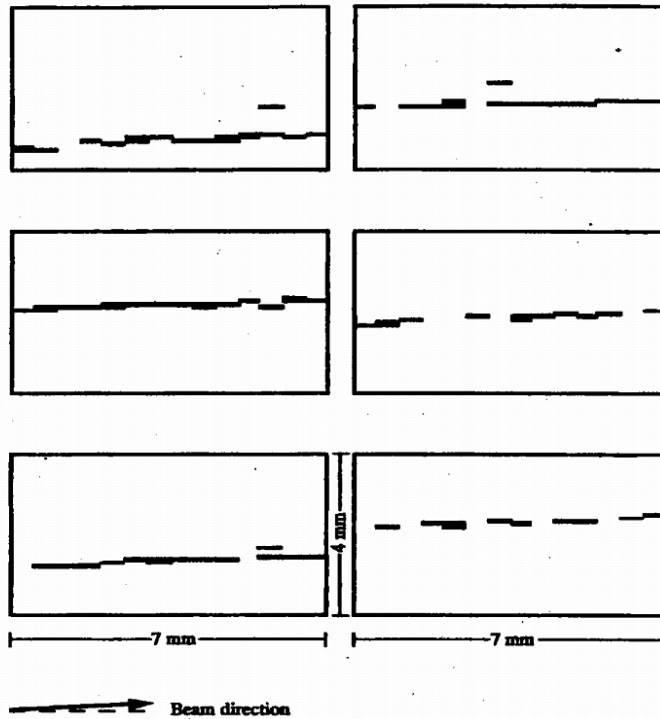
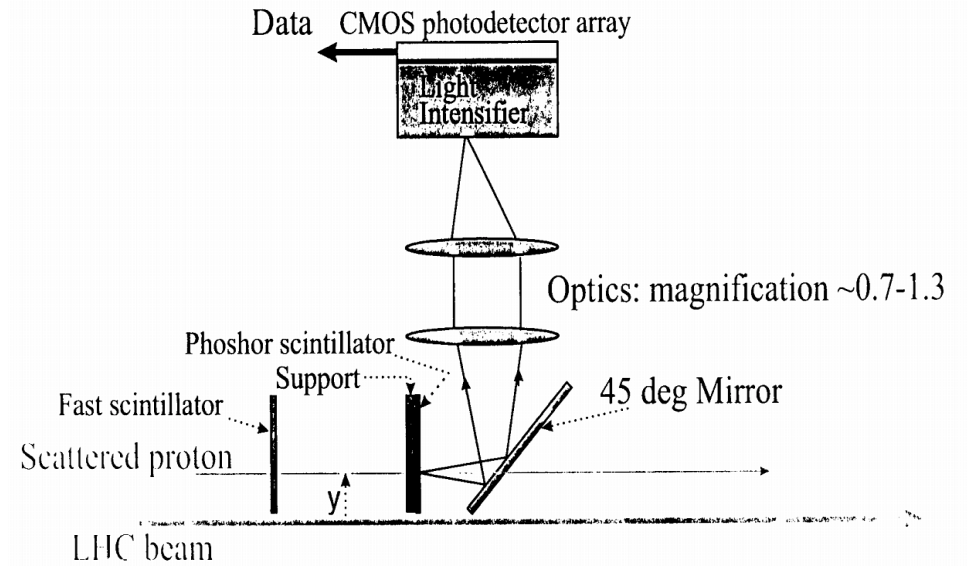

Fig. 13. Typical track patterns read out by the ISPA tube during the 120-GeV/c pion exposure. The pixel size is $75 \mu\text{m} \times 500 \mu\text{m}$ (along the beam). Occasional hits aside the tracks are attributed to δ rays. Note that the beam was not exactly parallel to the pixel edges.

TOTEM experiment at CERN LHC



Pixel-HPD application : ISPA (Imaging Silicon Pixel Array) Camera for Gamma Rays

D. Puertolas et al., IEEE TNS Vol.42, No.6
December 1996, p.2221

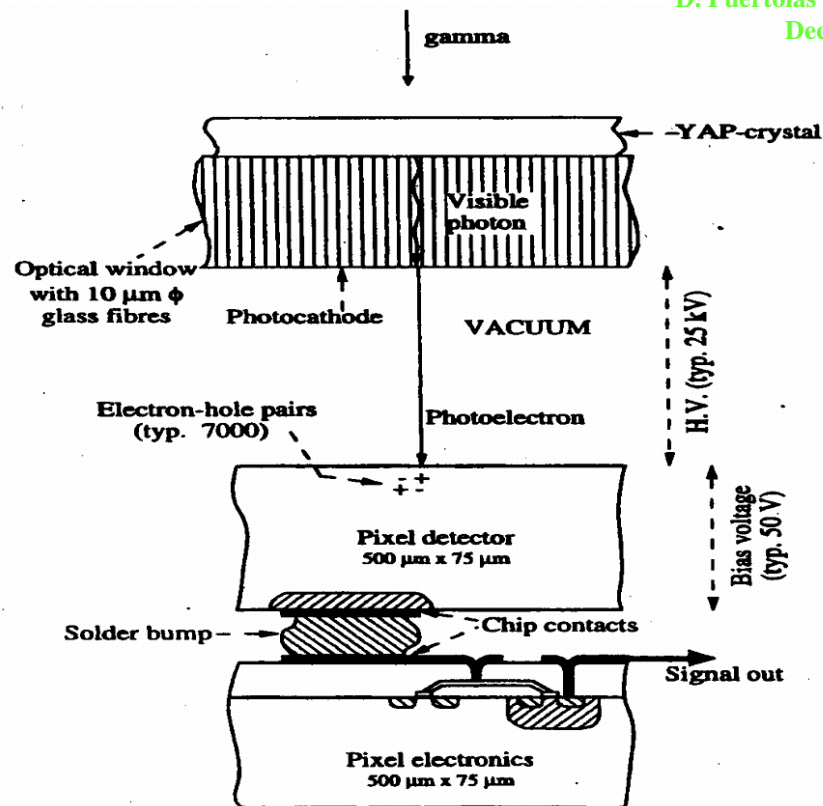
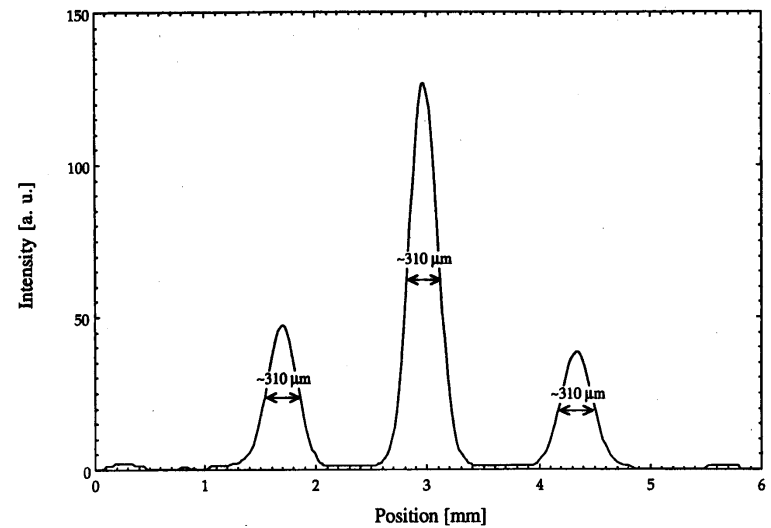
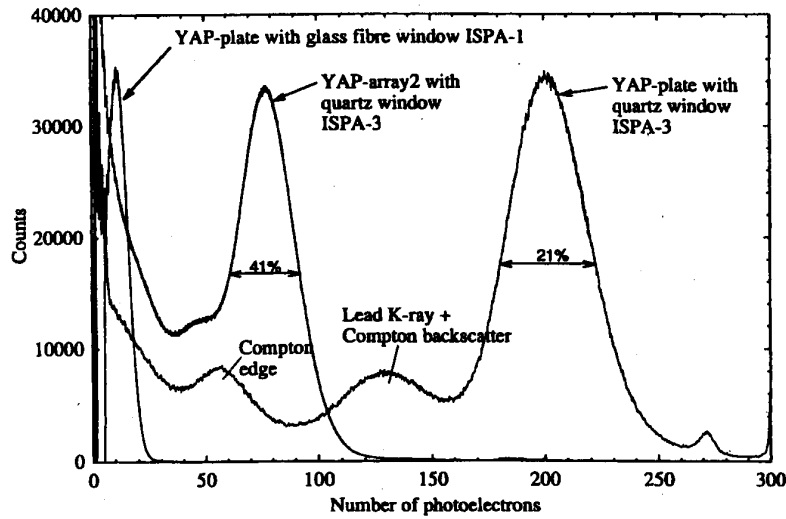

Fig. 2. Working principle of the ISPA γ -camera. The main elements for the γ -detection are represented (figure not to scale).

ISPA Camera for Gamma Rays

energy resolution (122 keV) and spatial resolution



D. Puertolas et al., IEEE TNS Vol.44, No.6
October 1997, p.1747

Fully Depleted pn-CCD

- derivative of the silicon drift detector (Gatti and Rehak, 1983)
 - JFET electronics integrated (1993)
- large area detectors (1995-1997) for (soft) X-ray astronomy in space

**Fully depleted detector volume (silicon, 300 mm thick) +
extremely low noise level (ENC ~5 el.) =
high quantum efficiency (single photon counting mode)**

pn-CCD : principal features

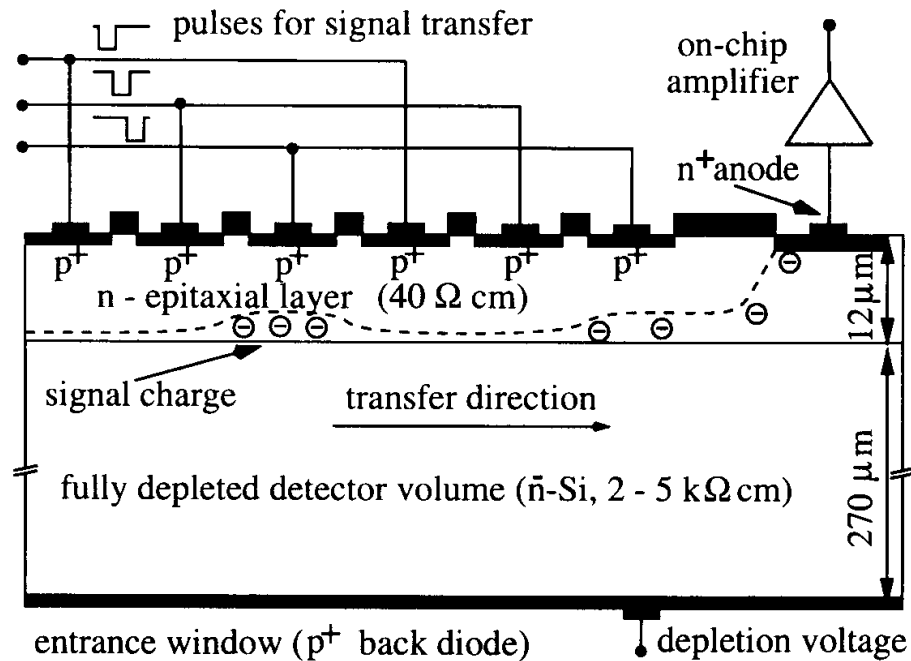

Figure 1. A schematic cross section through the pn-CCD along a transfer channel. The device is back illuminated.

P.Hall et al., SPIE, 3114: 126-133, 1977C

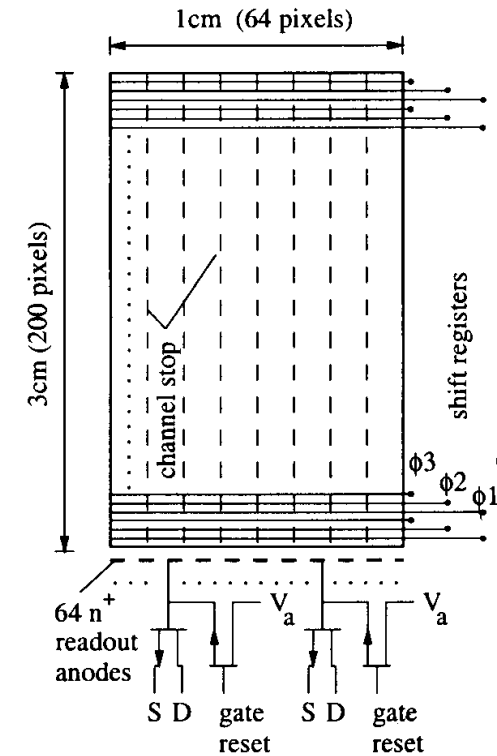

Figure 2. One pn-CCD subunit with 64 on-chip amplifiers and a size of $3 \times 1 \text{ cm}^2$.

pn-CCD : QE + Fe spectrum

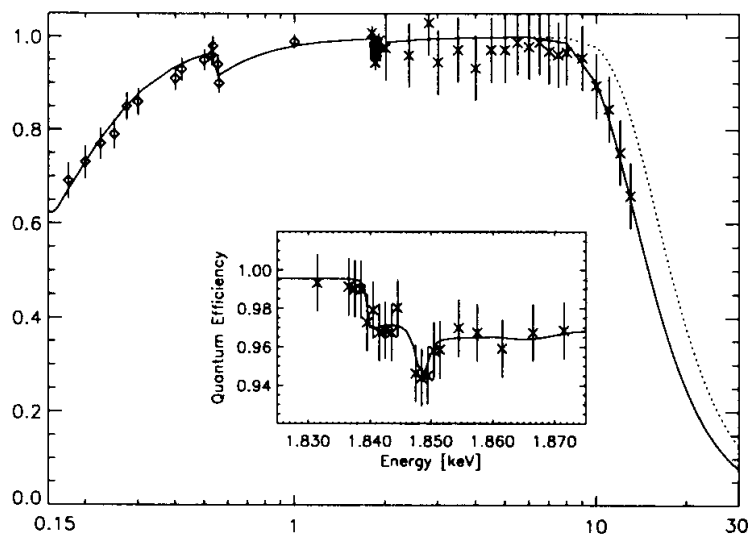

Figure 5. Quantum efficiency of the pn-CCD. The solid line represents a 300 μm thick sensitive volume, the dotted line 500 μm .

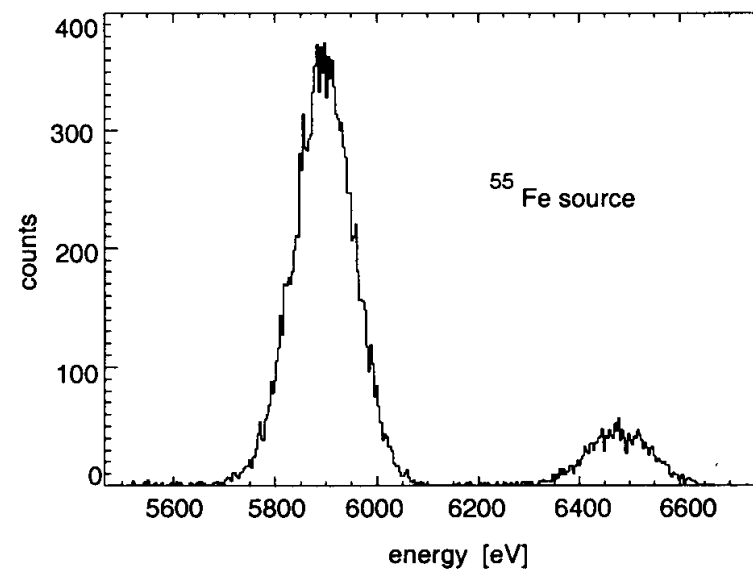

Figure 6. Mn K_{α} spectrum of an ^{55}Fe source. The measured FWHM is 130 eV at -120°C .

pn-CCD : for X-ray Astronomy: XMM-Newton Observatory

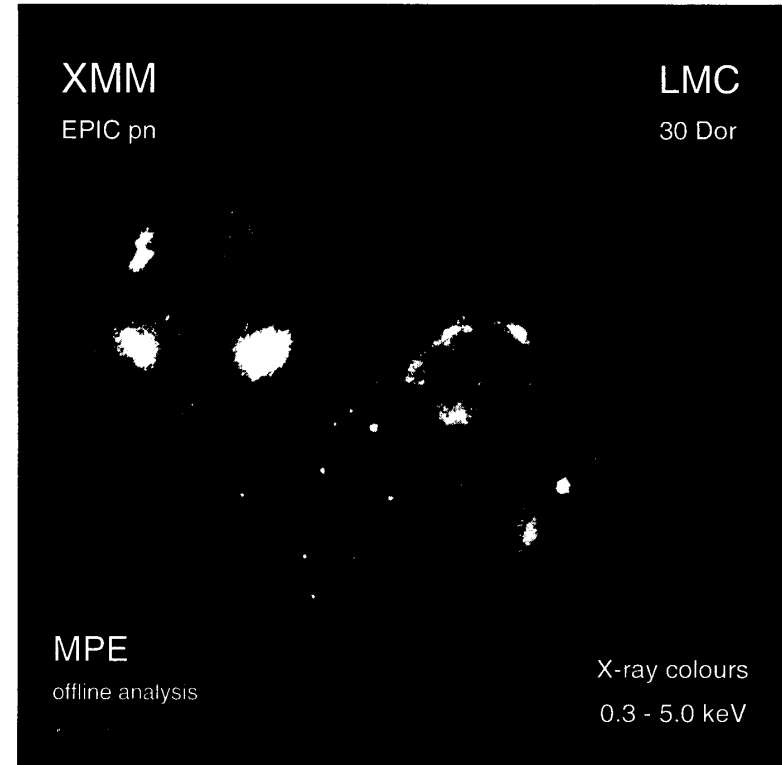
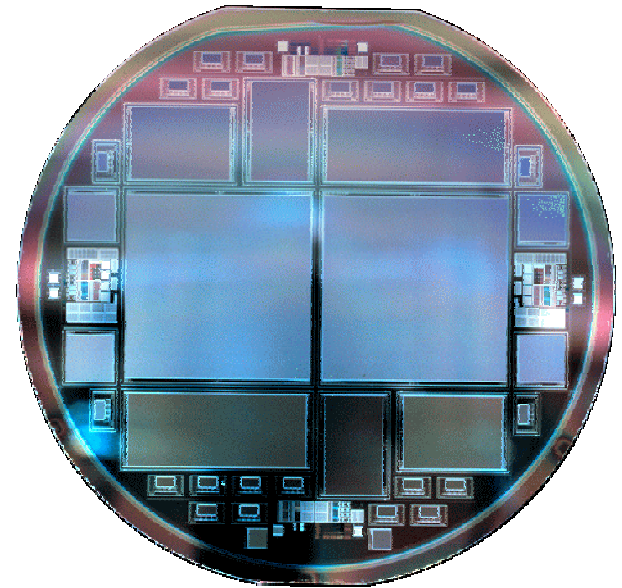
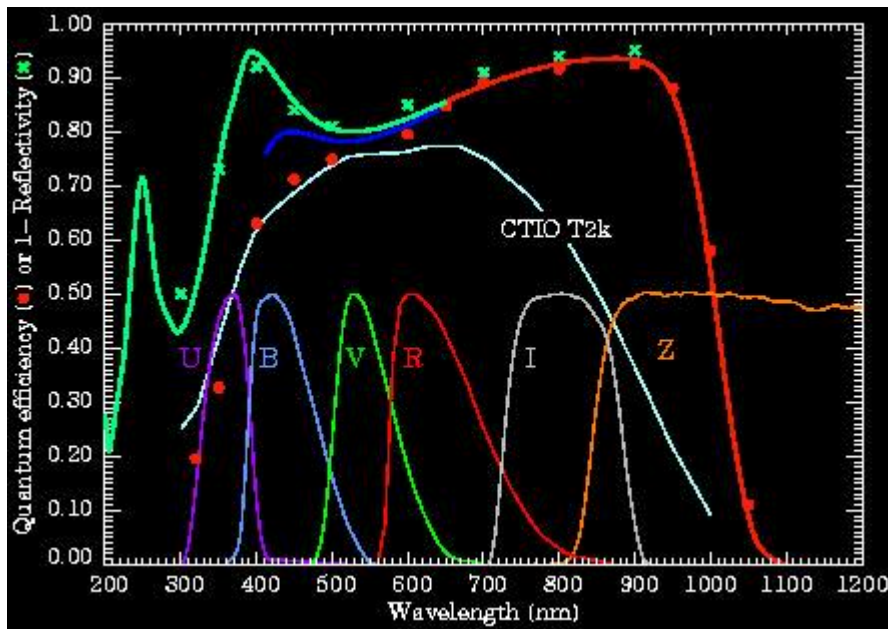

Figure 7. *The Large Magellanic Cloud in X-rays. First Light Image of the pn-CCD camera.*

Use of a high-energy physics detector technology : Back-illuminated, fully-depleted CCD image sensors for use on optical and near-IR astronomy

D.E.Groom et al, NIM A 442 (2000) 216



DEPFET Pixel Sensor for X-rays

- can be back illuminated, can have a fill factor of 1, can be made very large (all pros of CCD)
- does not need a charge transfer, no out-of-time events, every pixel is xy-addressable (all pros of APS)
- in addition, can have a non destructive multiple readout to reach very low noise figures

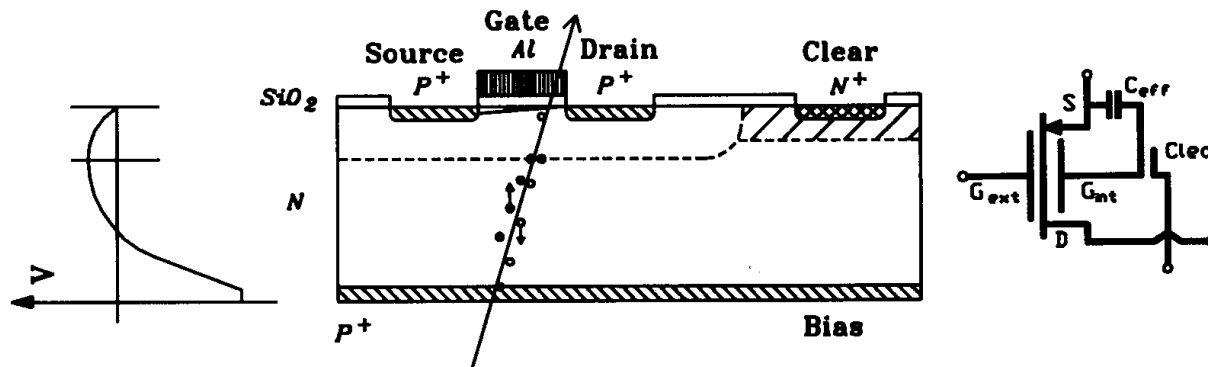

Device concept:
combination of FET
transistor with sideward
depletion (drift chamber)

Figure 1. The DEPFET structure and device symbol

J.Kemmer, G.Lutz et al. NIM A 288 (1990) 92

DEPFET as pixel detector

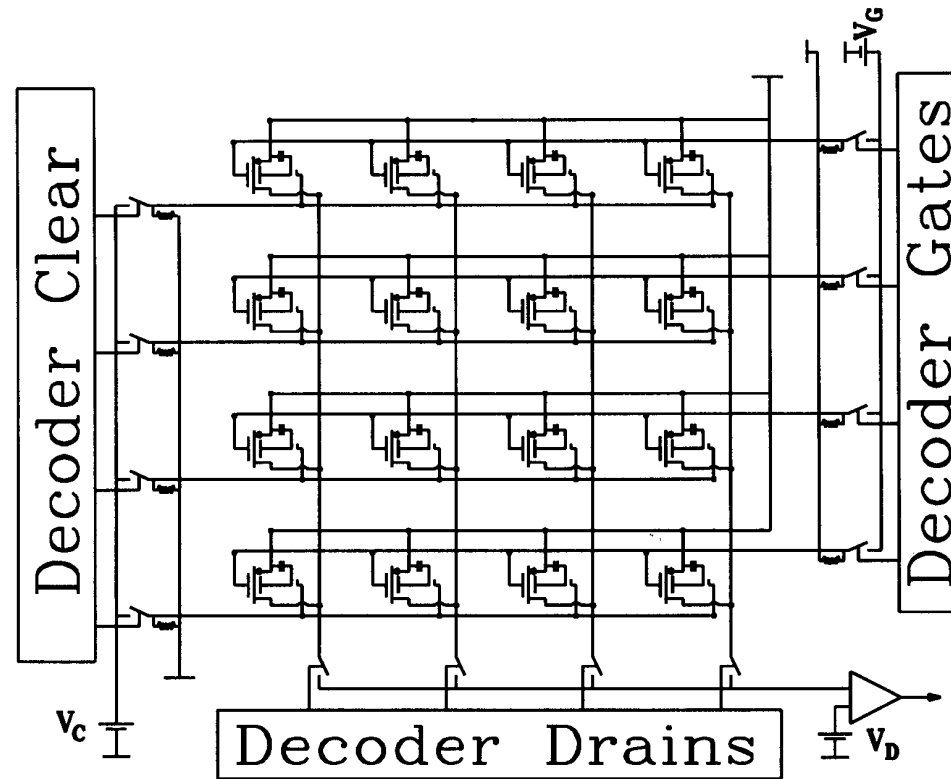
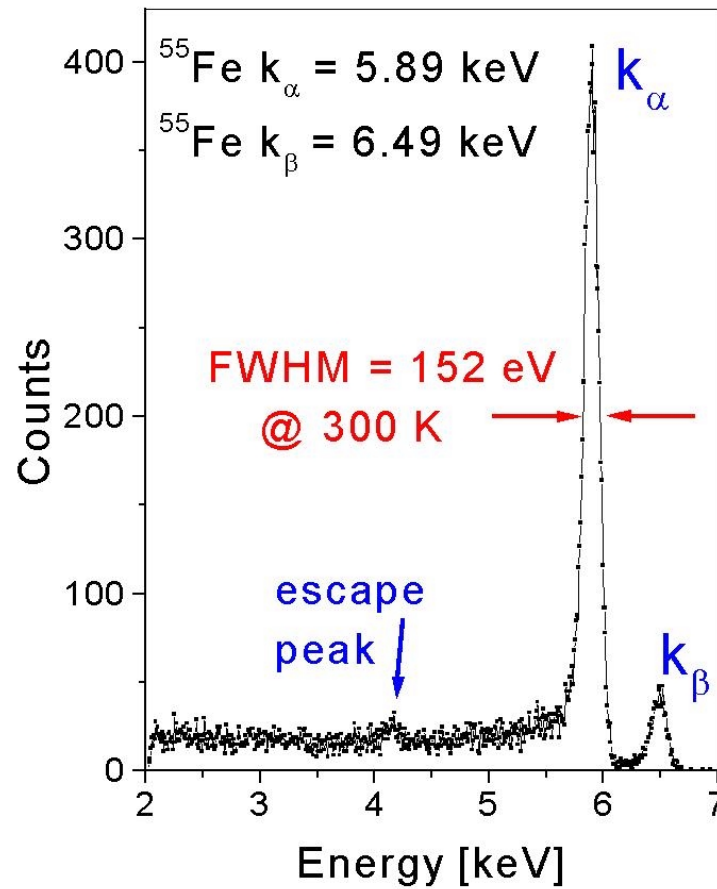

Figure 2. The circuit diagram of a DEPFET matrix

**DEPFET : excellent noise figures (9 electrons rms.)
at room temperature!**



Instead of conclusion and prospects...

Posted: 2 Jun 2000

Quantum dots detect single photons

A single-photon detector based on quantum dots has been developed for the first time by researchers at Toshiba's European laboratories in the UK.

Conventionally single photons are detected by multiplying a photo-generated electron using an avalanche process. The Toshiba researchers, in collaboration with Cambridge University, developed a device for detection of single photons based on a GaAs/AlGaAs modulation doped field effect transistor (MODFET) which does not rely on avalanche processes.

[SPIE Web](#)

Acknowledgements

**I'm very grateful to Thierry Gys (CERN) and Gerhard Lutz (MPI),
for their efficient help in the preparation of this talk!**