

30 Mrad(SiO₂) radiation tolerant pixel front- end for the BTeV experiment

A. Mekkaoui, J. Hoff

Fermilab, Batavia IL

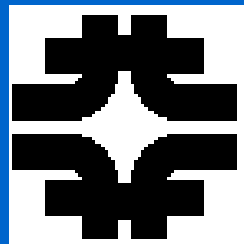

Fermilab

FPIX History

- 1997: FPIX0, a 12X64 HP 0.8u process
 - Two stage front-end, analog output digitized off chip
 - A data driven non-triggered RO
 - Successfully used in beam tests
- 1998: FPIX1, a 18X160 Hp 0.5u process
 - Two stage front-end, with one 2b FADC/cell.
 - Fast triggered/non triggered RO
 - successfully used in beam tests
- 1999: preFPIX2_T, 2X160 TSMC 0.25u (to be presented today)
 - Radiation tolerant techniques forced us to design a new front-end with a new leakage compensation strategy.
- 2000: preFPIX2_I, 18X32 0.25u CERN process (In fab)
 - Same as FE cell as in preFPIX2_T but with complete fast non-triggered RO.



FPIX1 front-end

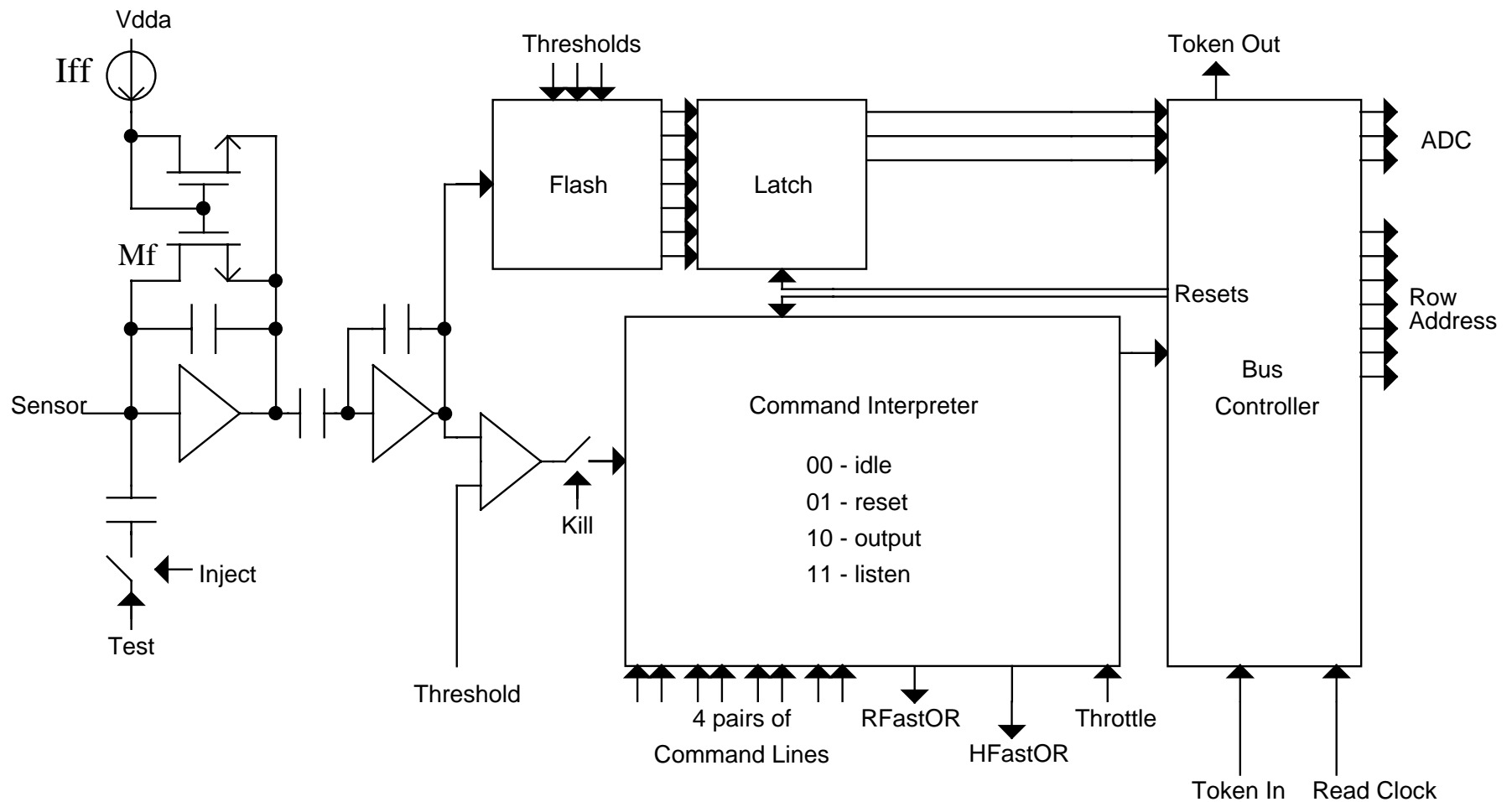

See the proceedings of the 1999 workshop on the electronics for the LHC (Snowmass) and references therein.

Main radtol design constraints

- The feedback structure used two NMOS devices and a biasing PMOS device (as a current source Iff).
- In the previous design: stability, noise and proper shaping relied on having a long ($W/L \ll 1$) N-channel device in the feedback (Mf).
- Leakage current tolerance insured by the feedback structure.
- Problems to implement present DSM radtol design:
 - NMOS in 0.25μ has higher transconductance than in 0.5μ process.
 - Minimum enclosed NMOS has W/L around 2.5. (See the RD49 reports.)
 - Enclosed NMOS with its required guard ring occupy large area.



It's quasi impossible to implement the present design in the available area.



Feedback solution

- One NMOS feedback transistor biased by a global voltage V_{FF} .
- V_{FF} generated such as to track (to the 1st order) the preamp DC level shifts due to global changes (process, temperature...)
- Feedback is current controlled as before. This current can be much higher than in the previous scheme.
- It is more reliable to work with higher currents.
- Leakage current compensation assured by a separate scheme (next slide).

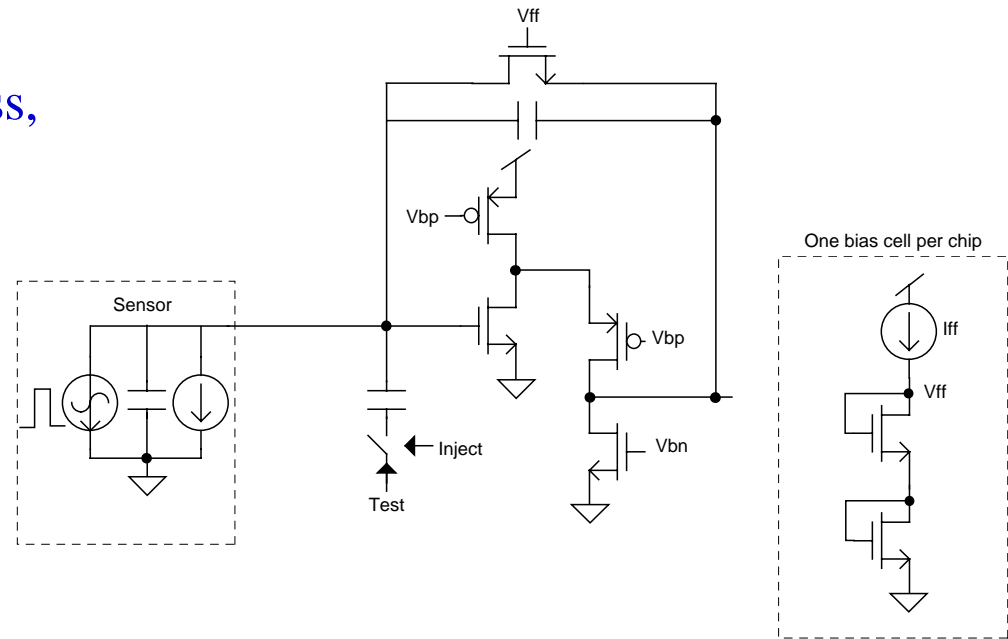

Leakage current compensation scheme

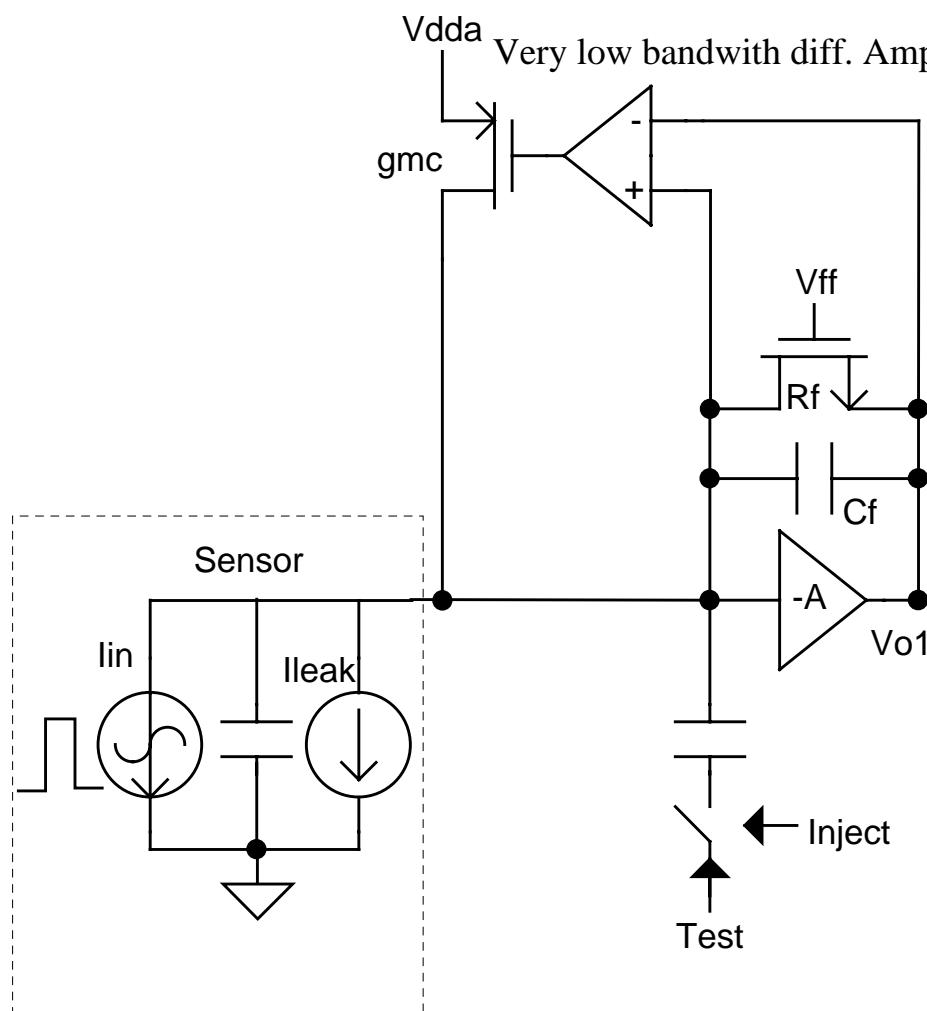

=> Compensates only one polarity.

=> The new scheme, though more complex, occupies a modest area

Leakage current compensation scheme

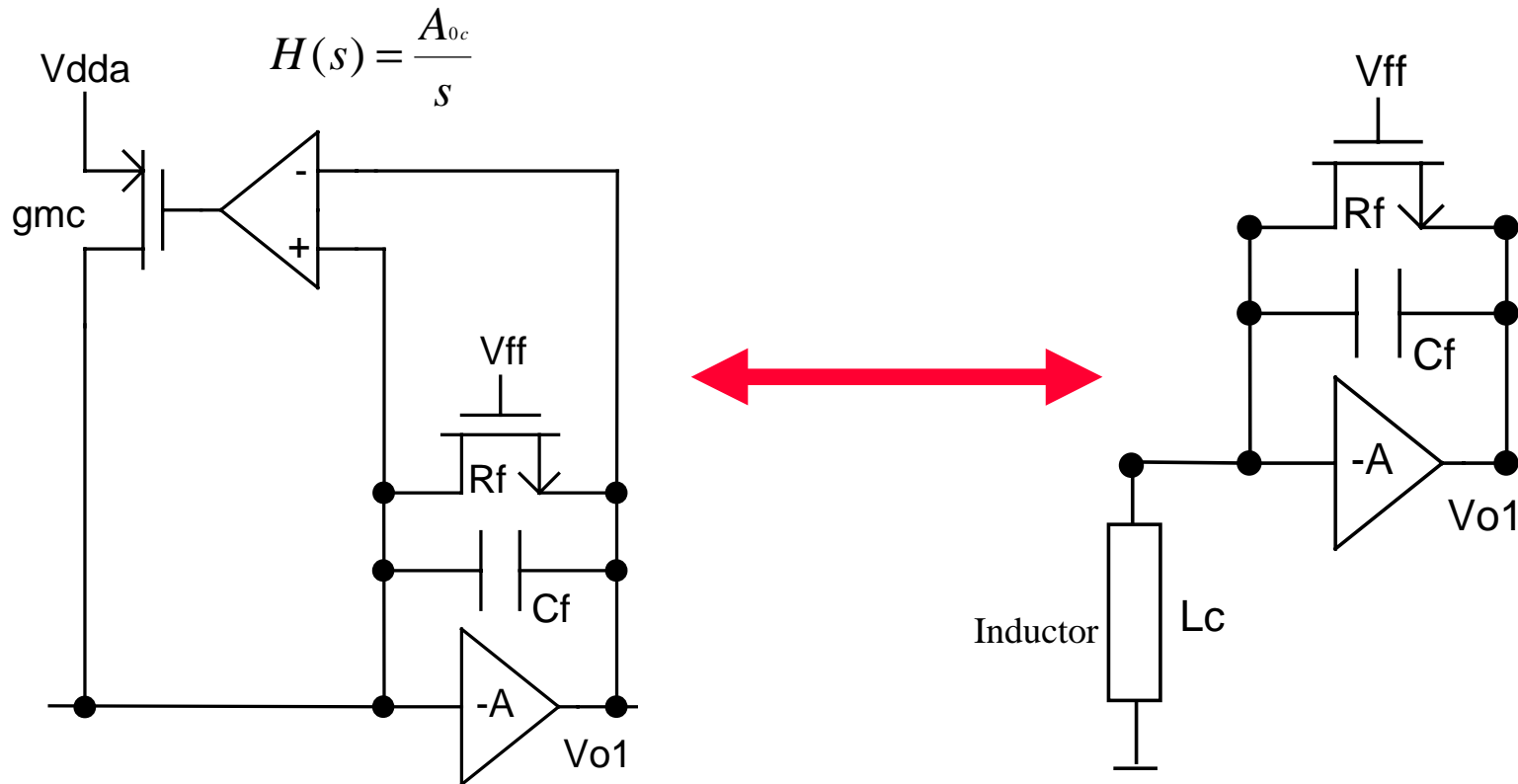

TSMC && the “CERN process”

- After some comparative work we decided to constrain our design to work well whether implemented in the “CERN” or TSMC process.
- Minor additional layout is required to submit to both processes (mostly through automatic generation)
- TSMC is offered by MOSIS (4 runs/year). 6 runs/yr is planned.
- It is wise to have a 2nd source for production.

=> CERN process is the process selected by CERN to implement their deep sub-micron radtol designs.



preFPIX2

- preFPIX2 is the first prototype we designed to investigate our ideas and to test the radiation hardness of the TSMC 0.25 μ process. It contains 8 pixel front-end cell and several isolated transistor.

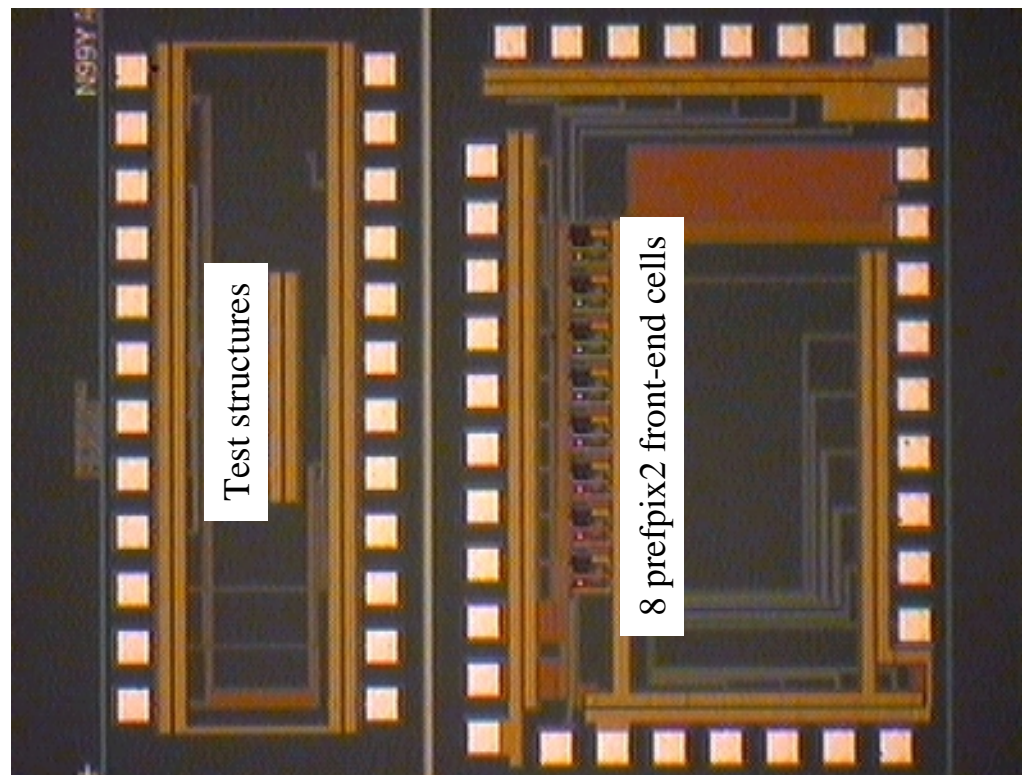

Typical front-end response

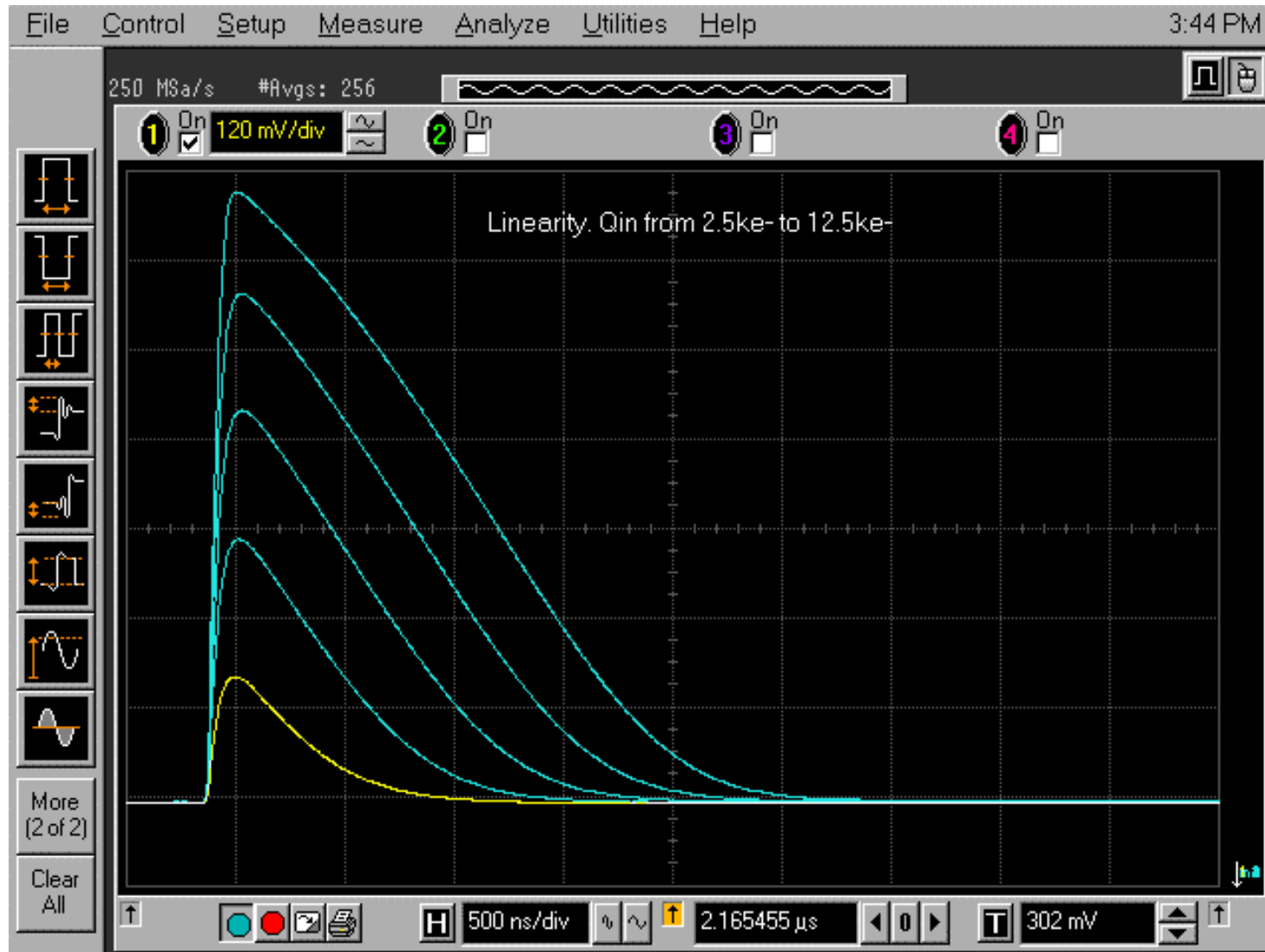

Buffered output of the second stage

Feedback control

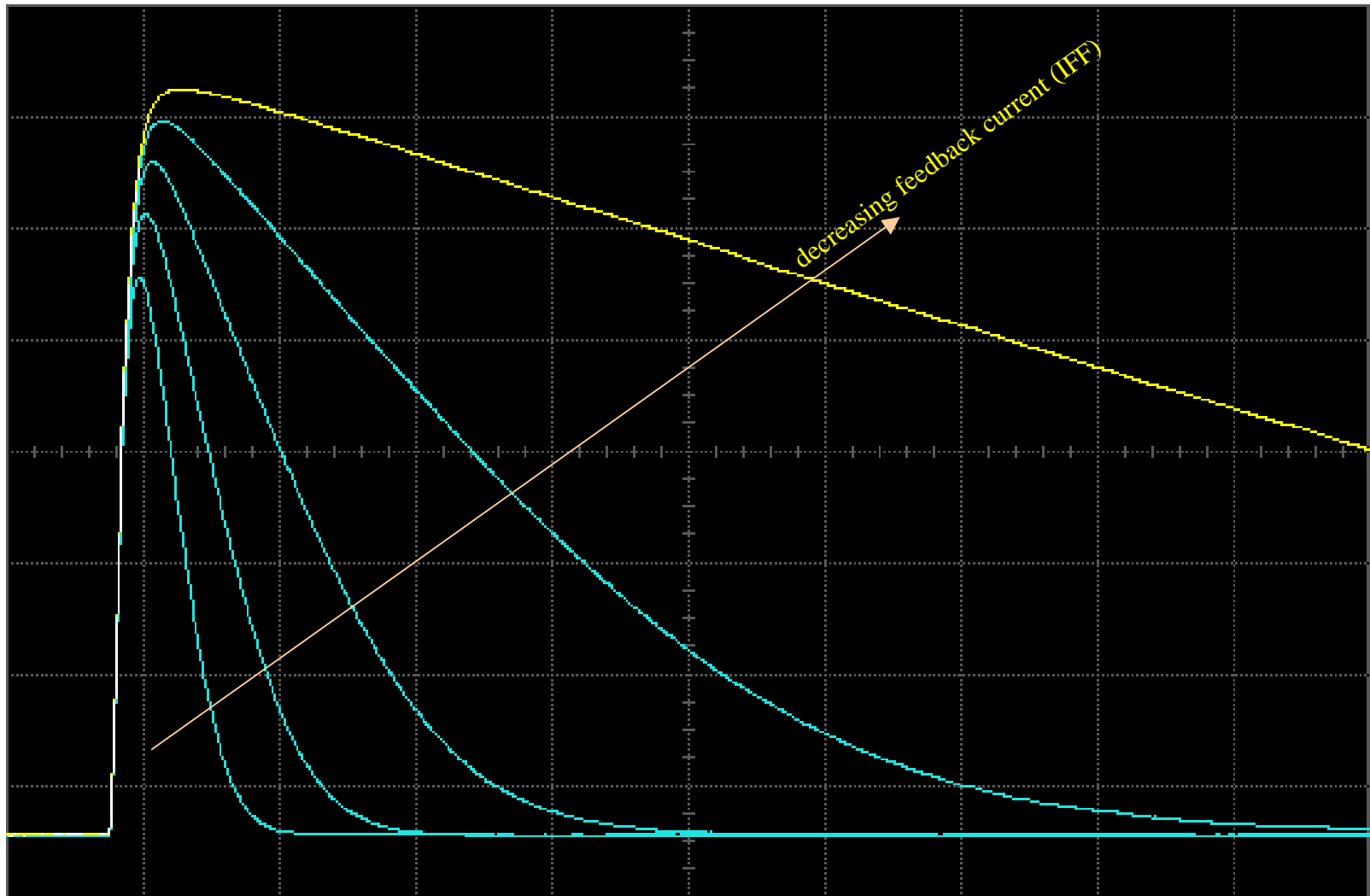

Feedback control

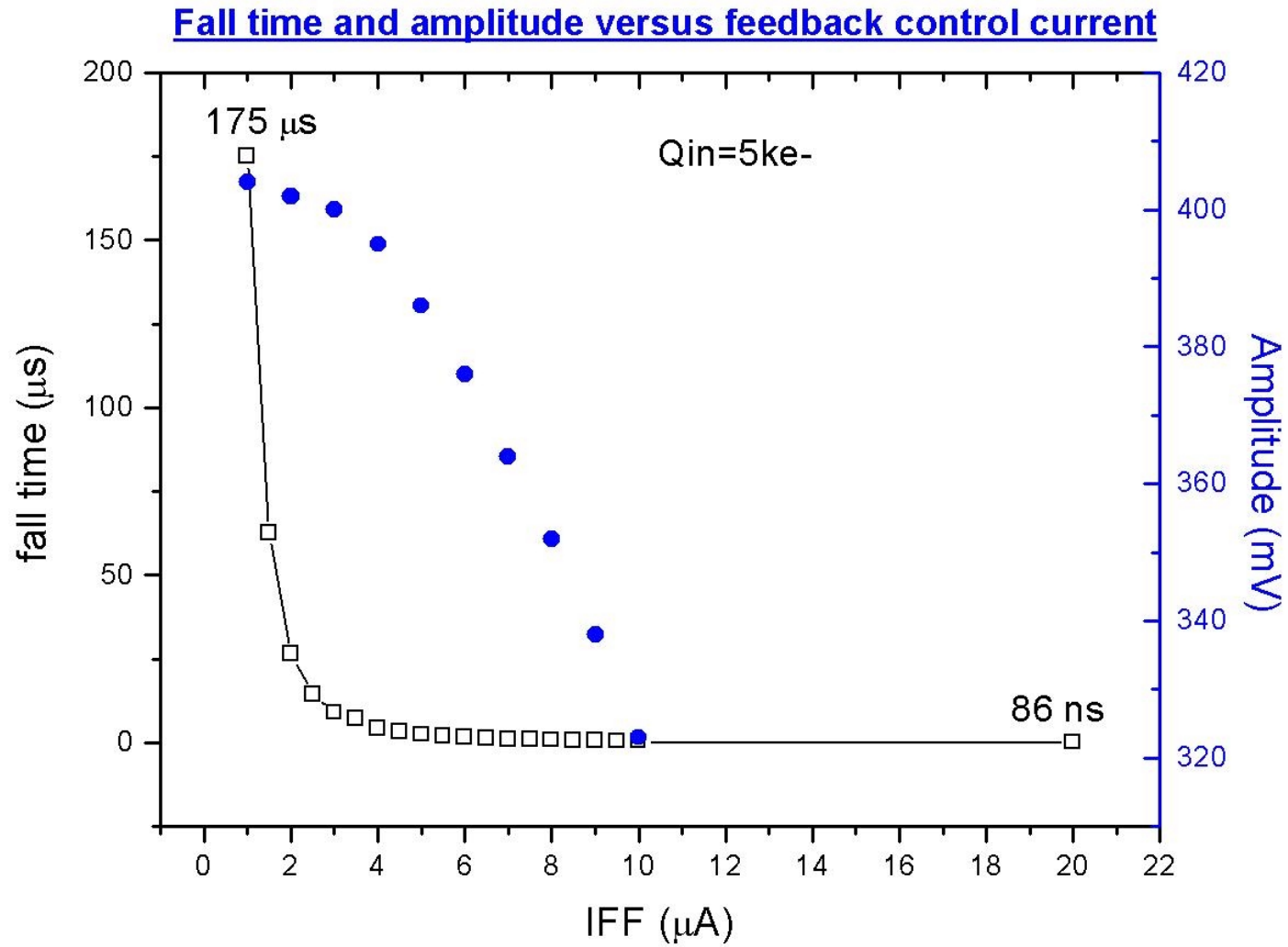

Feedback control

Fall time and ENC versus feedback control current

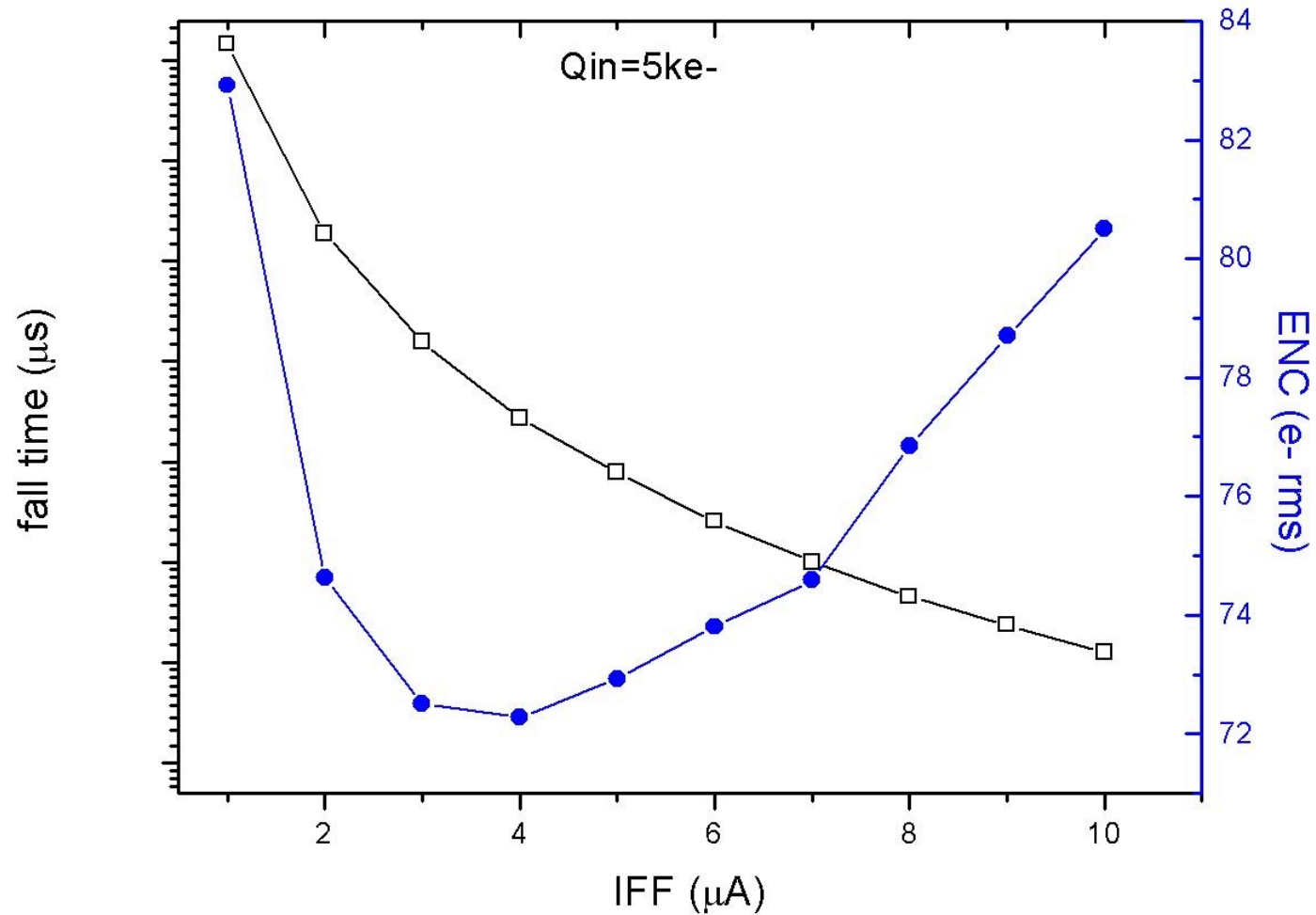

Leakage current compensation

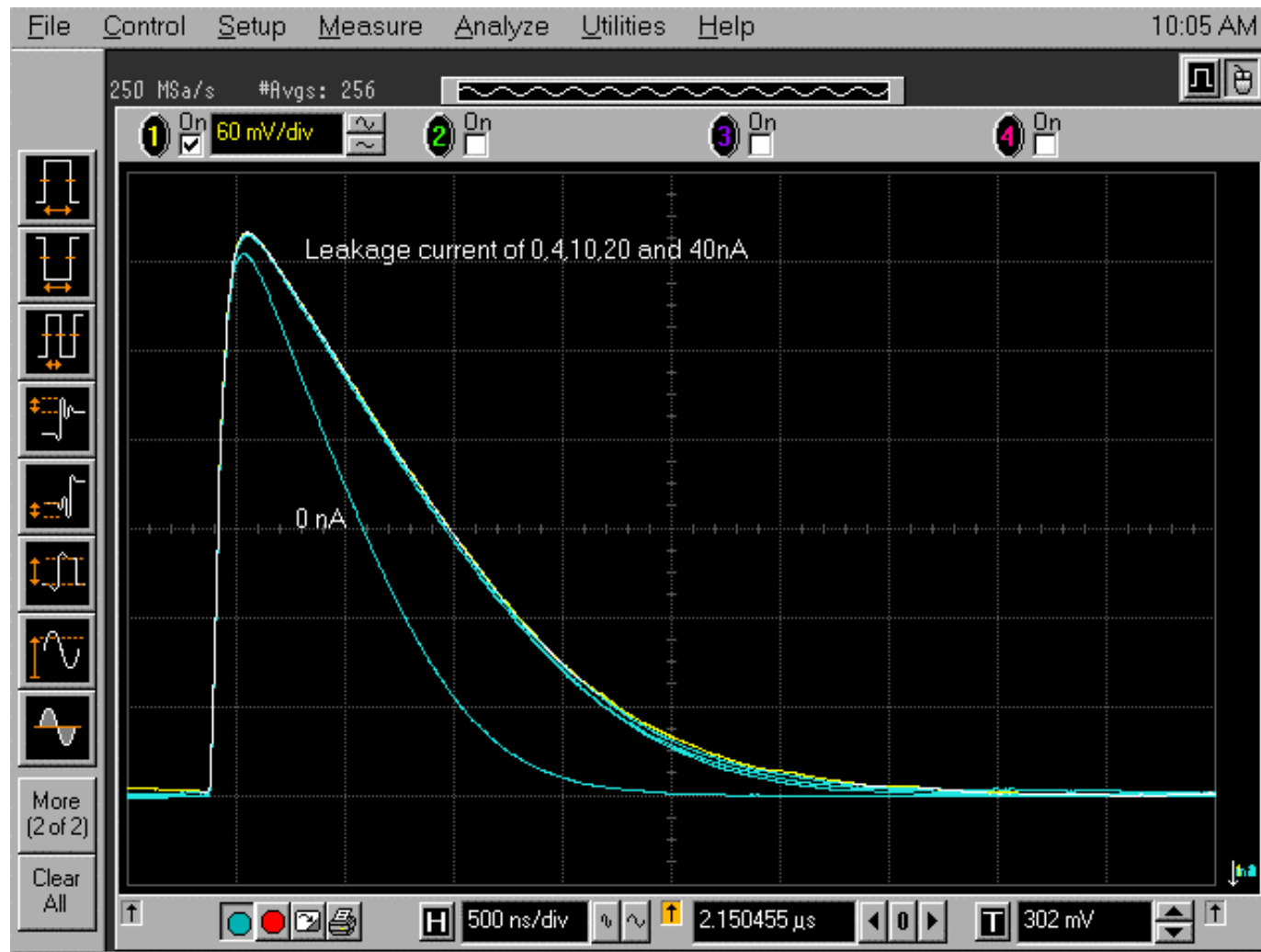

After the first nA no change in the response is observed !

Leakage current compensation II

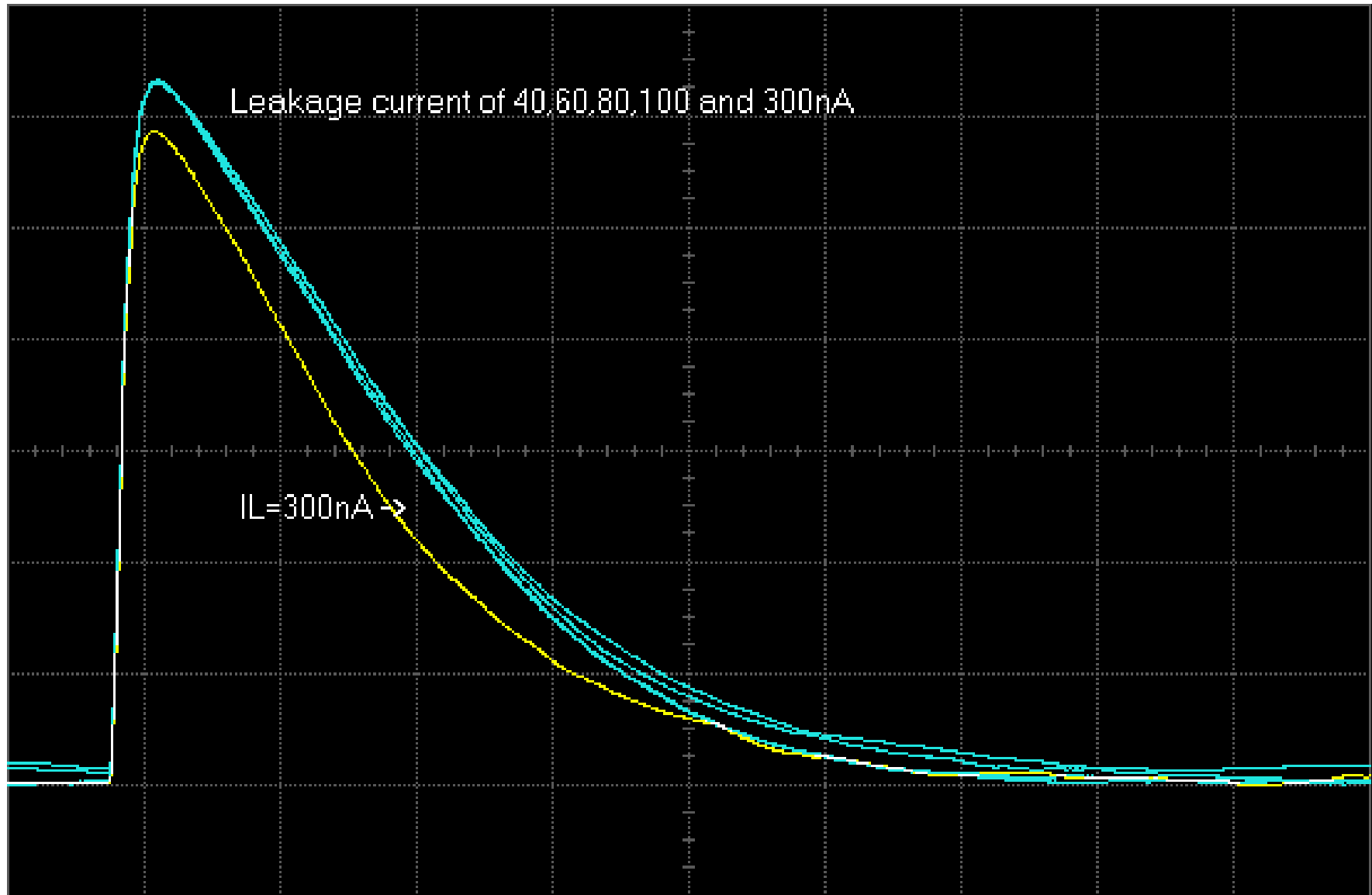

Response to large signals

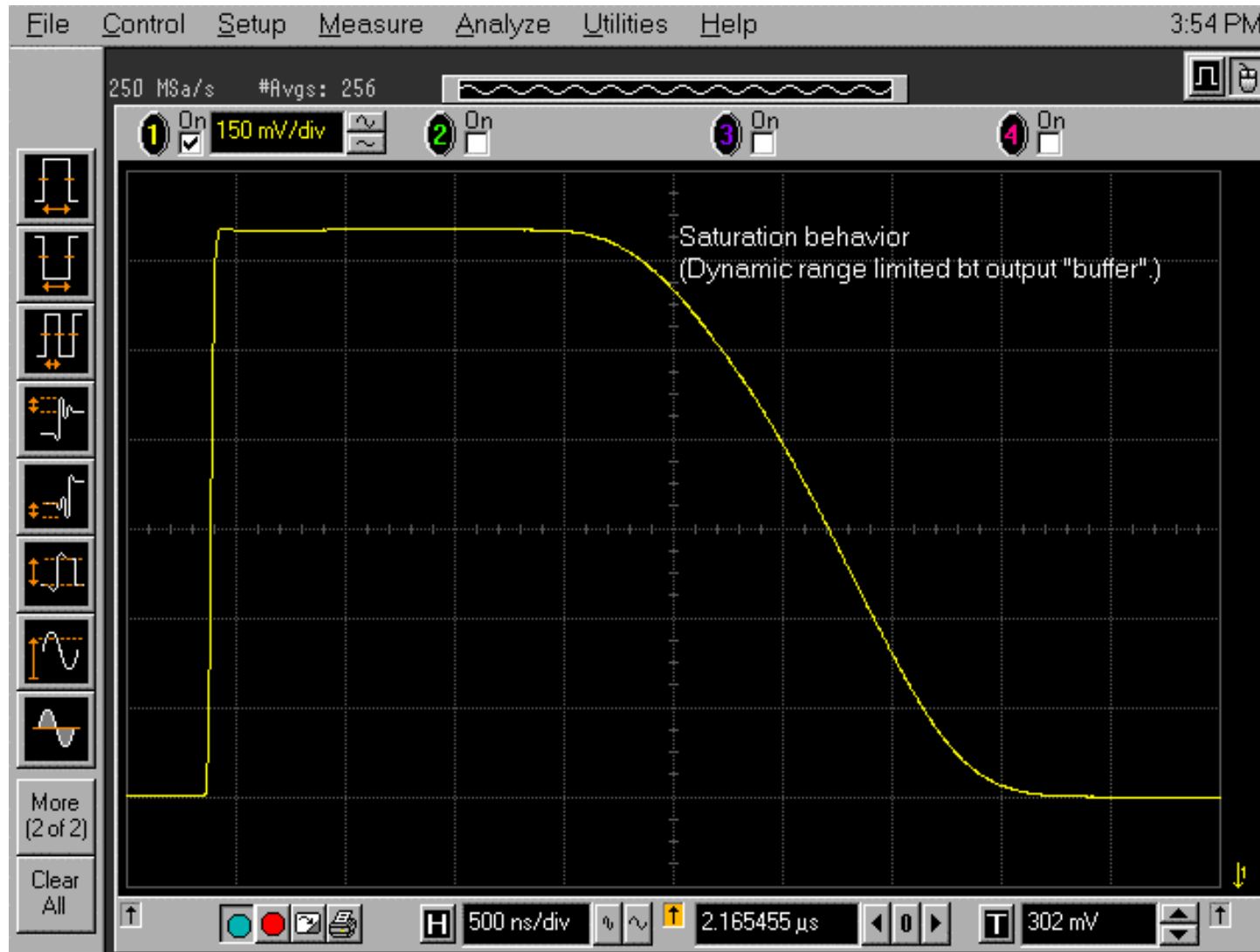

Linearity (small signals)

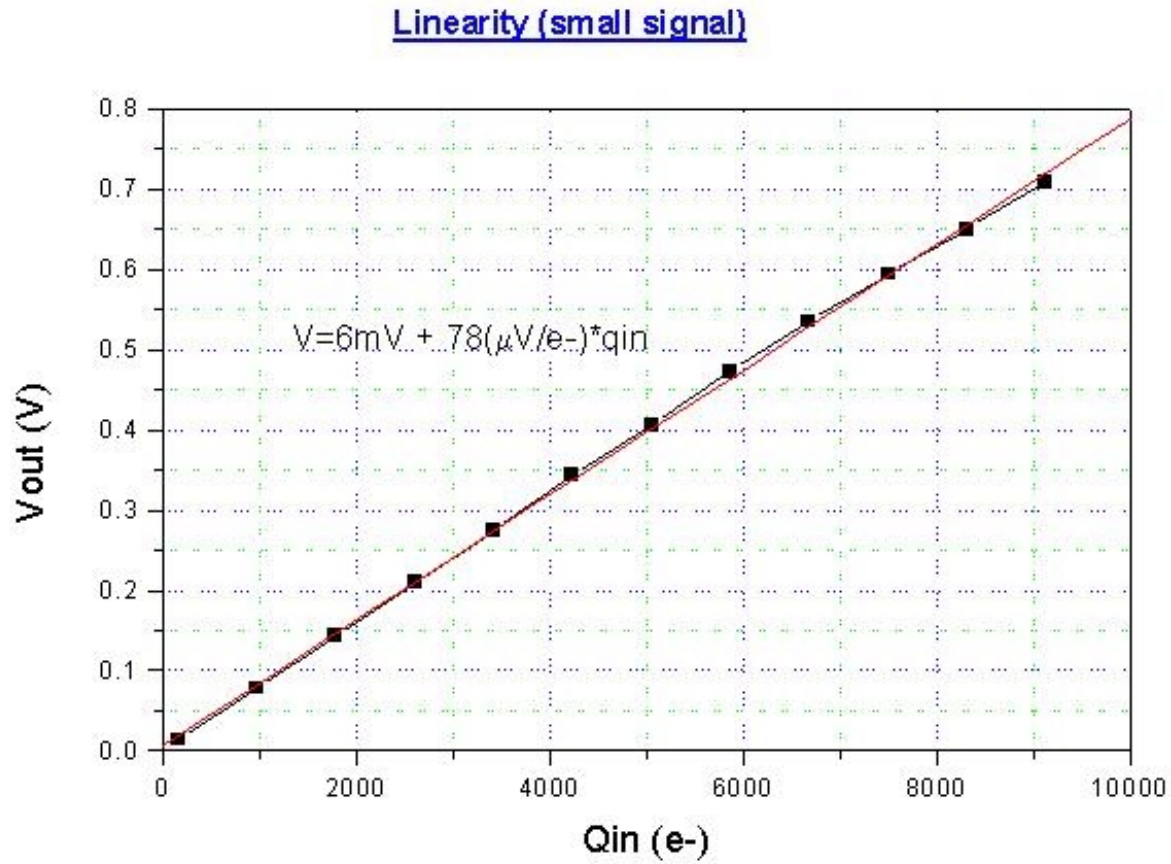

=> Ideal gain = $(1/cf)(Cc2/cf2) = (1/8fF)*4 = 80 \mu\text{V}/e^-$

=> Spice predicted gain = $76 \mu\text{V}/e^-$



Linearity (larger signals)

Linearity (4 channels from 4 # chips)

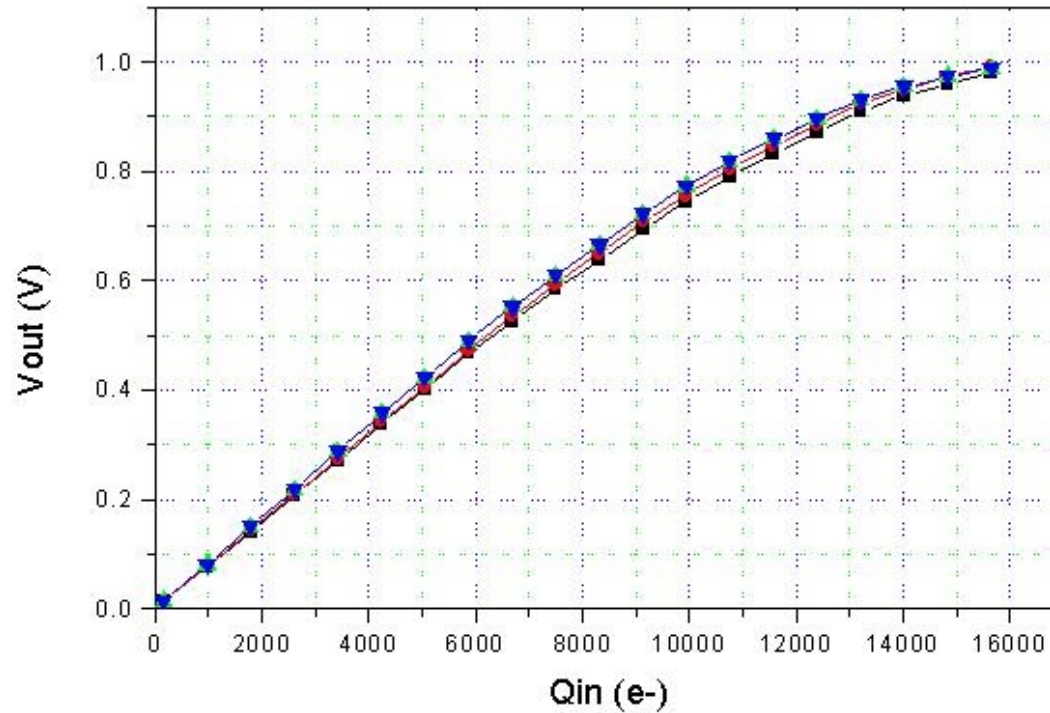

Threshold control and matching

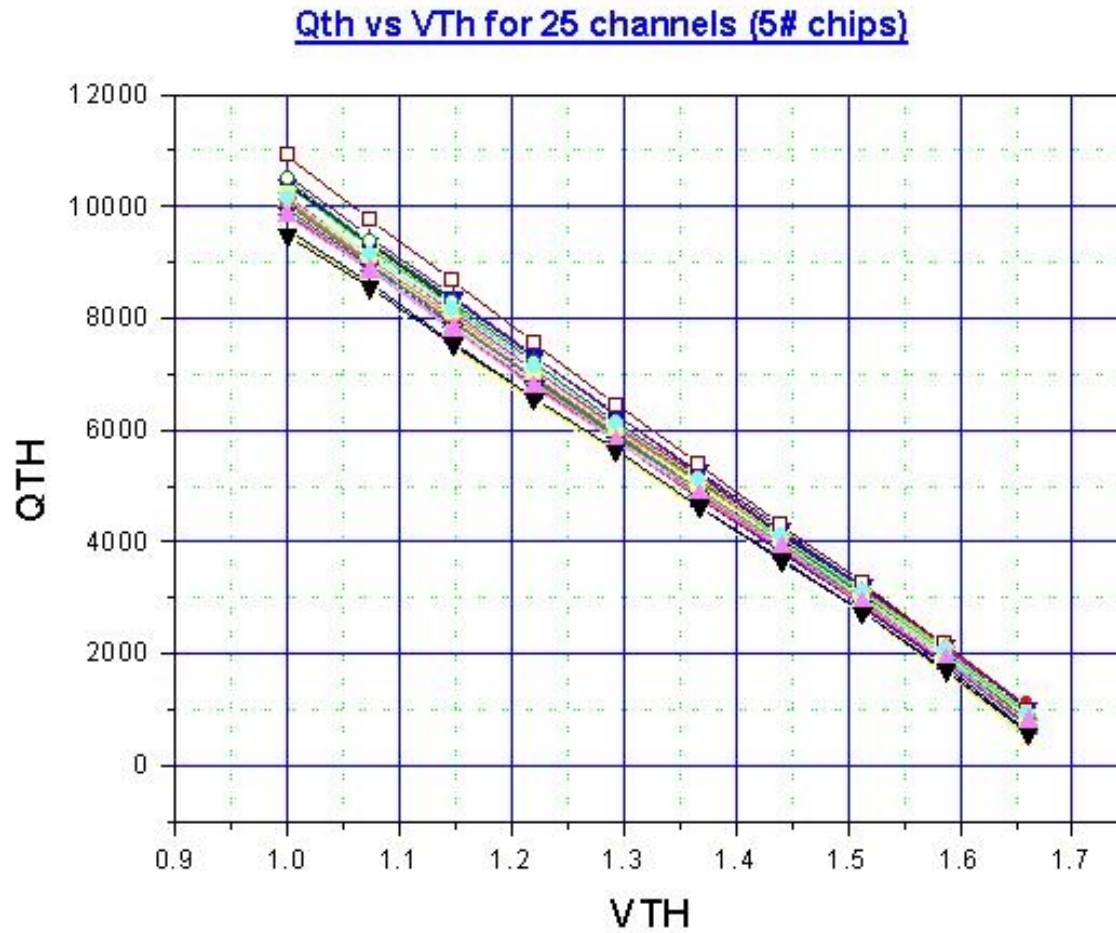

Threshold control and matching II

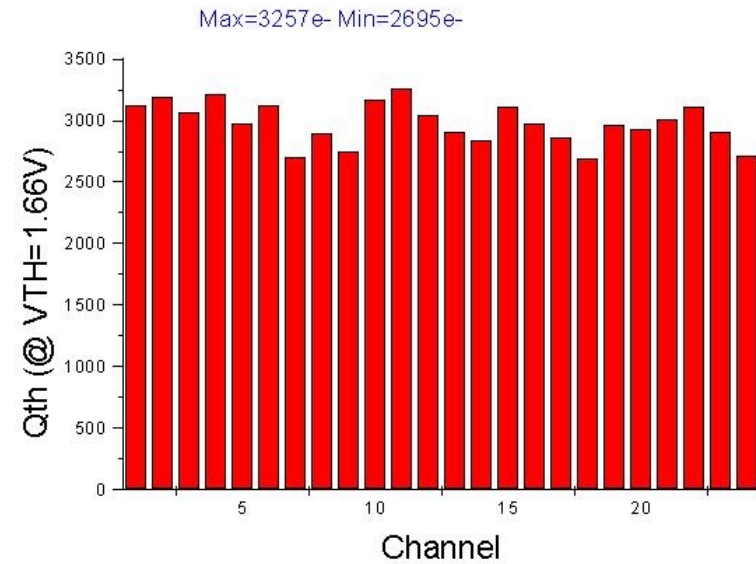
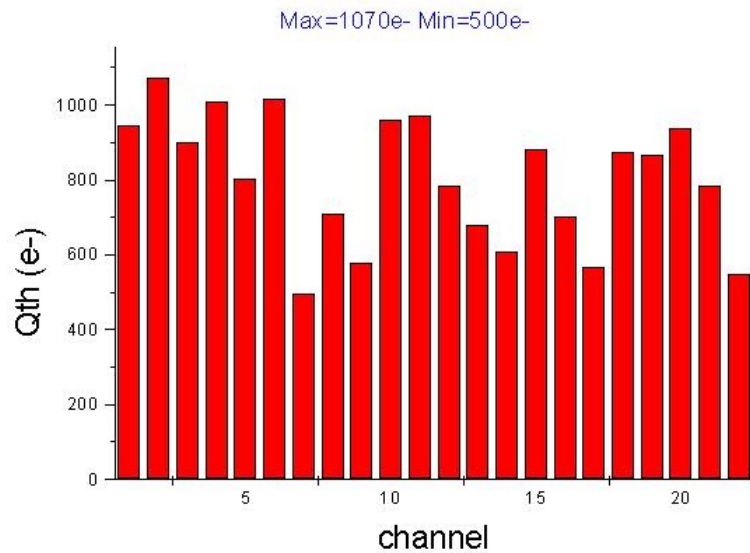

=> 25 channels from 5 different boards.



Noise (measured from efficiency curves)

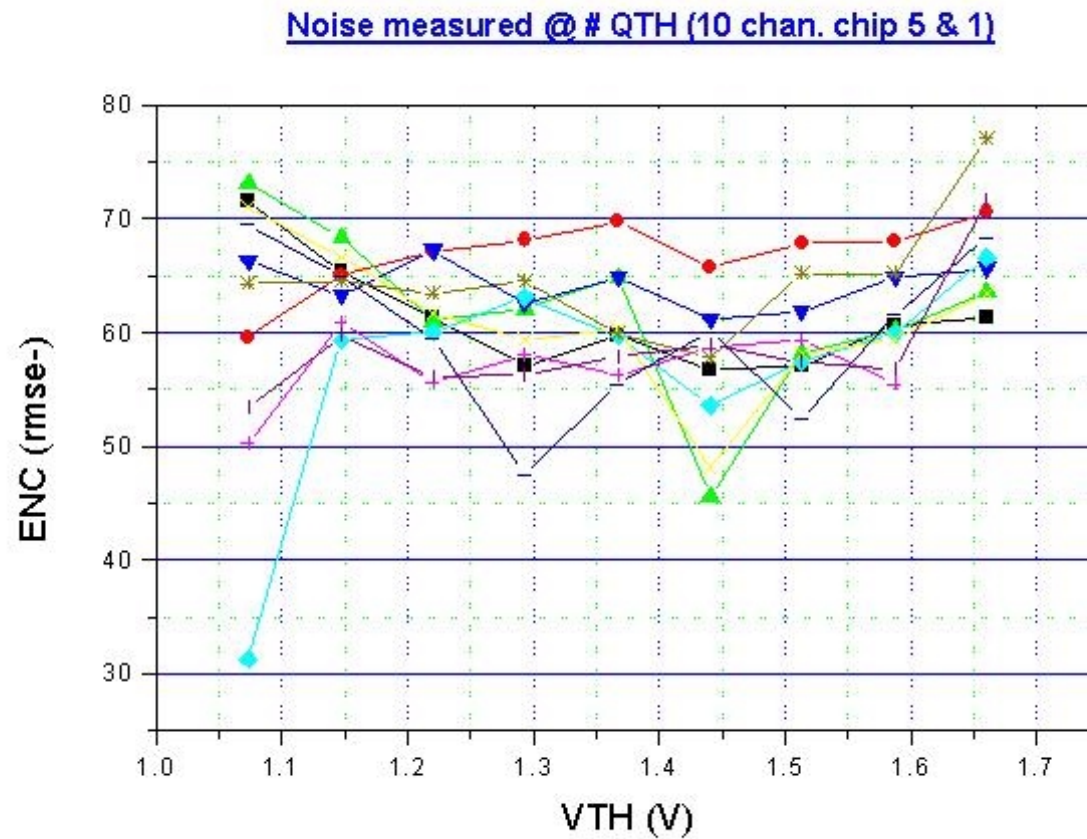

PreFPIX2_T

PreFPIX2_T is 2X160 pixel array. Each pixel cell contains all the functions needed for the BTEV experiment: kill and Inject logic, 3bit FADC, hit buffering, fast sparse RO.

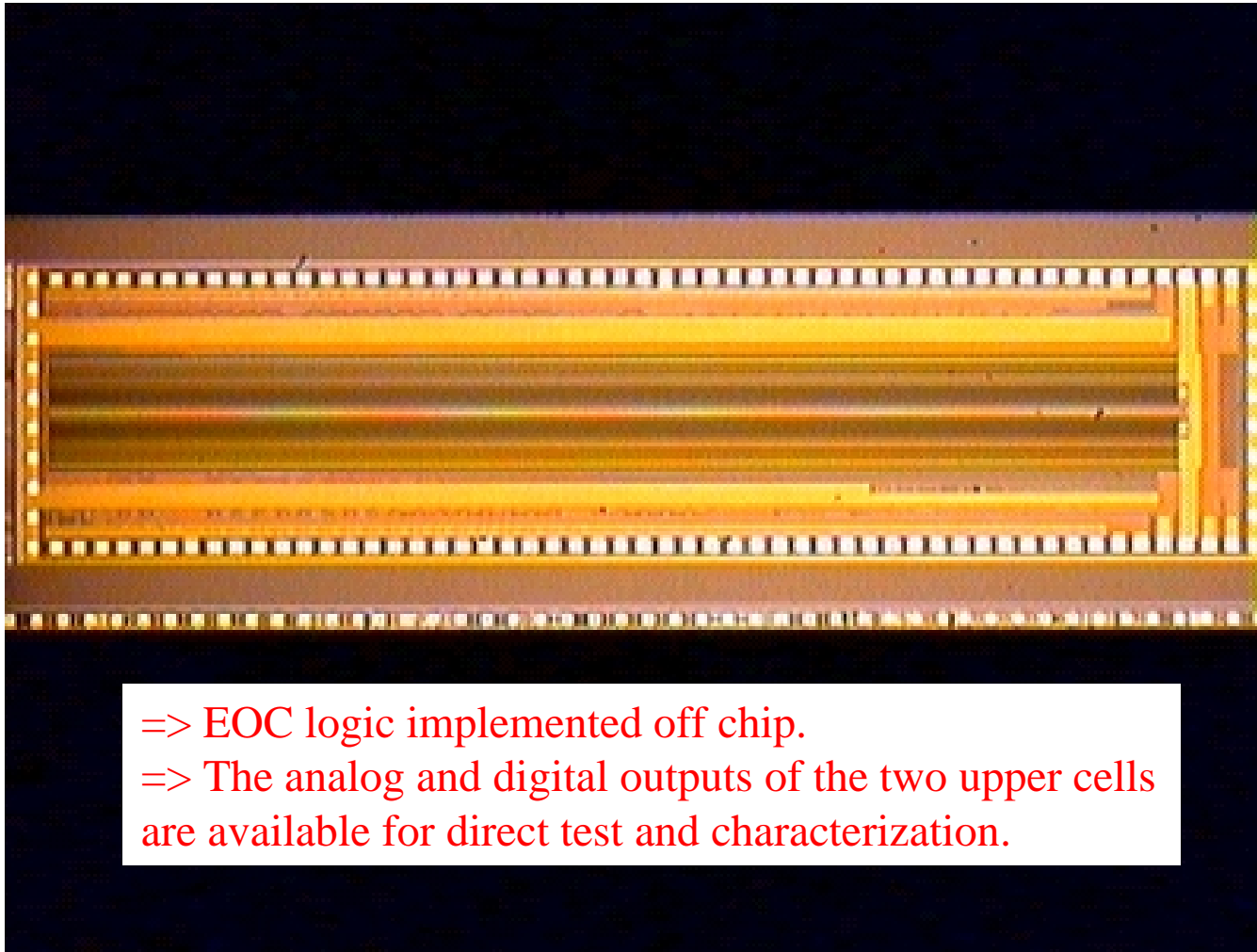

=> EOC logic implemented off chip.
=> The analog and digital outputs of the two upper cells are available for direct test and characterization.

Top cell buffered outputs

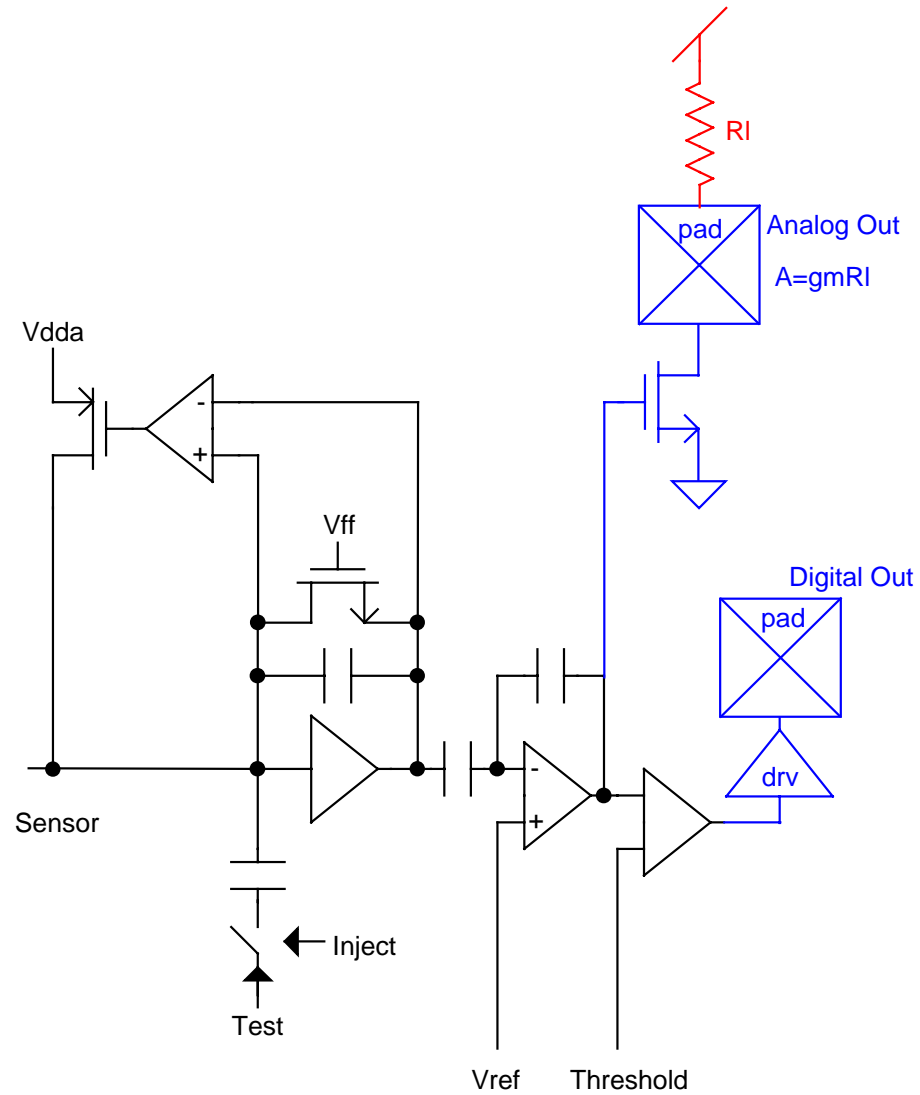

preFPIX2_T front-end

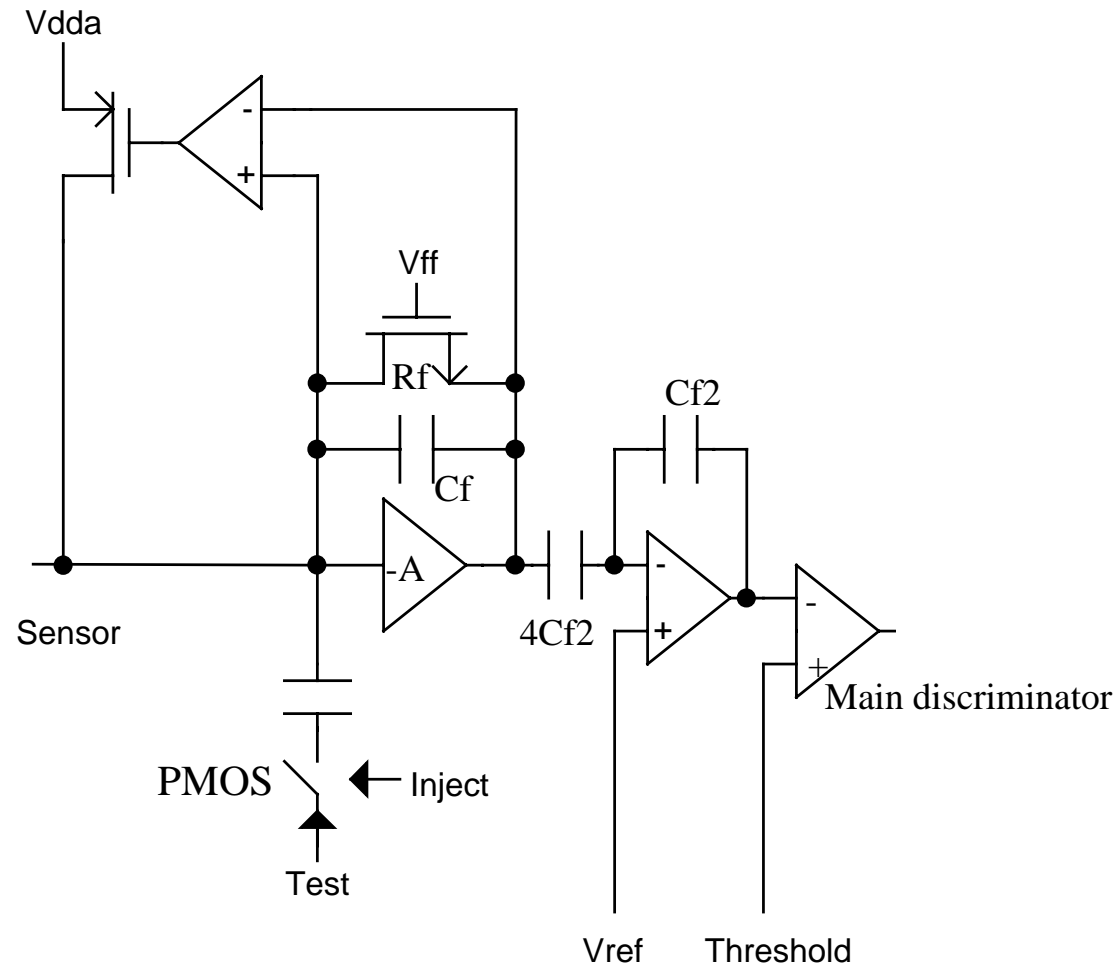

Same FE as preFPIX2 except that the injection transistor is a PMOS and the injection cap is realized with m1/m2 sandwich (2.6fF) instead of m1/poly (4fF). 2nd stage feedback “resistor” not shown.

preFPIX2_T pixel cell

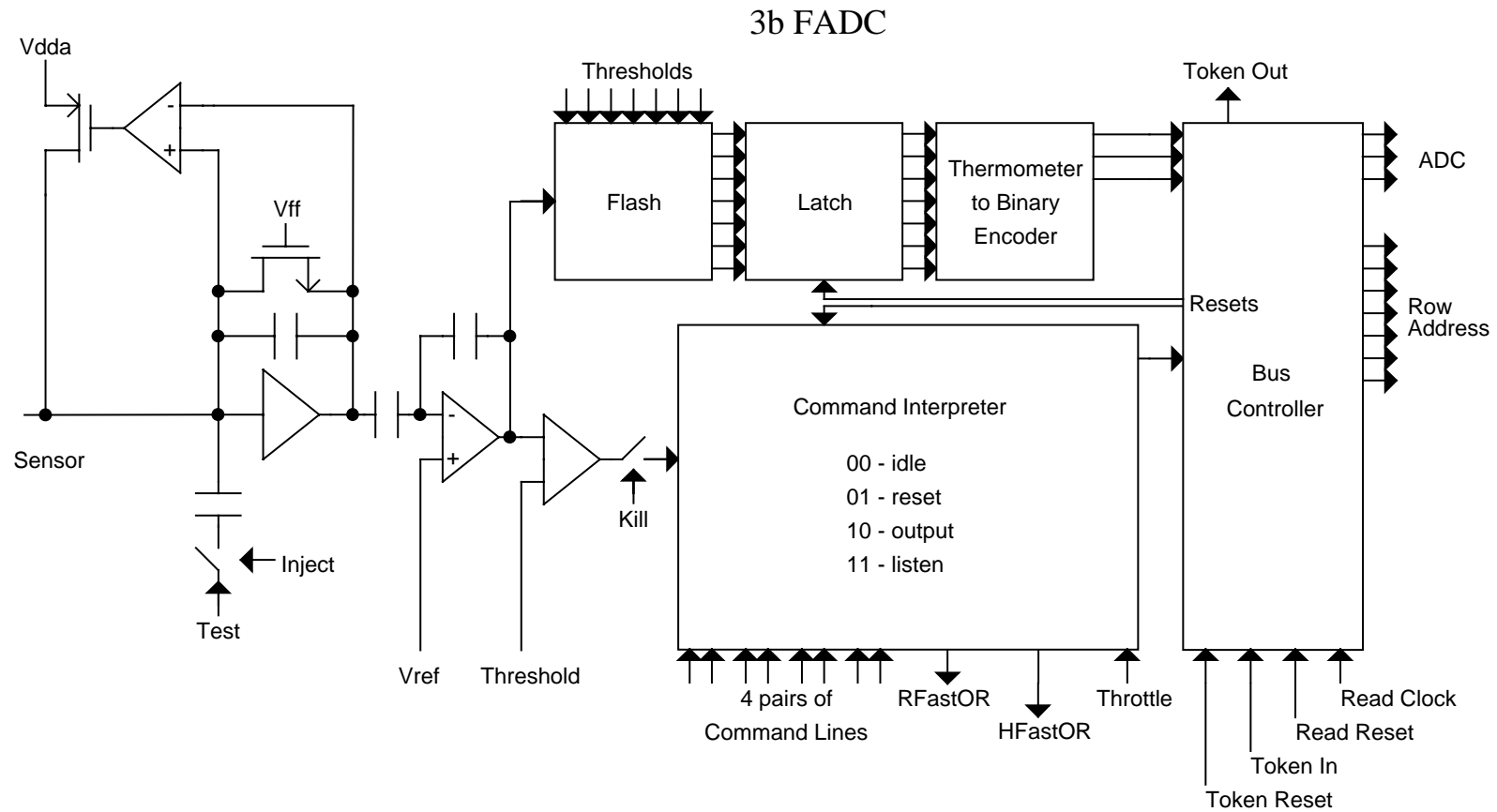

PreFPIX2_T: pulse shapes



Irradiation of the PreFPIX2_T

- We have irradiated several test structures from two 0.25 μ processes, from TSMC and a domestic vendor.
- Besides the individual devices we have irradiated also the prefPIX2 and preFPIX2_T pixel circuits
- The irradiation took place at the Co⁶⁰ irradiation facility of the Argonne National Lab.
- A complete report on the results is still under preparation.
- Partial and VERY preliminary results from the test of the preFPIX2_T will be presented today.

- Dosimetry accurate to 20%.
- No filter for low energy particles was used.
- All the results shown are after 1 to 7 days of annealing at room temperature.
- In all subsequent slides rad should read rad(SiO₂)



General effects after 33 Mrad

- Chip fully functional
- No degradation in speed (as inferred from the kill/inject shift register operation).
- Less than 10% change in “analog” power. Power was less after irradiation. Understandable from circuit point of view and is due to small V_T change in the PMOS (<50 mV).



Total dose effects on front-end



Total dose effects on front-end

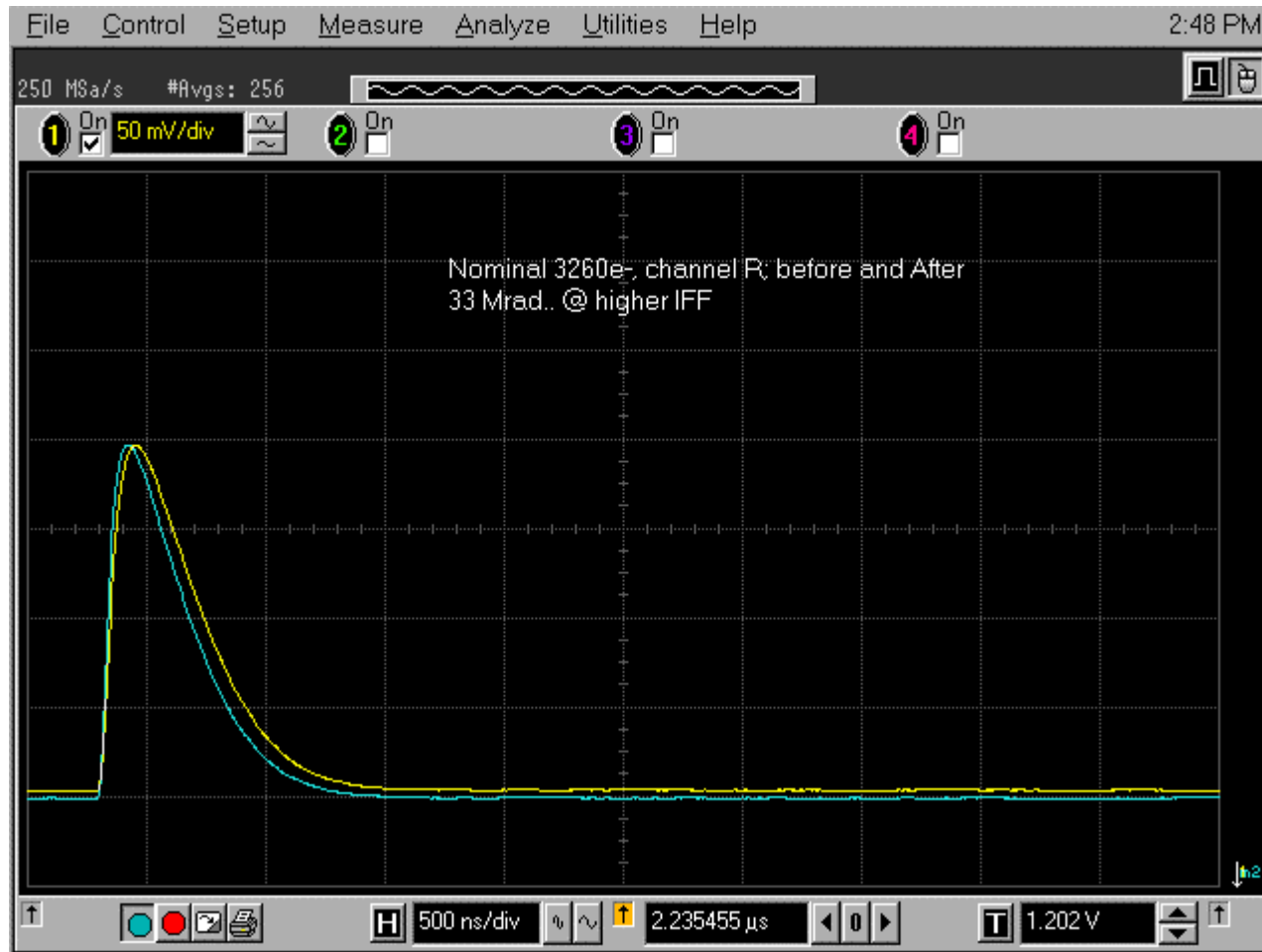

Total dose effects on front-end

Before irradiation

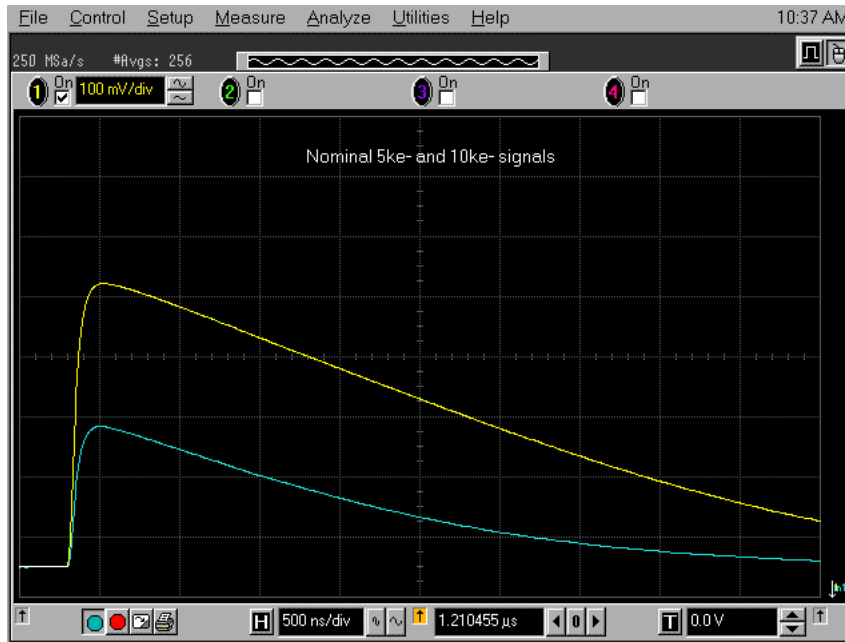

After 33 Mrad

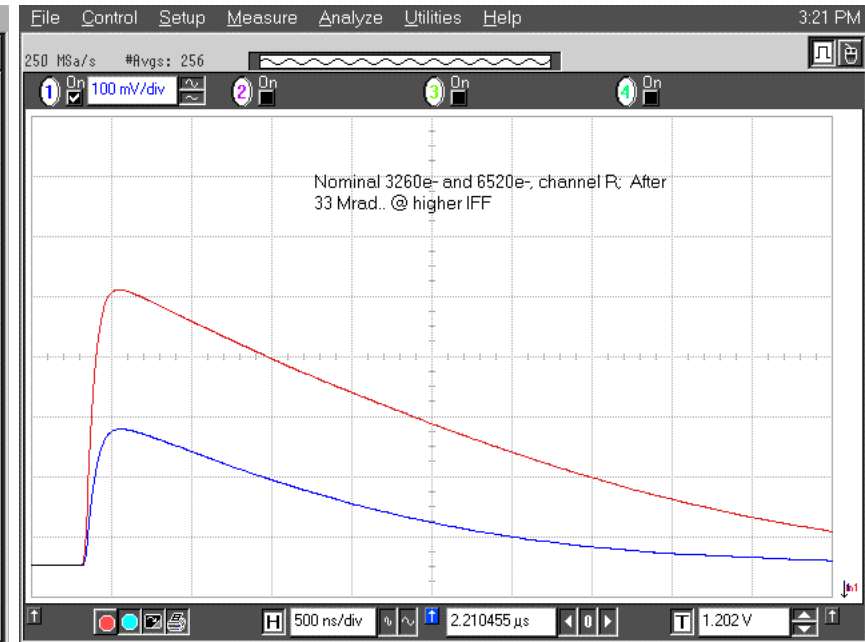

- => 3 mV DC offset shift (due mainly to output buffer)**
- => < 4% Rise time difference**
- => < 5% change in fall time.**

Linearity before and after 33 Mrad

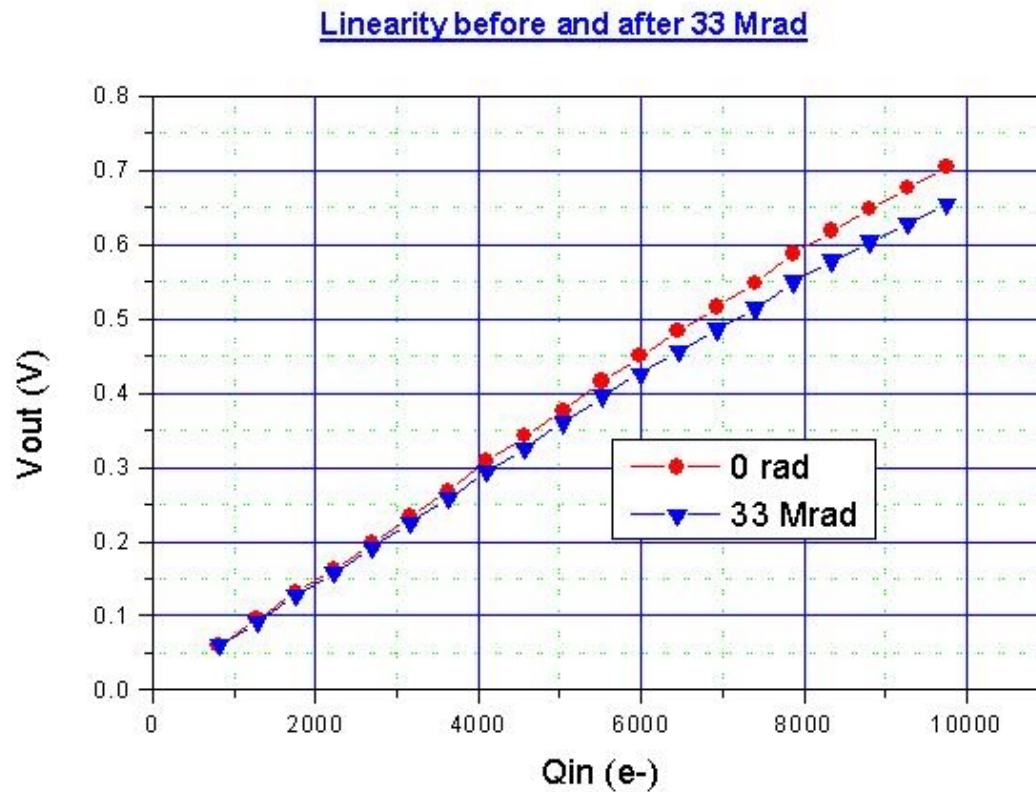

=> 7 % max gain error. Believed to be due to output buffer only.

Rise and fall time before and after 33 Mrad

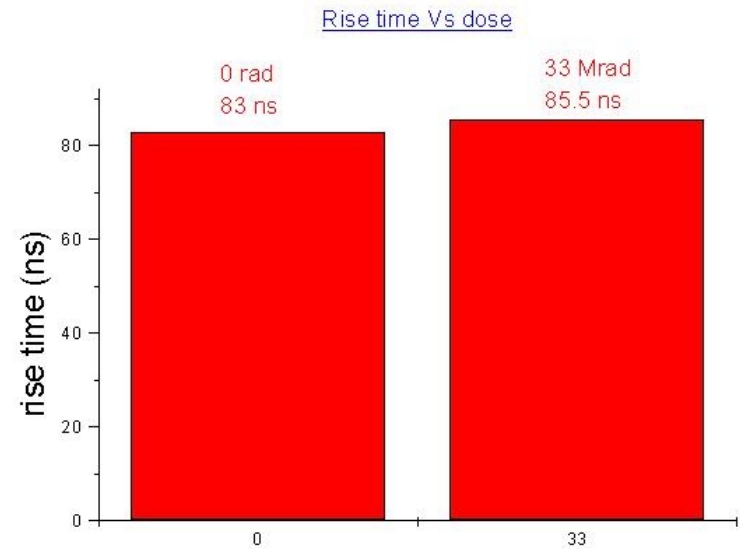
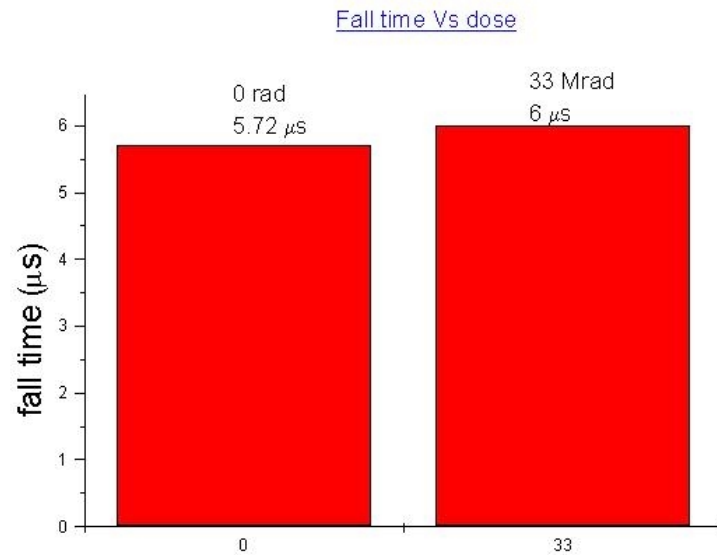

=> Changes are minimal and may disappear after annealing.



Noise and threshold distributions

NOISE DISTRIBUTION vs DOSE

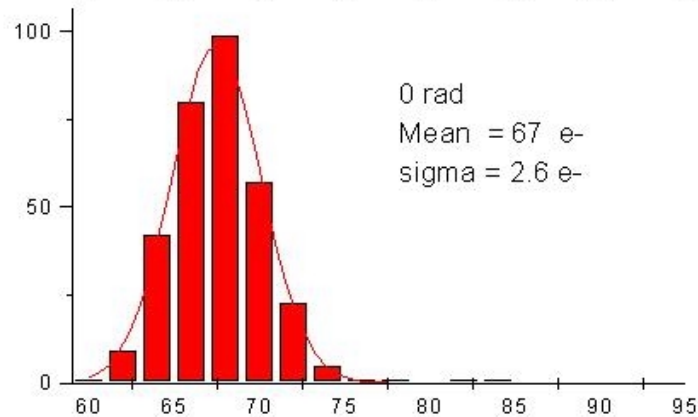
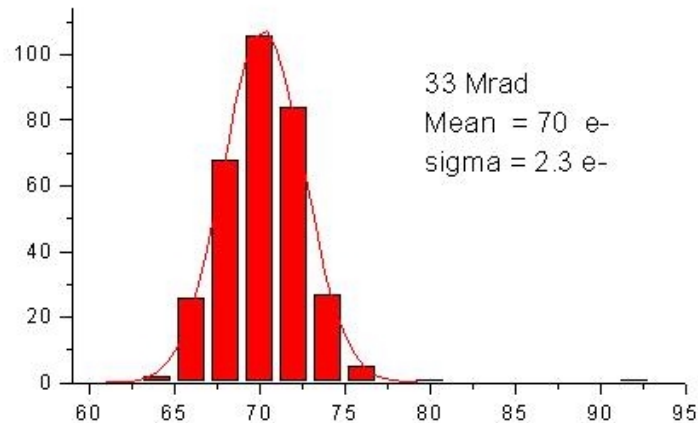

THRESHOLD DISTRIBUTION vs DOSE

@ minimum threshold

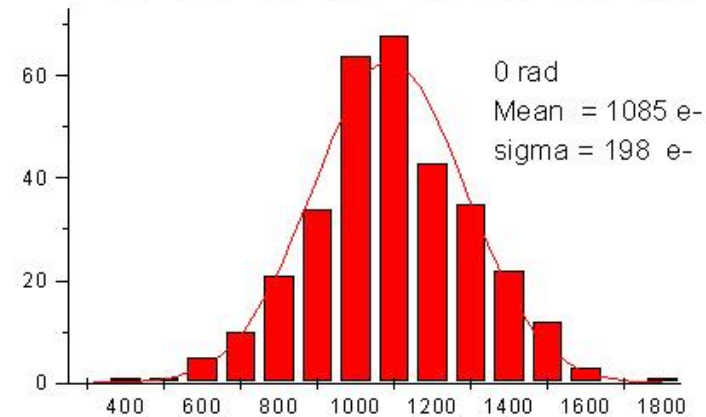
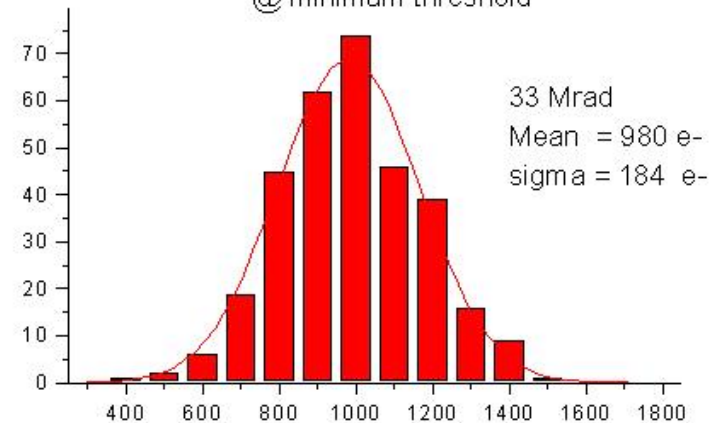

- => Practically no change in noise and threshold dispersion.
- => 200 e- change in the threshold voltage.

Effects at higher threshold

THRESHOLD DISTRIBUTION vs DOSE

@ 3400e- threshold

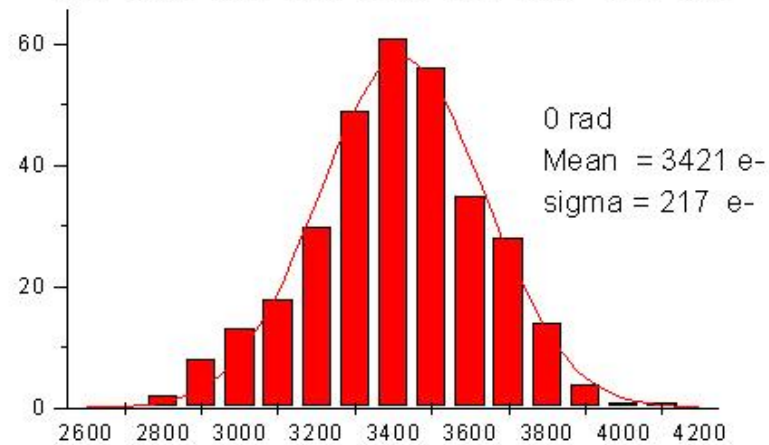
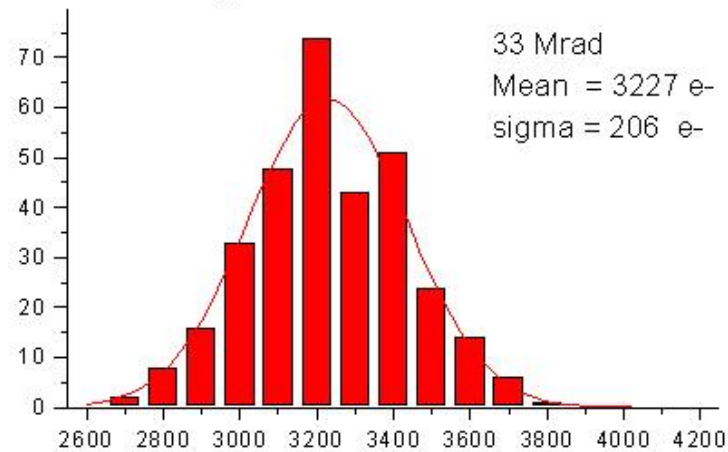

Readout typical output

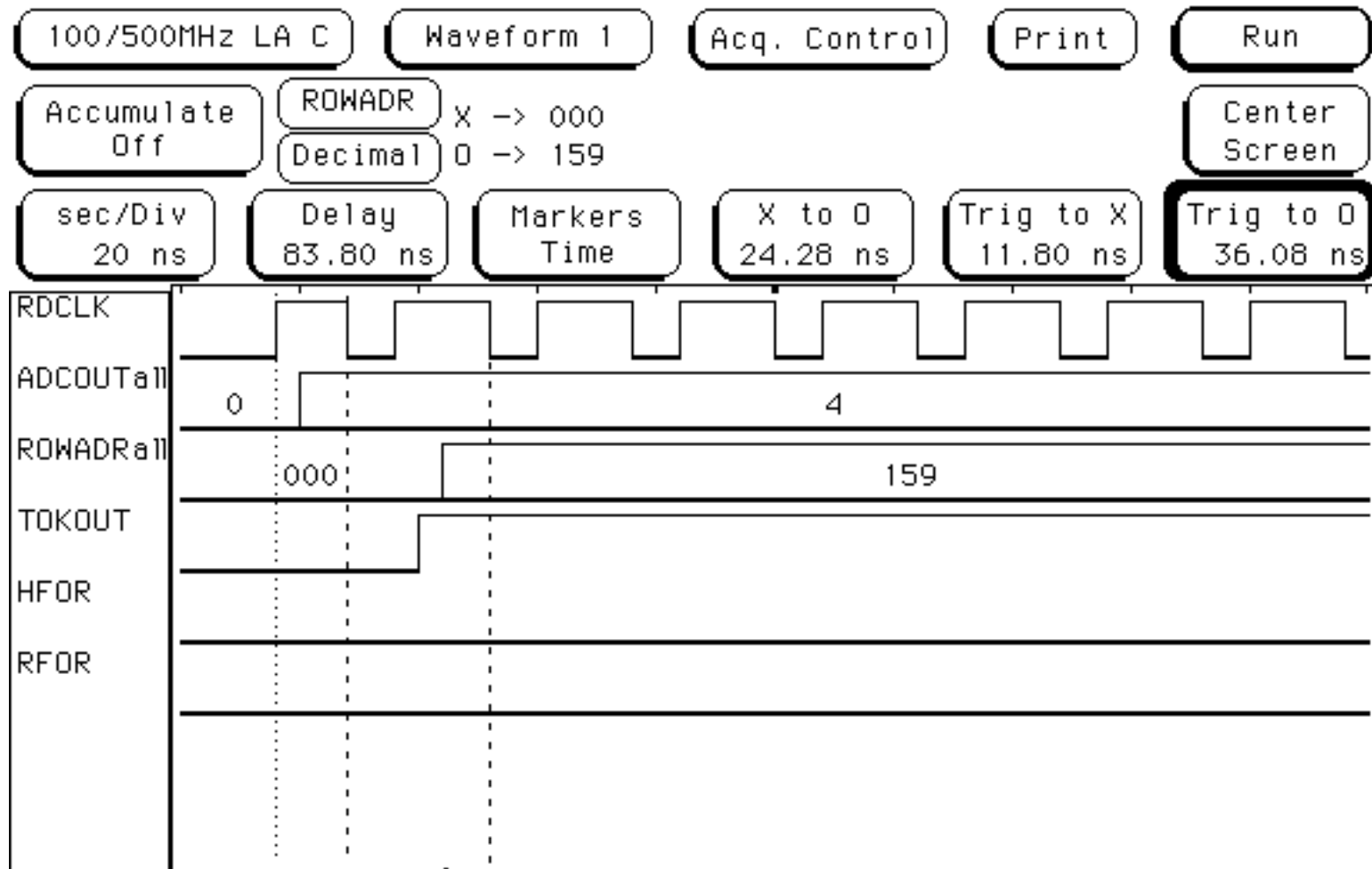

Readout Max speed

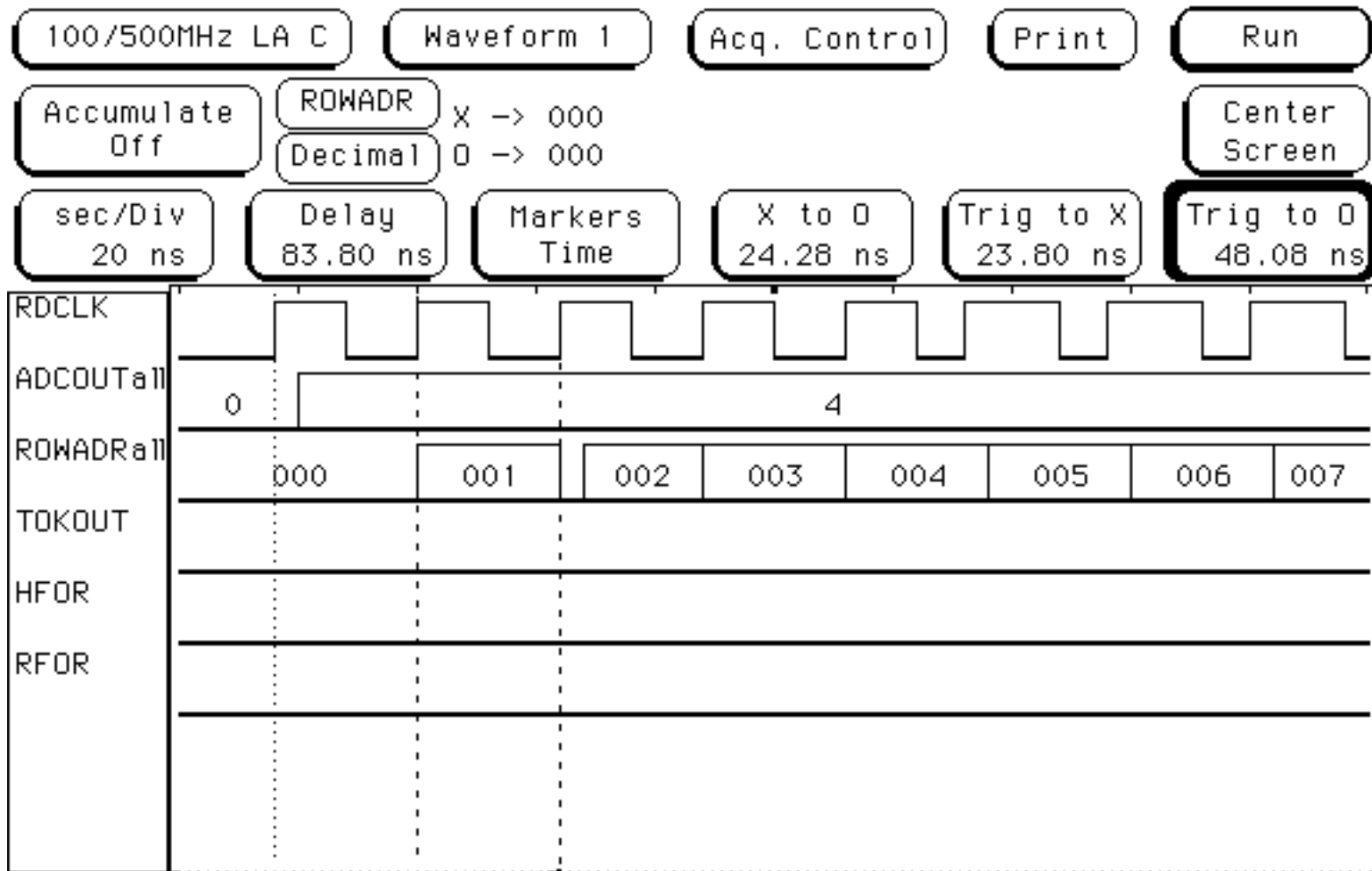

Conclusions

- We successfully migrated our design from 0.5 μ process to 0.25 μ using radiation tolerant techniques.
- The design can be submitted to two different vendors.
- Chip performed as expected before and after 33 Mrad.
- We are still working on the radiation results.
- DSM is the way to go for radiation hardness (if you can).



Acknowledgements

- William Wester co-organizer of the irradiation “week”.
- Tory Steed and Al. Al Svirmickas from ANL for their precious help.
- Al Deyer and Kelly Knickerbocker for preparing the boards and the 100’s of feet of cable.
- Ray Yarema for his advice and encouragements.

