



Results on 0.7% X0 thick Pixel Modules for the ATLAS Detector.

INFN Genova:

*R.Beccherle, G.Darbo, G.Gagliardi, C.Gemme, P.Netchaeva,
P.Oppizzi, L.Rossi, E.Ruscino, F.Vernocchi*

Lawrence Berkeley National Laboratory (LBNL):

K.Einsweiler, M.Gilchriese, J.Richardson, G.Zizka

on behalf of ATLAS Pixel collaboration

ATLAS Pixel Modules.

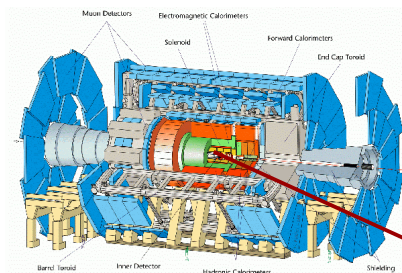

ATLAS

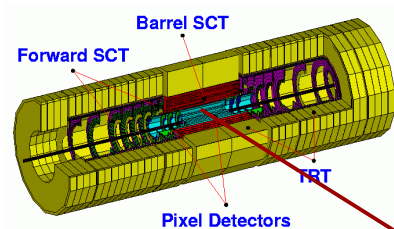

Inner detector

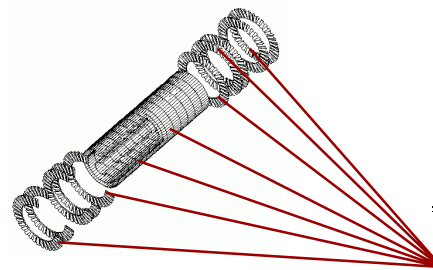

Pixel detector

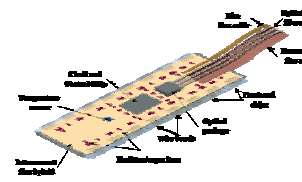

Modules

~2200 Modules

- *sensitive area 16.4 mm X 60.8 mm*
- *16 FE chips with 18 X 160 pixels*
- *pixel size 50 μm X 400 μm*

ATLAS Pixel Module Components.

- **Silicon Sensor**
- Kapton **Flex-hybrid** glued to the **Sensor** (talk of F.Huegging)
- 16 **FE chips** bump-bonded to the **Sensor** and wire-bonded to the **Flex-hybrid**
- **Module Control Circuit (MCC)** wire-bonded to the **Flex-hybrid**
- **Passive components** including termination resistors, decoupling capacitors and temperature sensor
- **Pigtail** - bus lines routing signals to/from MCC

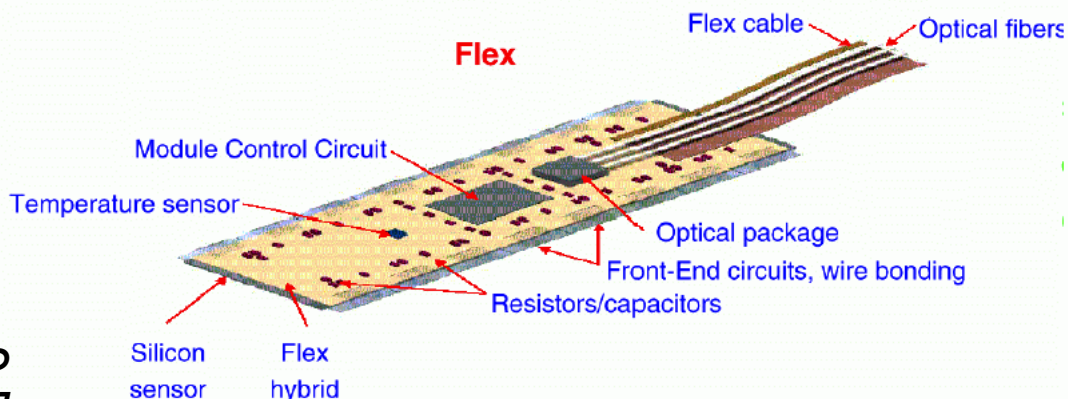

First prototypes did not have optical connections or Flex power connection and have been mounted on PC boards for testing.

Material in Produced Thinned Modules.

<i>Item</i>	<i>%X0</i>
<i>Sensor (280 μm thick)</i>	<i>0.34</i>
<i>Front-end Electronics (150 μm thick)</i>	<i>0.21</i>
<i>MCC (560 μm thick)</i>	<i>0.04</i>
<i>Kapton flex (50 μm thick + coverlay)</i>	<i>0.05</i>
<i>Passive components on kapton (R,C)</i>	<i>0.03</i>
<i>Wirebond potting</i>	<i>0.03</i>
<i>Wirebonds, bump bonds and glue (kapton on sensor, MCC on flex) are individually negligible and they sum up to</i>	<i>~0.01</i>
<i>Total</i>	<i>0.70</i>

- *The normalization has been done to the module's sensitive area (16.4 mm x 60.8 mm)*
- *The total radiation length value meets Pixel Detector Technical Design Report specifications.*

Module Production: Bump-bonding and thinning.



Bump deposition on wafers (Sensor & electronics)

Thinning of FE wafers and cutting

Flip-chipping of 16 FE chips to Silicon Sensor

X-rays test of assembly FE chips + Sensor (bare Module)

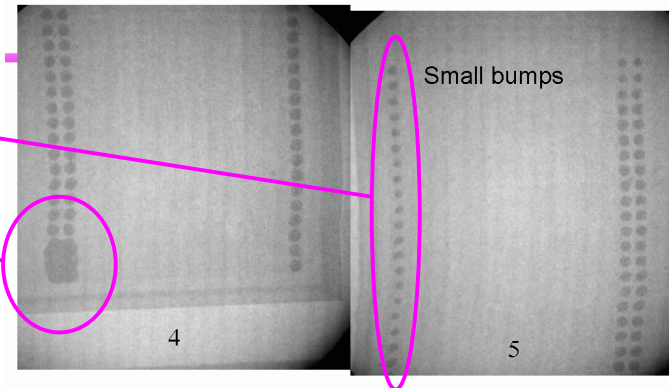
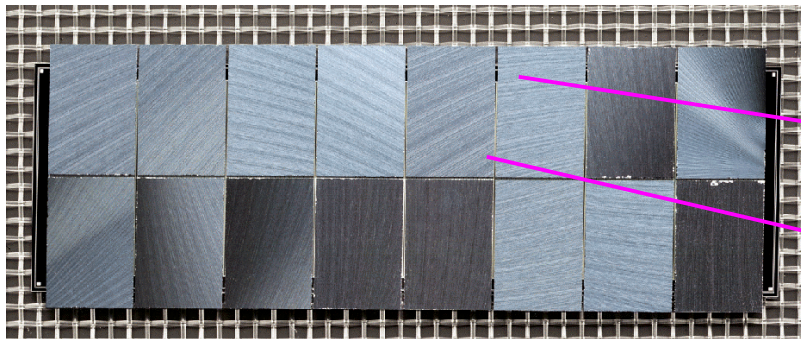

*X-rays test -
2 μ m resolution radiography:
some bump problems are visible*

Module Production: Flex-hybrid.

Test of Flex-hybrid itself: flying probe test

Mounting of passive components on Flex-hybrid and test

Mounting and wire-bonding of MCC to Flex-hybrid

*Flex-hybrid test with mounted components:
voltages, read/write MCC registers*

(see the talk of P.Skubic)

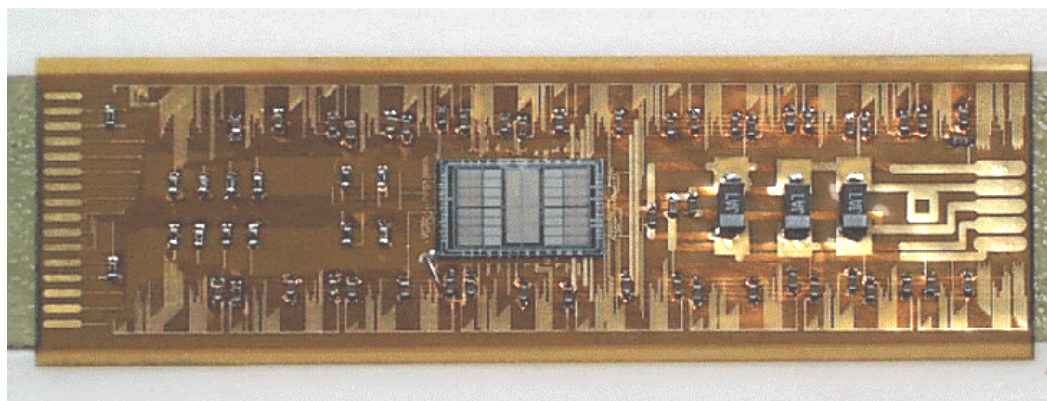

Gluing Flex-hybrid to the bare Module

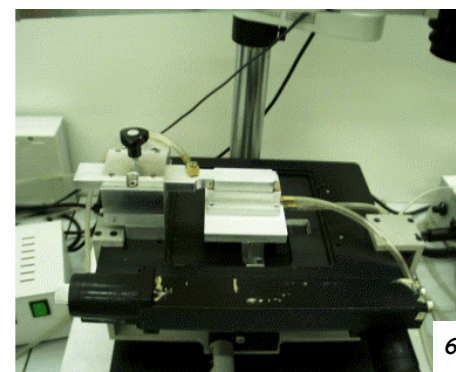
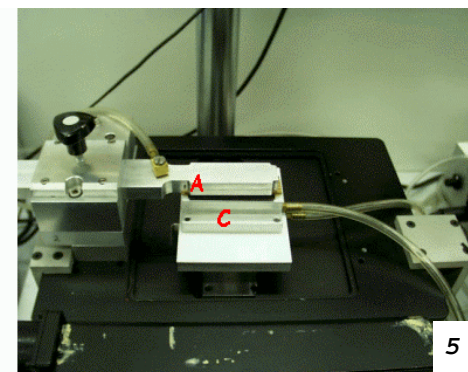
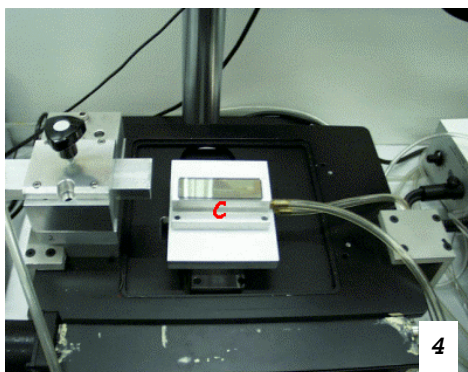
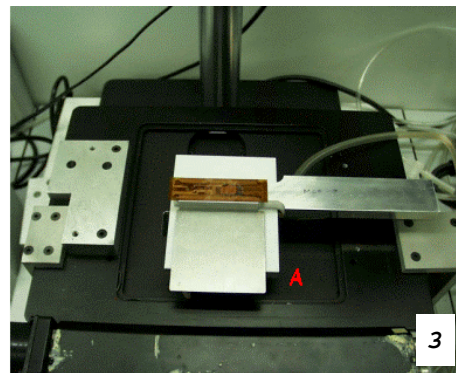
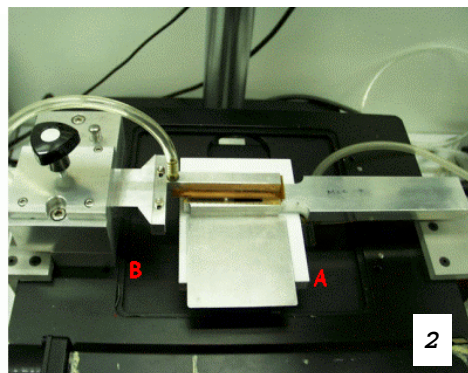
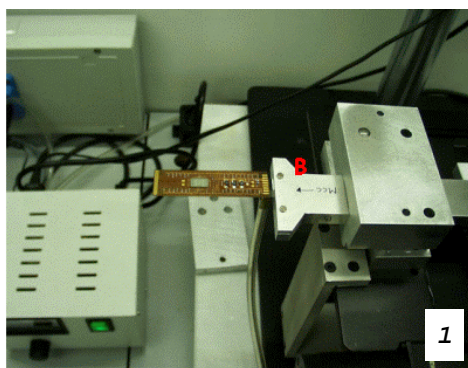

Flex-hybrid is being fixed on the special profile plate (3) not to damage wire-bonded MCC and components. Glue (EPOTEK 353) is being deposited corresponding to FE pads and under MCC. Optical alignment between Sensor and Flex-hybrid is being performed (5). Glue polymerization with infrared lamp (40 C, ~12 hours).

Gluing to Support Card and Thermocamera test

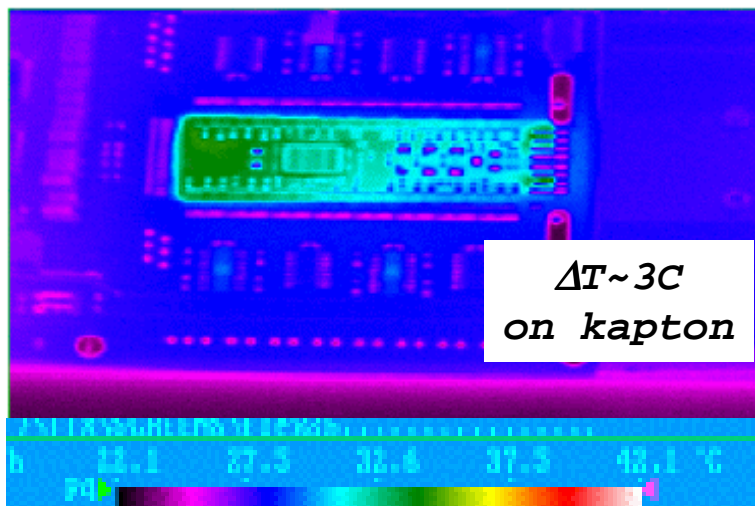
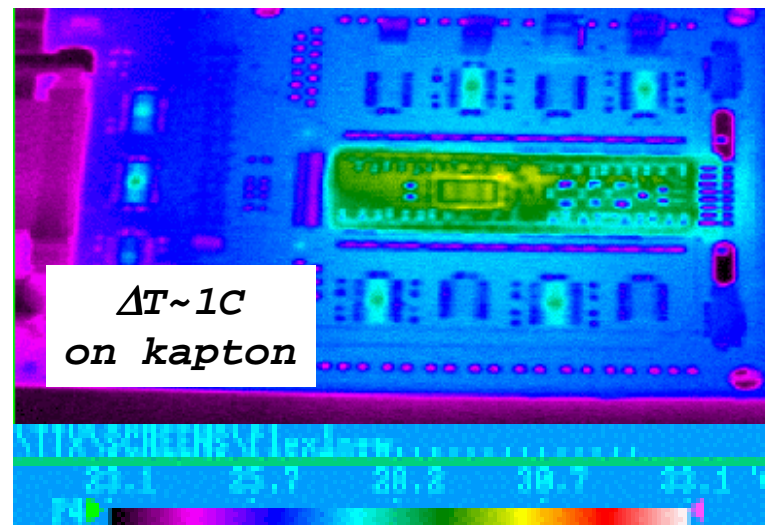
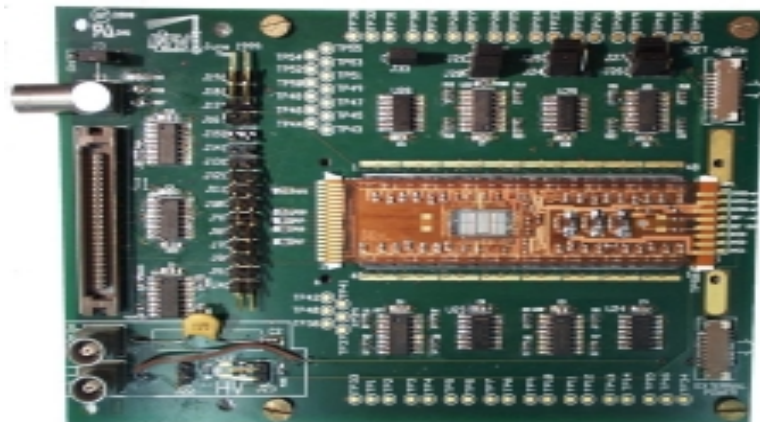

Module is being glued to the Support Card with silicon glue (Dow Corning, 20 C, 24 hours).

Thermal contact and thermal uniformity are being tested with thermocamera on module in operation.

Module Production and Tests (continued).

Wire-bonding of FE chips to Flex-hybrid => **Module**
 Test of Module (digital, analog, with radioactive source)

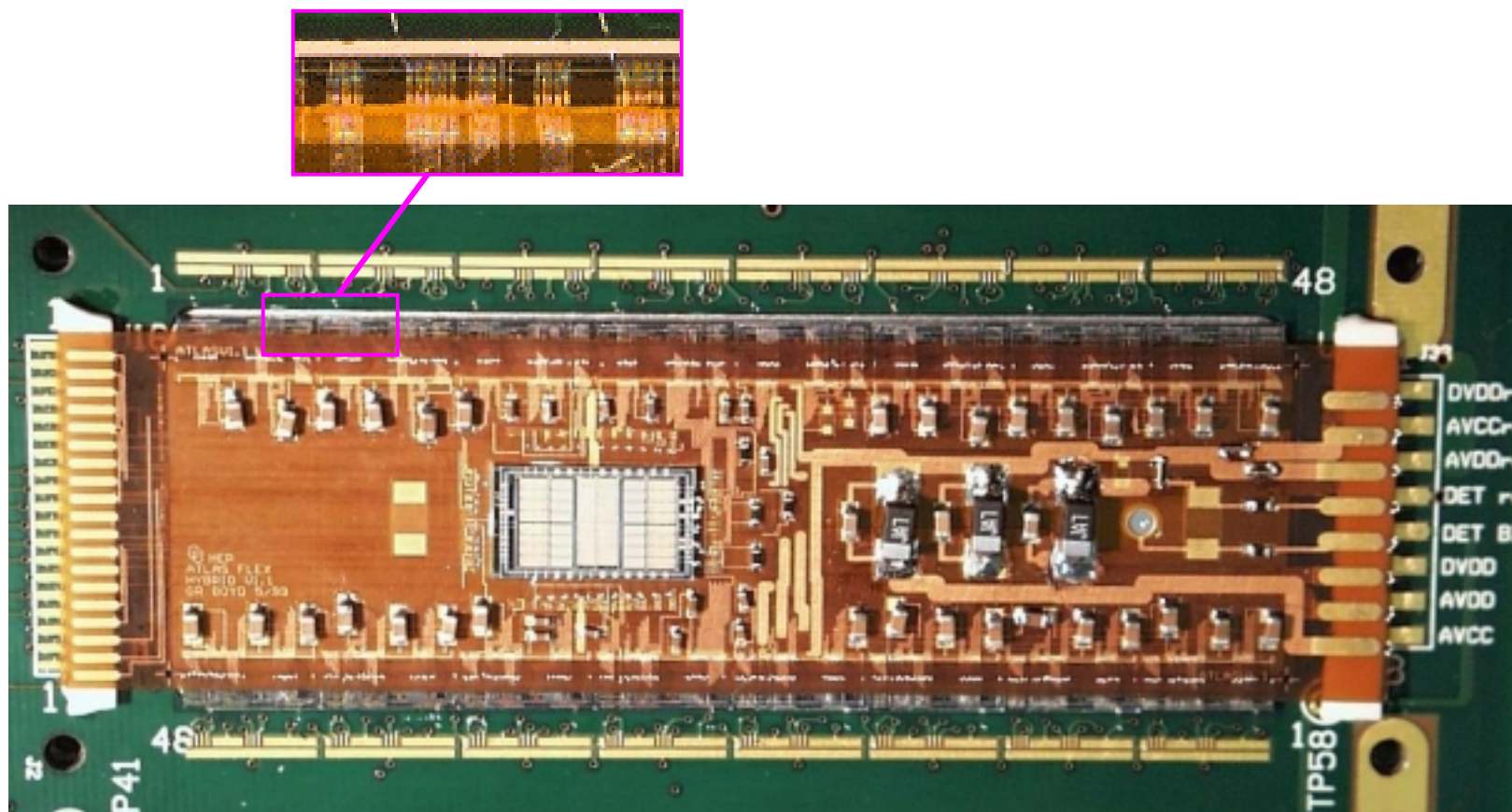

Module Tests verifying every pixel cell

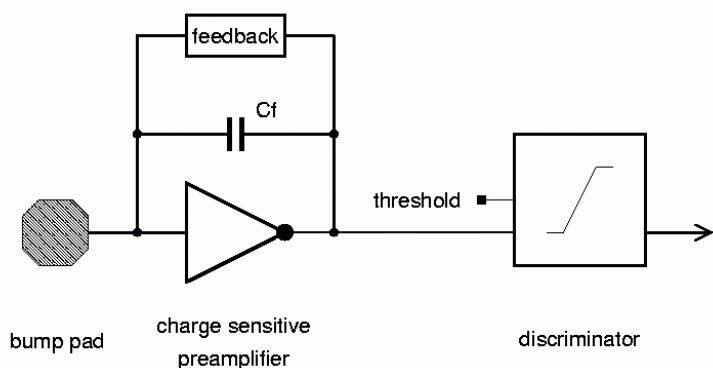

Quality factors for Module:

- ≡ **threshold and threshold dispersion**
- ≡ **noise**
- ≡ **number of dead channels**
- ≡ **stability**

Digital test (does a pixel cell work from discriminator to readout?)

Analog test and thresholds tuning for every FE chip (does a pixel cell work from amplifier to readout and what are the characteristics - threshold, noise?)

Test with source: ^{109}Cd (22KeV X-rays), ^{241}Am (60KeV γ), ^{90}Sr (β).

Comparison with micro-radiography bump quality data.

Results on Thin Module 1 (LBNL + Boeing) November 1998.



*Electronics had been thinned to 150 μm by GDSI after bumping.
The flip-chipping had been done by Boeing.*

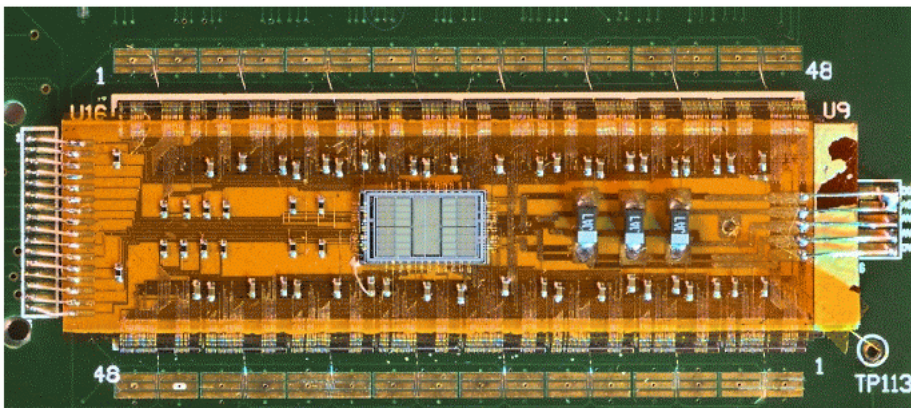

The whole module worked well according to the digital test.

One FE chip (#15) did not respond to analog charge injection.

Some bump-bonding problems, including several chips with regions of merged bumps.

Significant problem with Boeing bump resistance.

Results on Thin Module 1

File : flex_tune Summary Plots

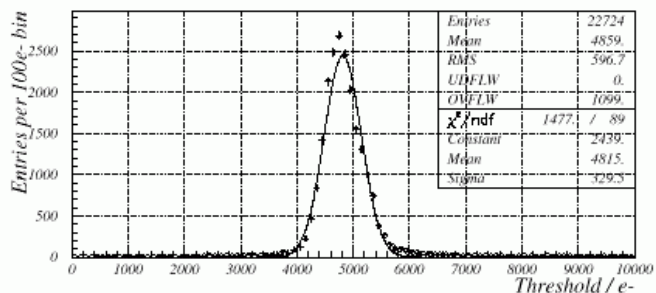

Thresholds were about 4800e.

3 FE chips were very noisy, by switching them off high noise (>500e) tail had disappeared.

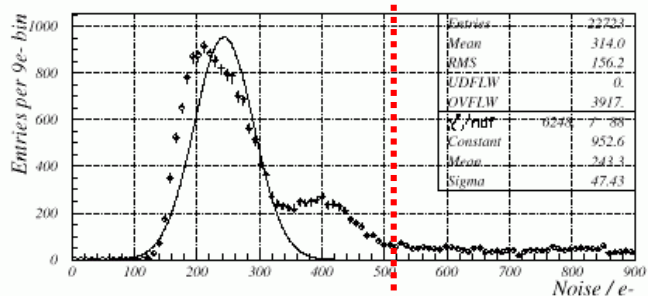

"Good" chips had mean noise value of about 270e.

Boeing stopped bumping for outside customers, this had delayed thin modules production for some time.

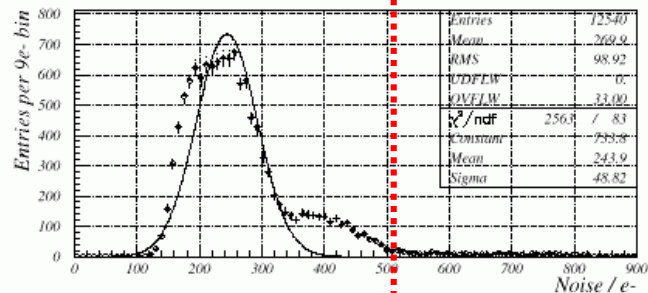

Results on Thin Module 2 (INFN Genova + AMS) April 2000.



- ❁ Thinned electronics FE_B.
- ❁ Thinning to 156 (± 2) μm was done by Okamoto.
- ❁ Bump deposition and flip-chipping was done by AMS.
- ❁ Digital test - OK.
- ❁ Analog scan - very few dead channels.

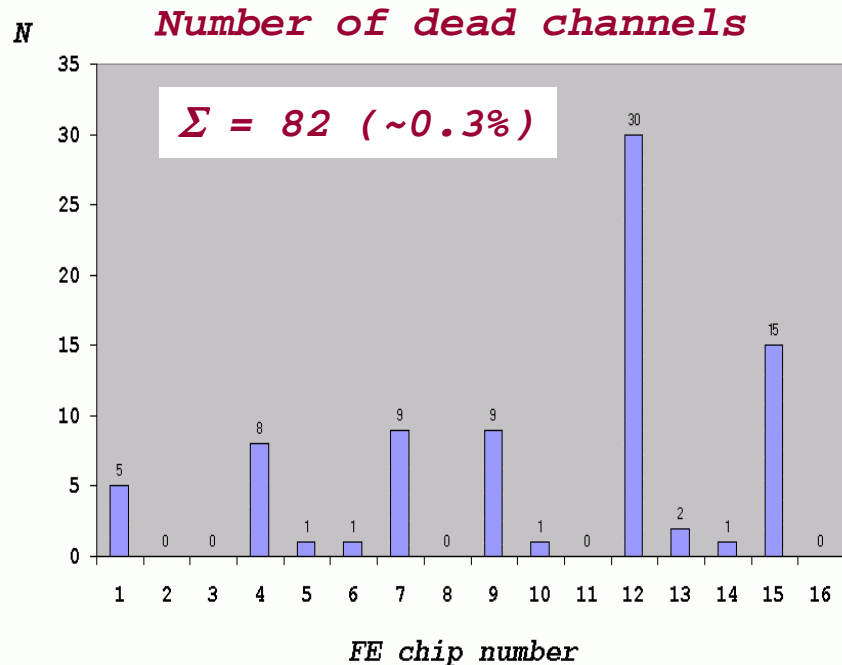
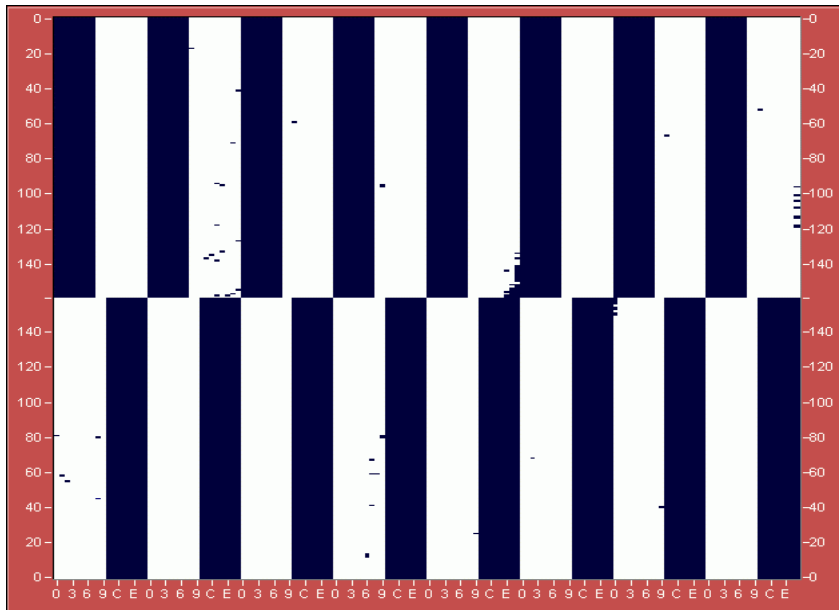

Thin Module 2: Threshold and Noise.

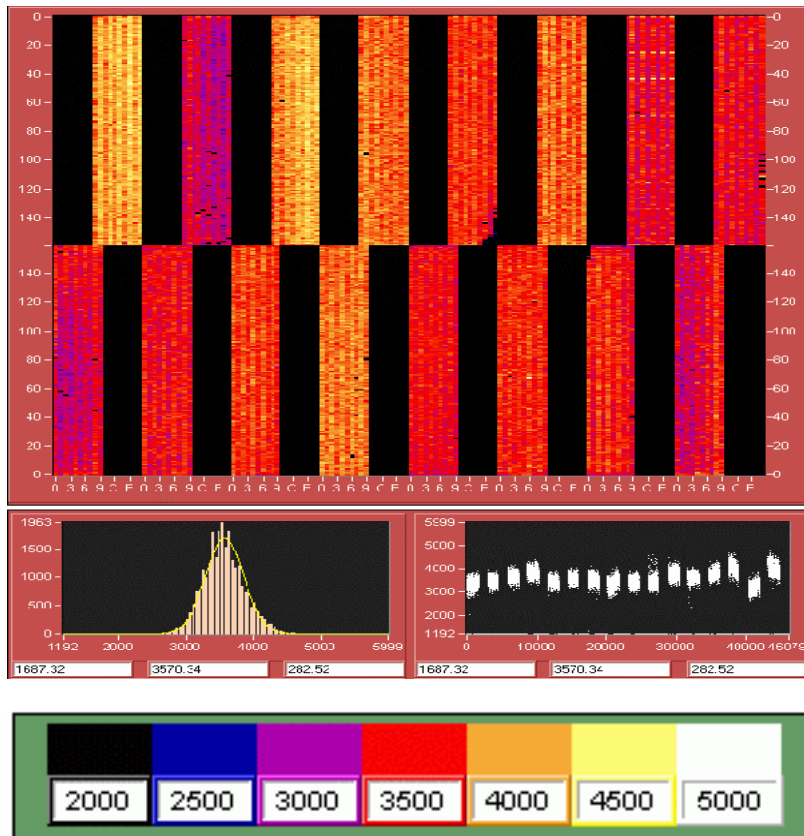

Threshold plot.

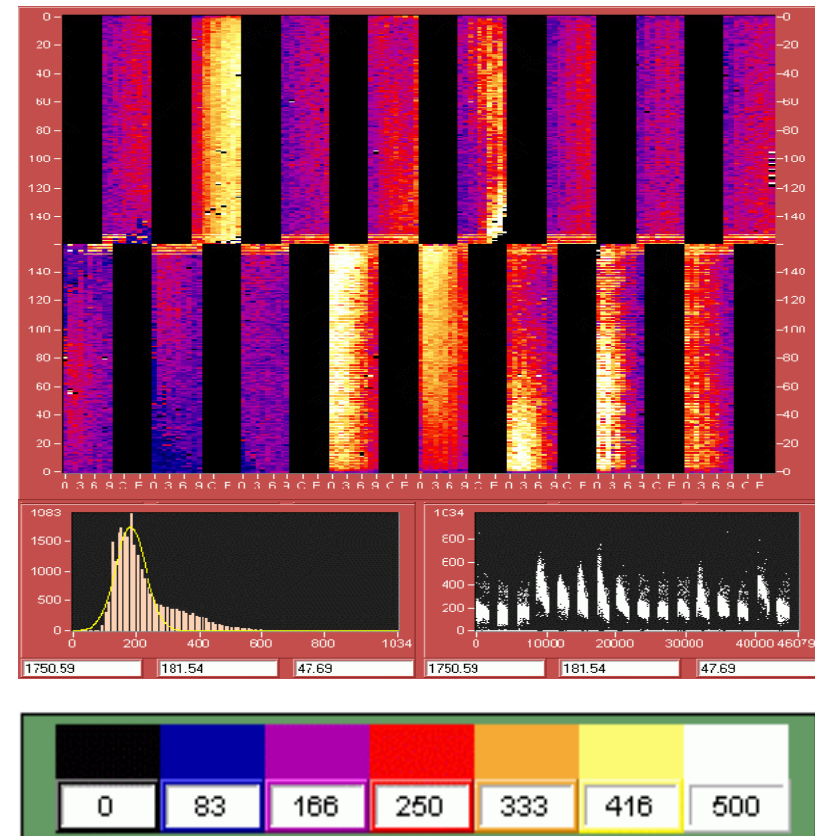

Noise plot.

Thin Module 2: Mean values for 16 FE-s

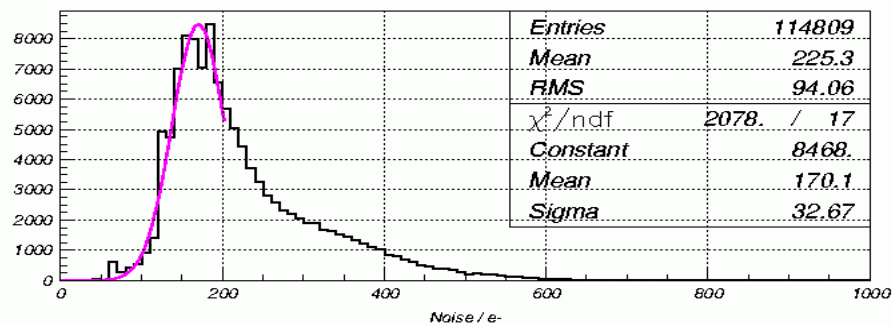
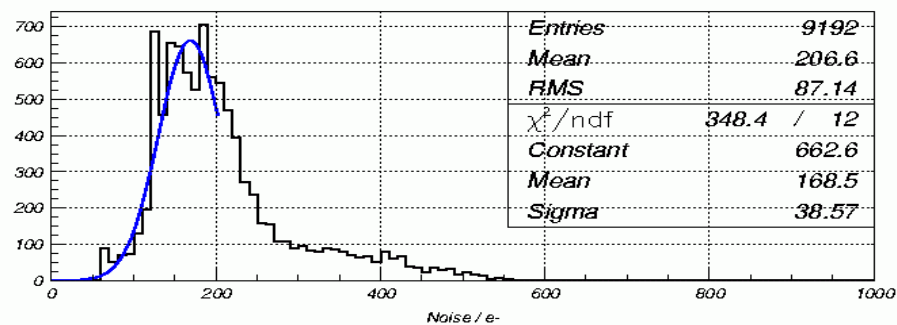
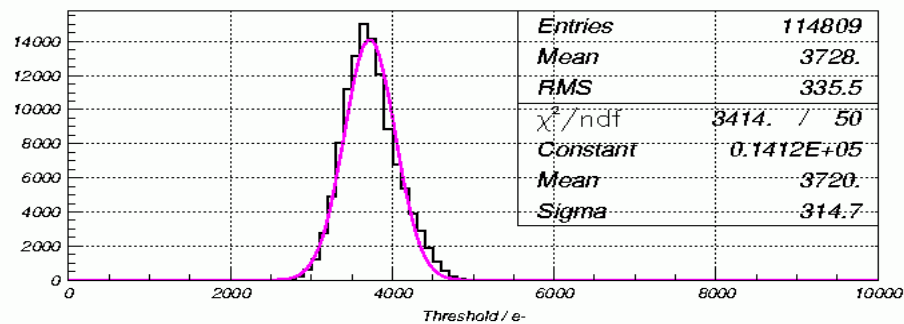
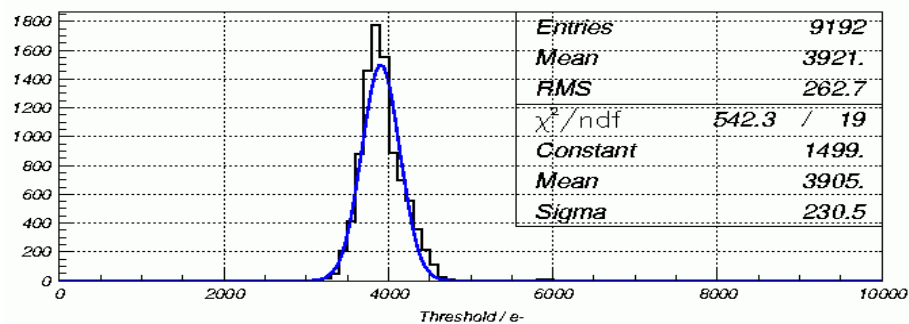

1 measurement

✿ Threshold $3900e \pm 260e$

✿ Noise $\sim 210e$

10 measurements

✿ Threshold $3700e \pm 300e$

✿ Noise $\sim 225e$

Thin Module 2: Stability plot

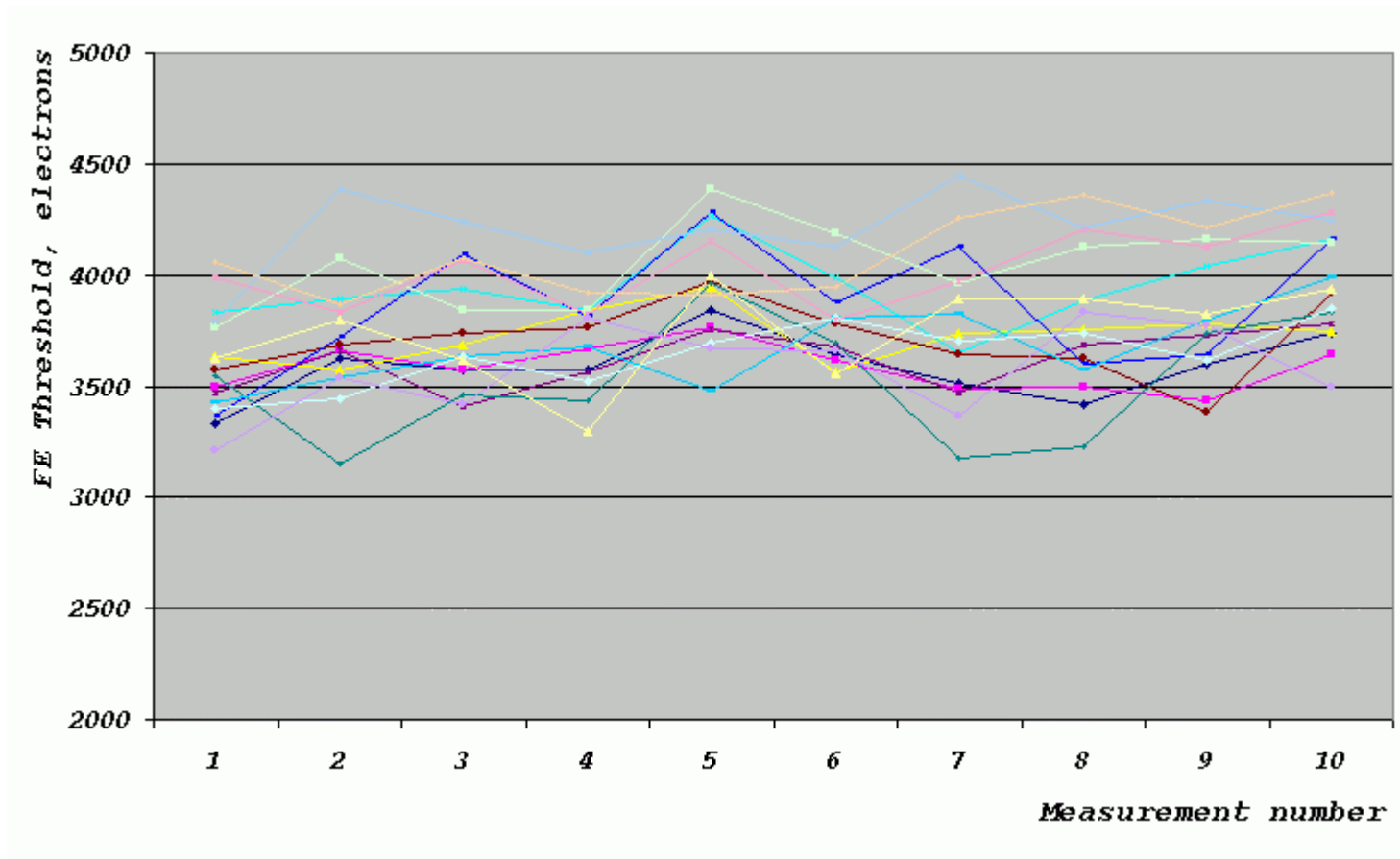

Thin Module 2: Source (^{109}Cd) tests.

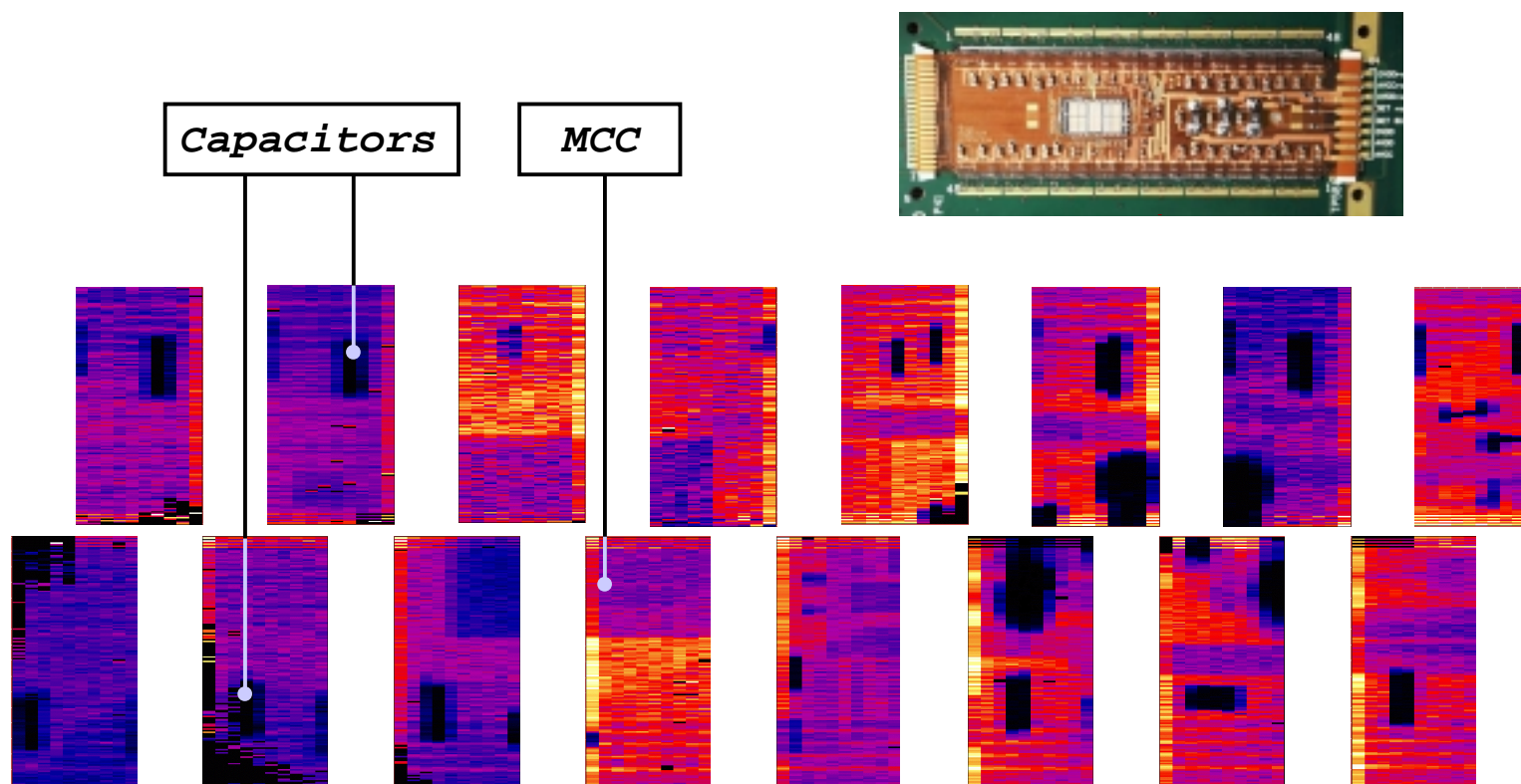

MCC and electronic components are visible.

Thin Module 2: micro-radiography analysis of defects.



X-rays

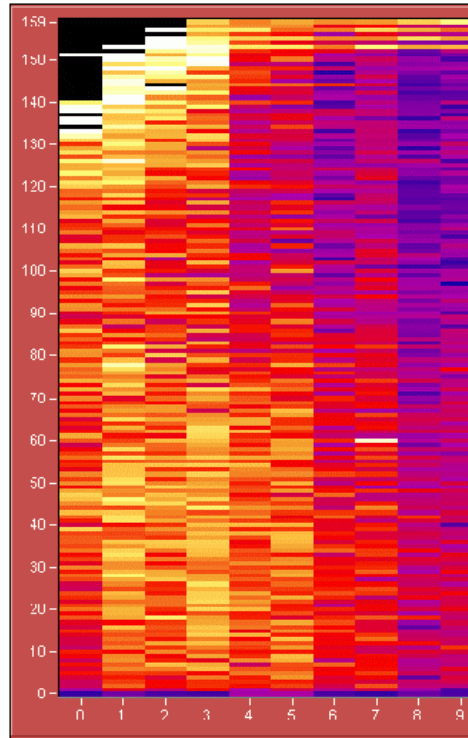

Noise

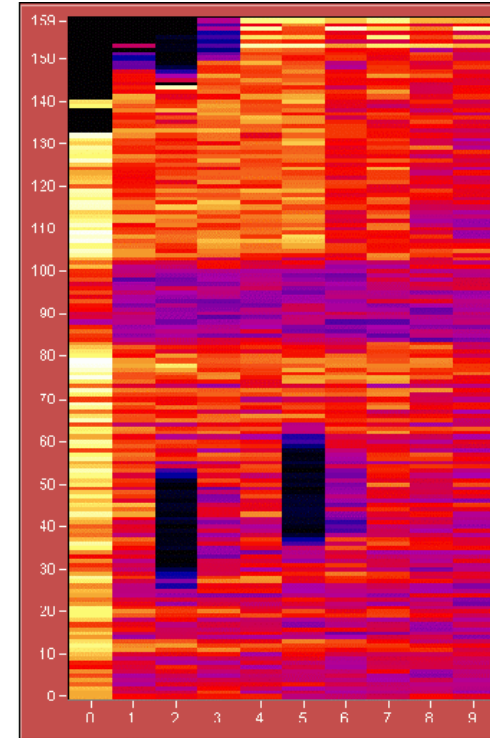

Source scan

Results on Thin Module 3 (INFN Genova + AMS) May 2000.



- ❁ Thinned to 150 μm electronics FE_B.
- ❁ Bump deposition and flip-chipping was done by AMS.
- ❁ Digital test - OK.
- ❁ Analog scan - very few dead channels, but FE#2 did not work properly.

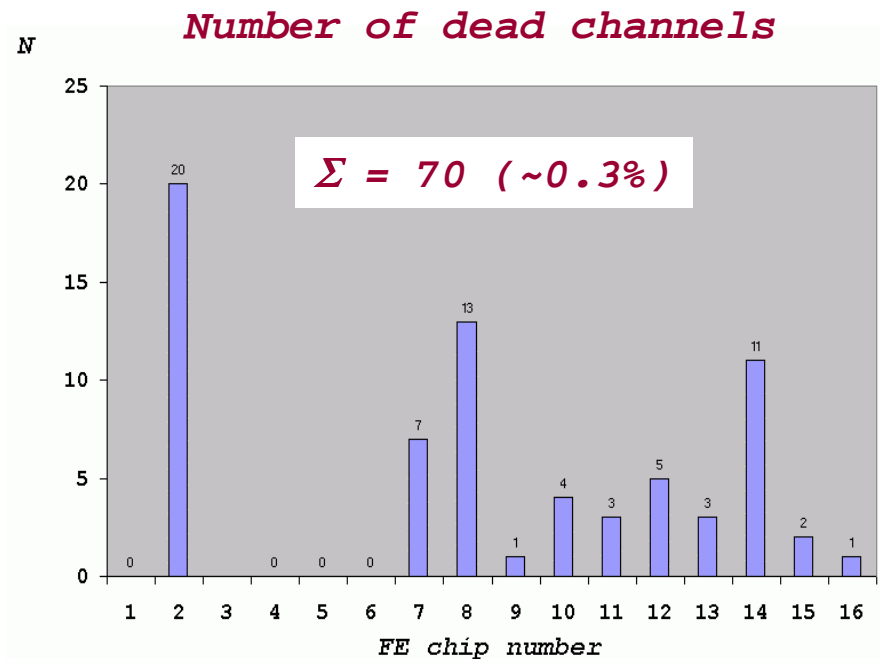
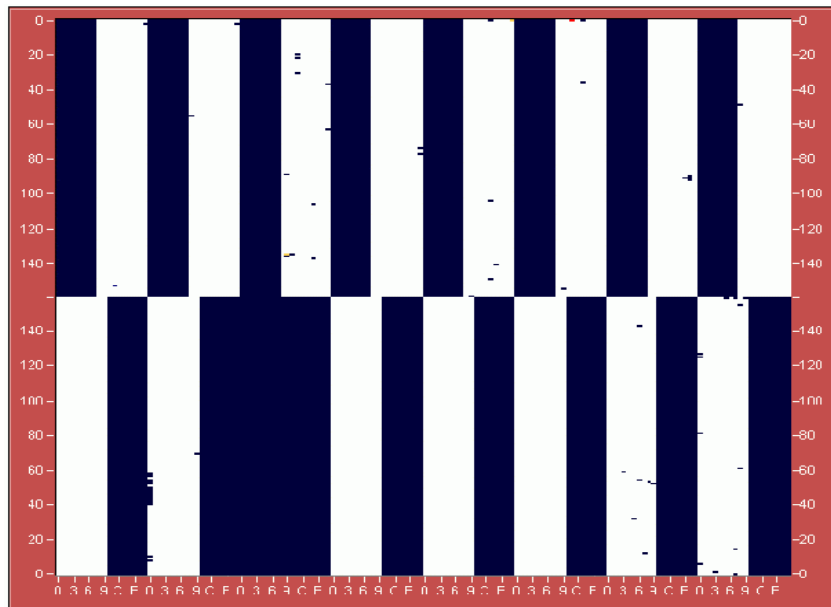

Thin Module 3: Threshold and Noise.

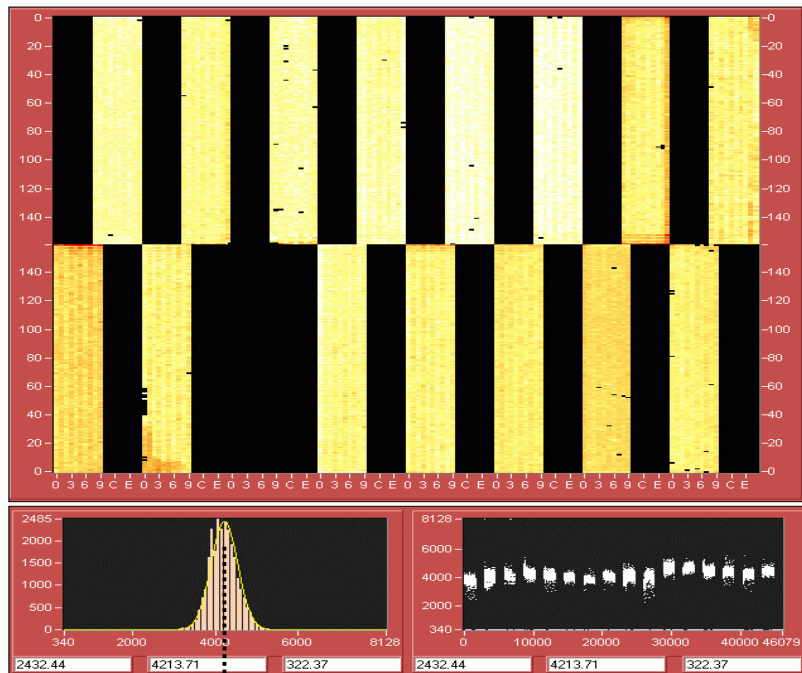

$4200e \pm 330e$



Threshold plot.

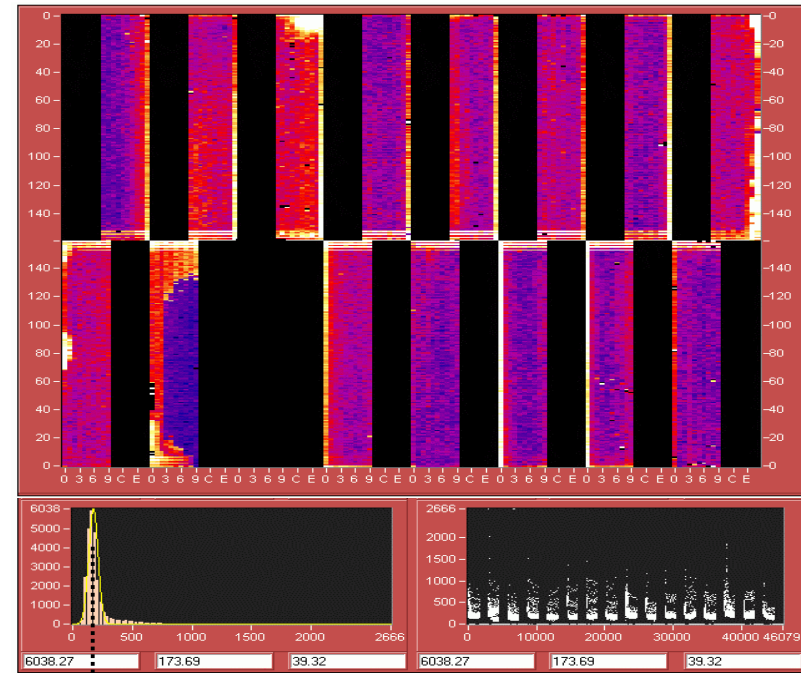

180e

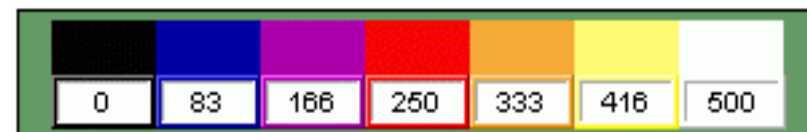

Noise plot.
FE#1 - detached bumps

Thin Module 3: Mean values for 16 FE-s

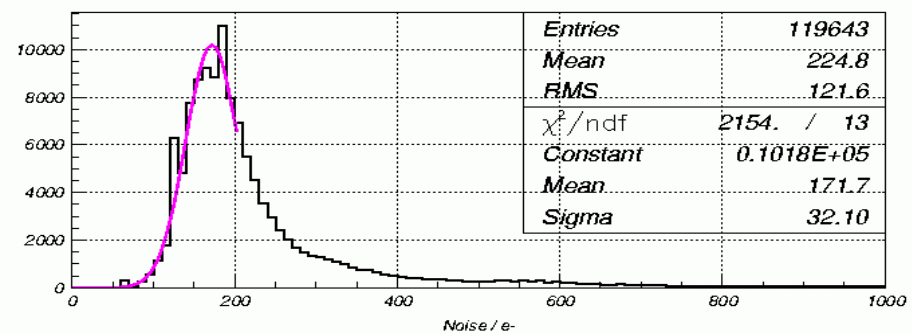
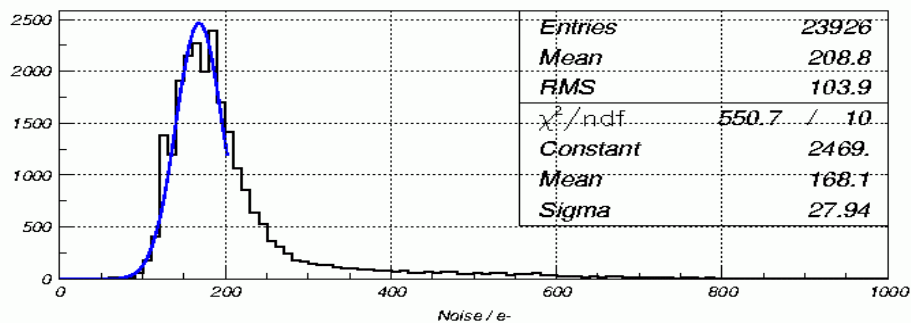
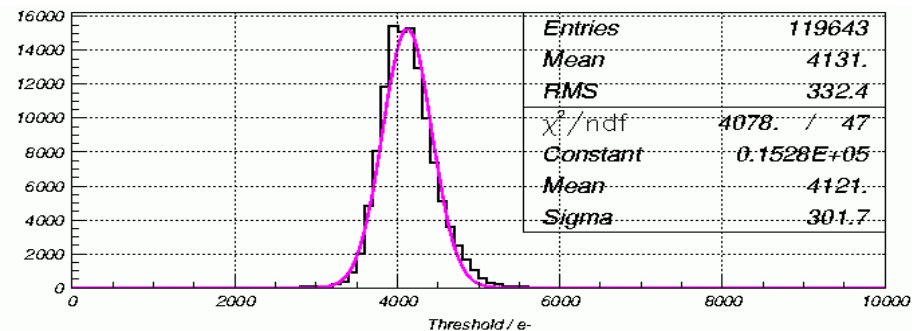
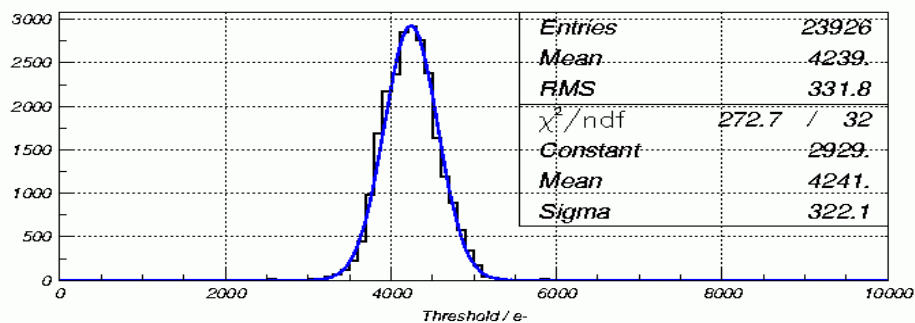

1 measurement

✿ Threshold $4200e \pm 330e$

✿ Noise $\sim 210e$

10 measurements

✿ Threshold $4200e \pm 330e$

✿ Noise $\sim 225e$

Test Beam at CERN (H8) 24 - 31 May 2000

Preliminary Results

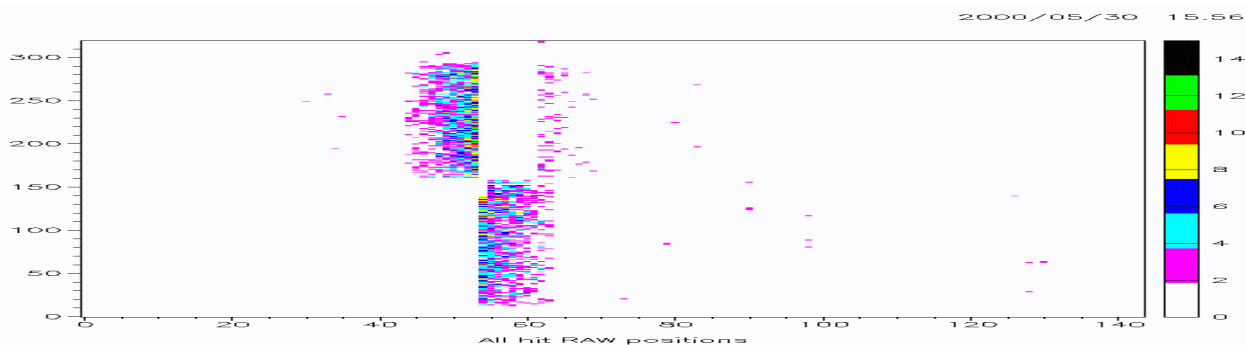

Online plots:
beam spot

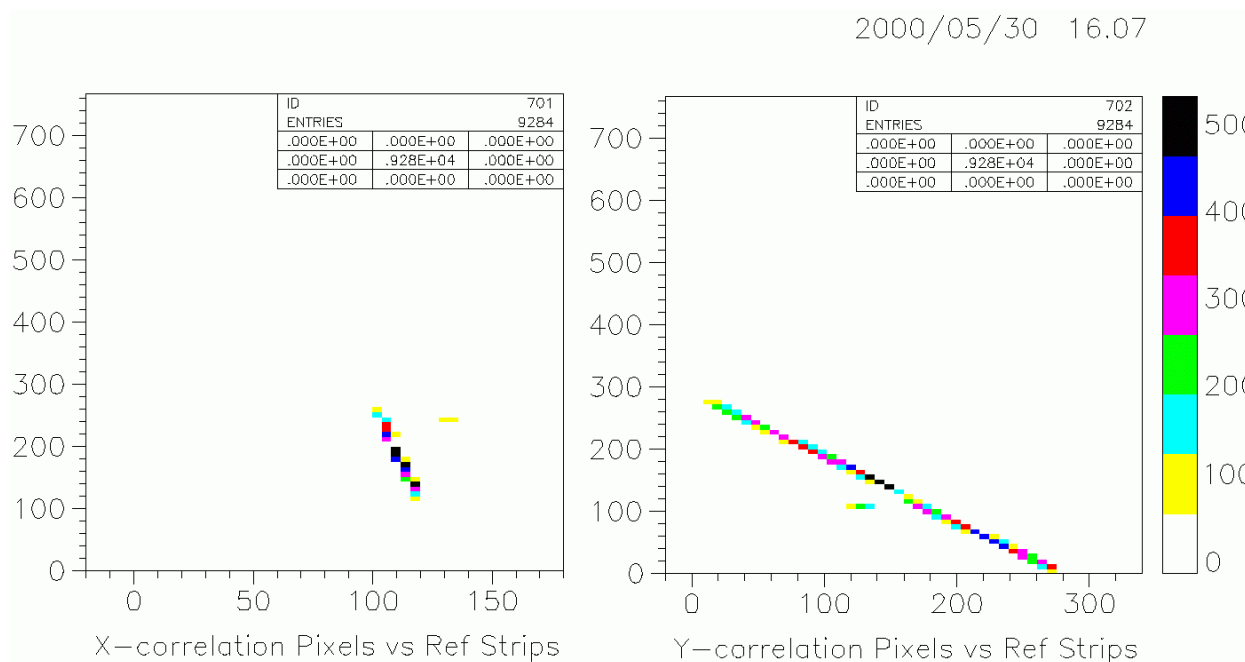

Online plots:
Module \leftrightarrow Beam
microstrips
data correlation

Conclusions

- 4 *0.7% X0 (meeting Pixel TRD specification) 16 FE-chip module has been built.*

- 4 *It works with*
 - high yield (~0.3% of dead channels)*
 - low threshold ($3700e \pm 300e$) and noise (~ 220e) values.*