

# DEPFET Pixel: A Pixel Device with Integrated Amplification



Johannes Ulrici  
Bonn University  
FAUST Semiconductor Lab



# Outline

---

- The DEPFET-Principle
- Measurements on DEPFET Single Pixel Devices
- First Measurements with a DEPFET Pixel Array (64x64)  
(Applications: Autoradiography, High Energy Physics,  
X-Ray Astronomy)
- Summary

In cooperation with the MPI semiconductor Lab Munich, Bochum University, Dortmund  
University,  
funded by the DFG and by the NRW department of Science

# DEPFET - principle idea

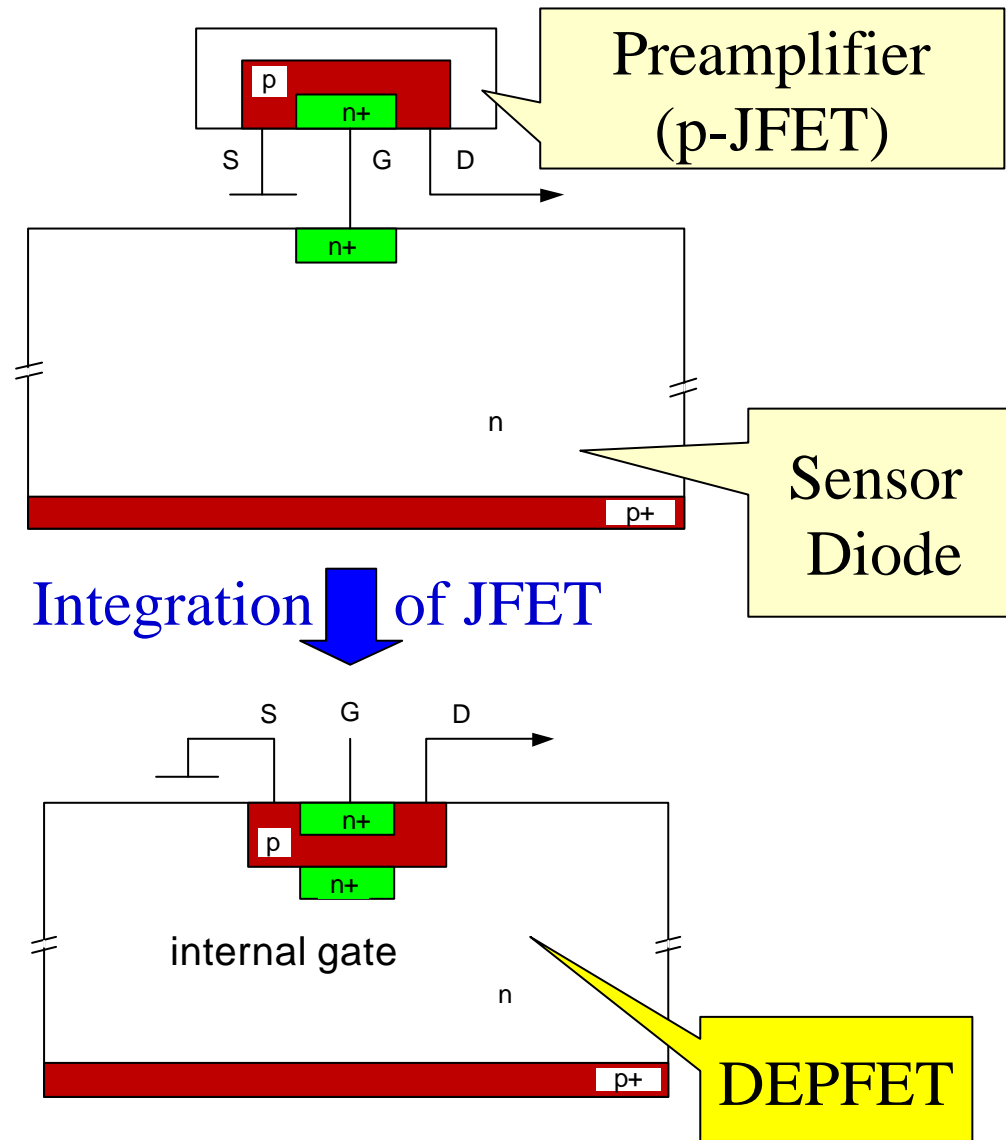

Kemmer, Lutz (1987):

- integrate preamplifier into Sensor Si- Substrate

Advantage:

- Small input capacitance
- no stray capacitance

=> Large Signal to Noise Ratio

# DEPFET - charge collection

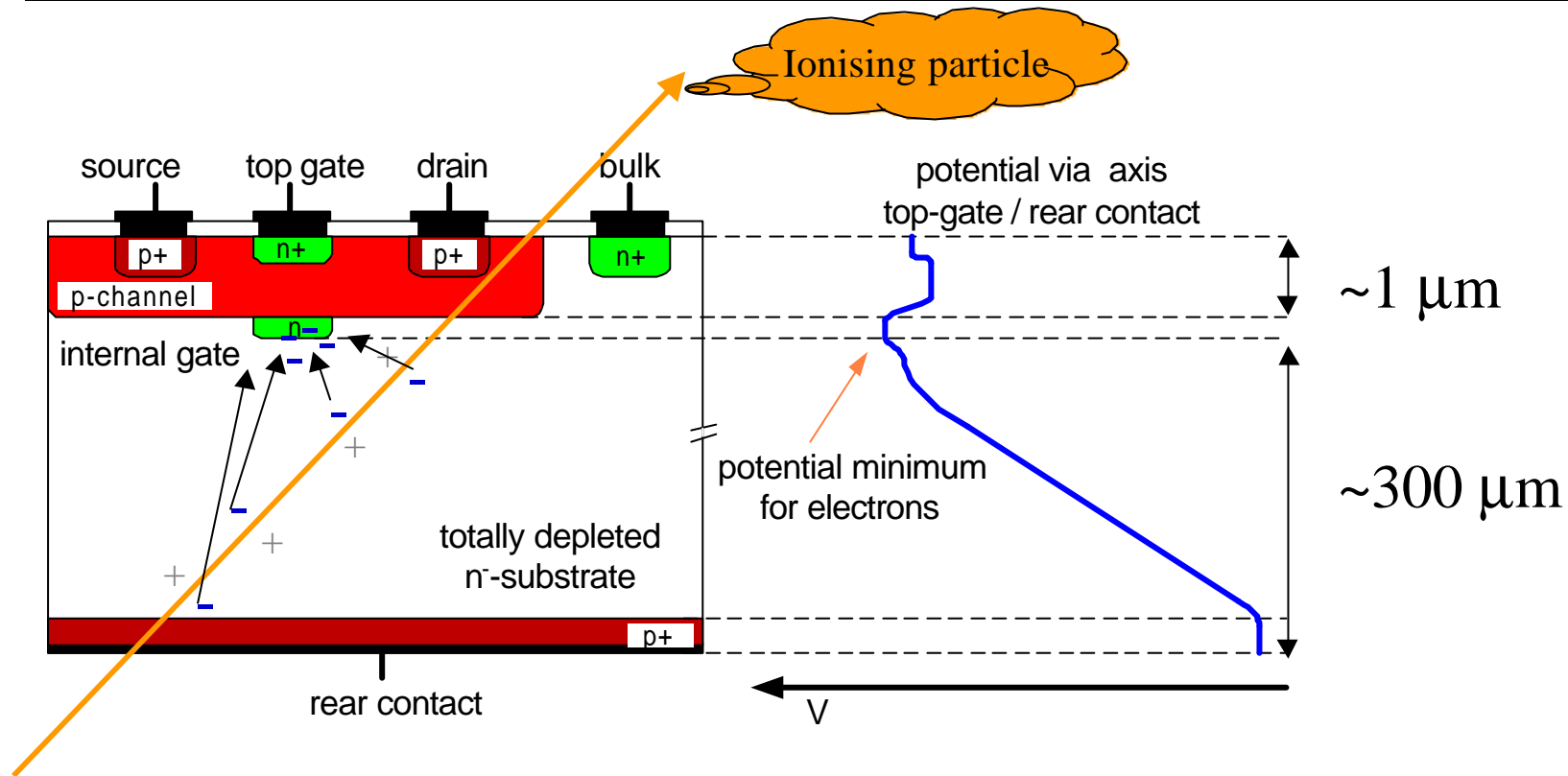

- sidewards depletion
- **electrons** collected in internal gate
- channel current of **JFET** modulated by signal charges

# DEPFET - Clear Mechanism

- Internal gate filled by signal charges and thermally generated electrons
- „Reset“ needed
- One possibility:  

pulsed clear!
- Other clear mechanisms:  
    cont. clear, gate clear, ...

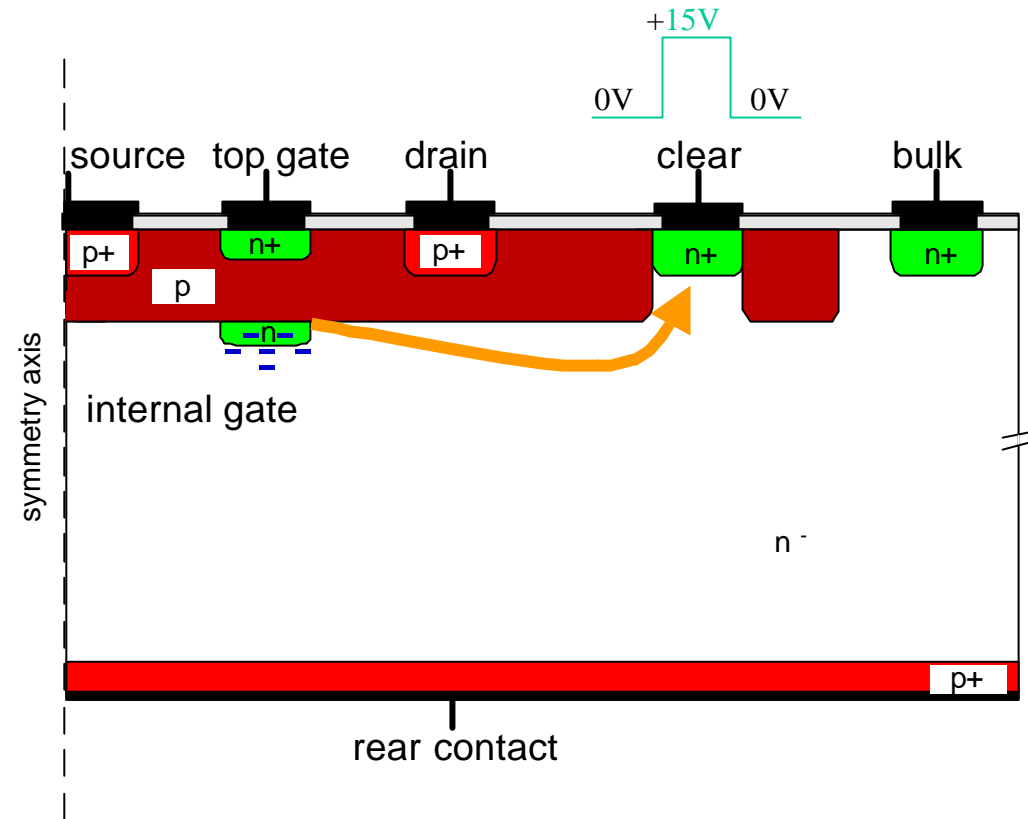

pulsed clear: dead time less than 0,1% of measuring time

# DEPFET - Measurements on Single Pixel Devices

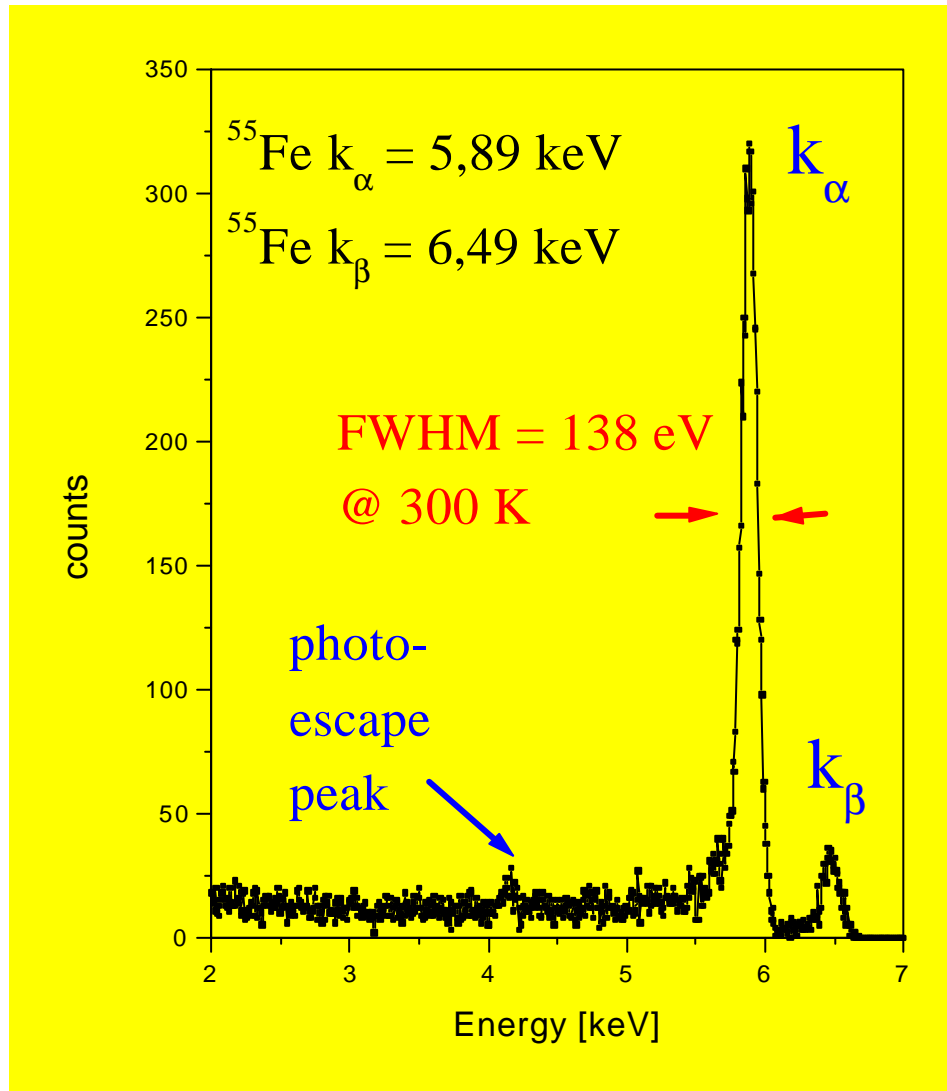

Spectrum of  $^{55}\text{Fe}$ -Source:

- At room temperature (300 K)
- Shapingtime:  $10\mu\text{s}$
- Noise Peak  $\sigma = (6,1 \pm 0.1) e^-$
- $K_\alpha$ -Gaussfit  $\sigma = 16,1 e^-$  or FWHM = 138 eV
- low energy tail due to split events (pixel size  $50 \times 50 \mu\text{m}$ )

Noise: ENC = 6.1e @ 300K

# Layout of DEPFET-Matrix

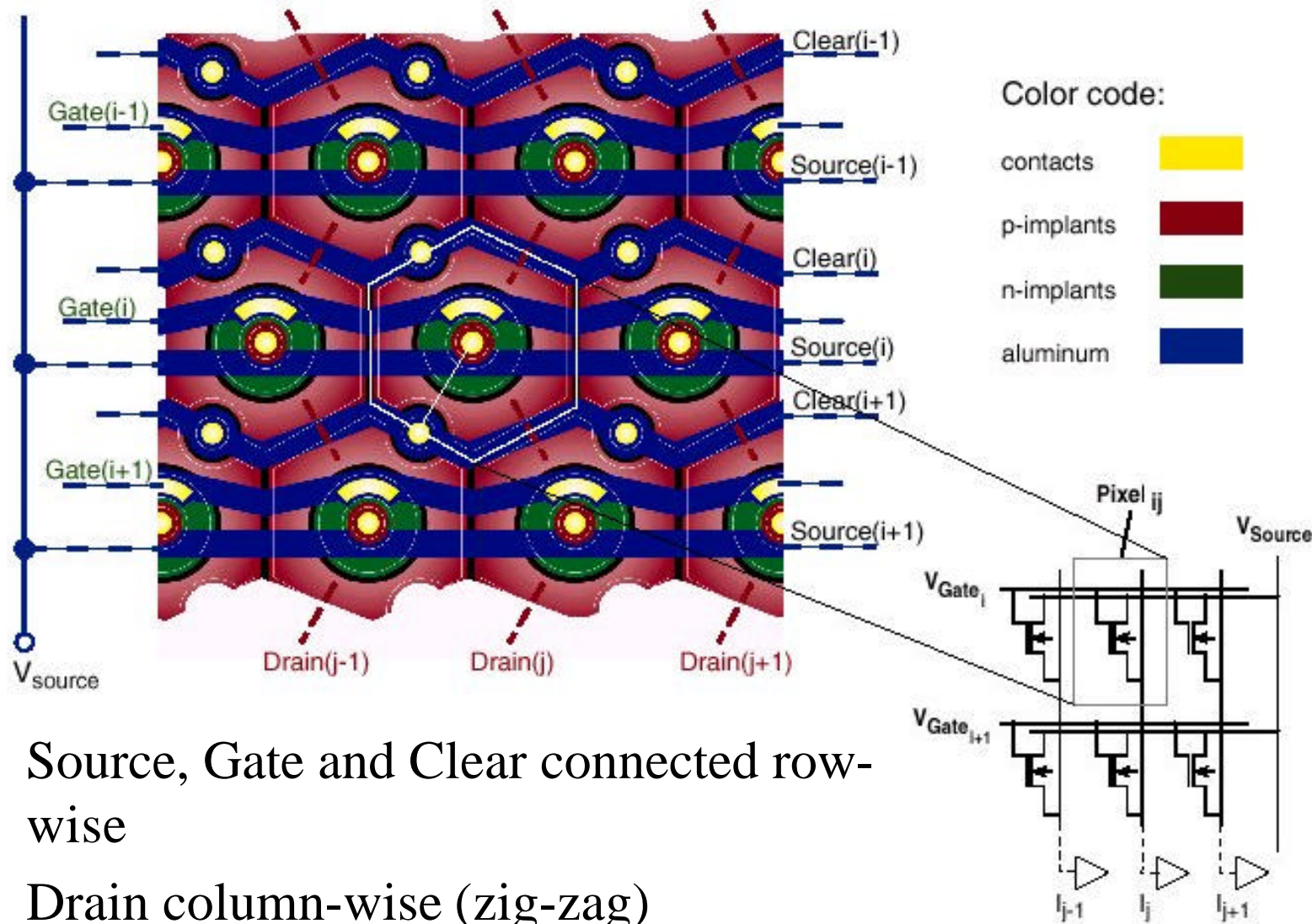

- Source, Gate and Clear connected row-wise
- Drain column-wise (zig-zag)
- bond pads on end of columns/rows

# DEPFET - Matrix Data Acquisition

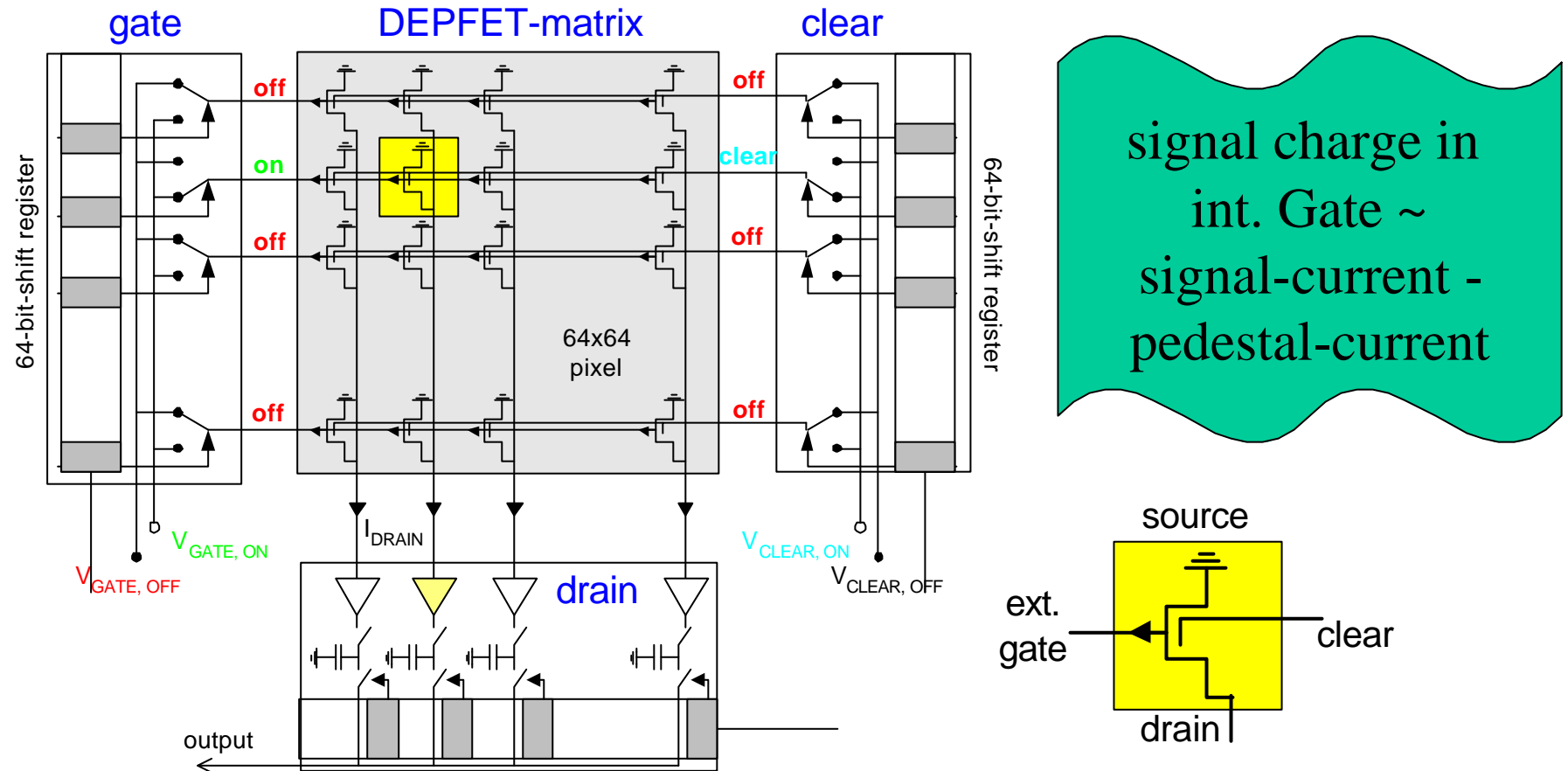

- switch on one row through gate contacts, get pedestal current
- after doing this for all rows, switch row on again, get signal current
- clear this row



# DEPFET - Bioscope

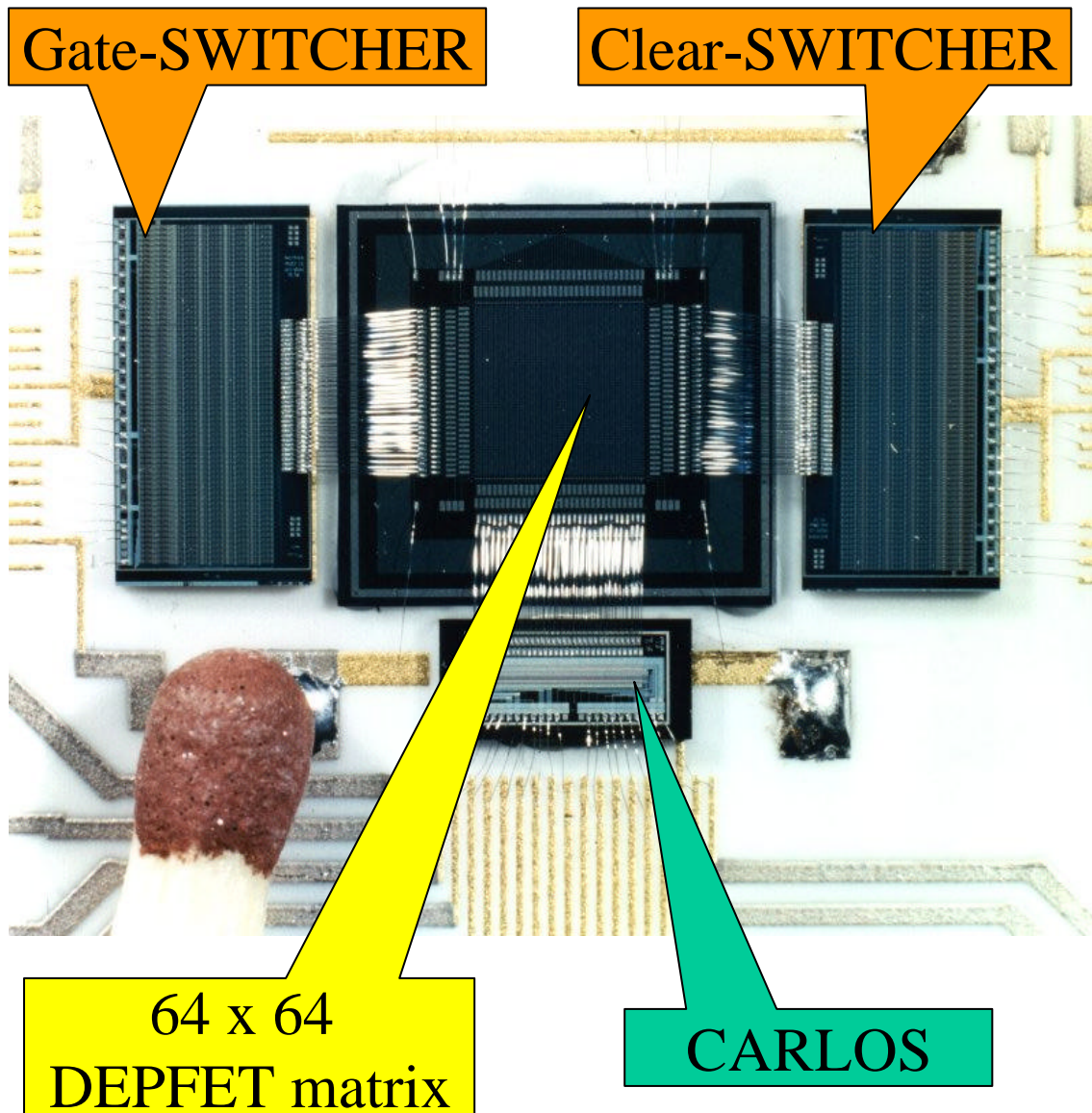

Developed ASICs:

## CARLOS:

- low-noise 64-channel amplifier
- track & hold
- 10 MHz Serializer (64 to 1)

## SWITCHER:

- 64 channels, 65MHz
- AMS 25V HV-technology

## further components:

- analog PBC with 12-bit ADC
- digital PBC with XILINX for data acquisition

1 image (64x64 Pixel) per 1ms

# DEPFET Pixel Bioscope System

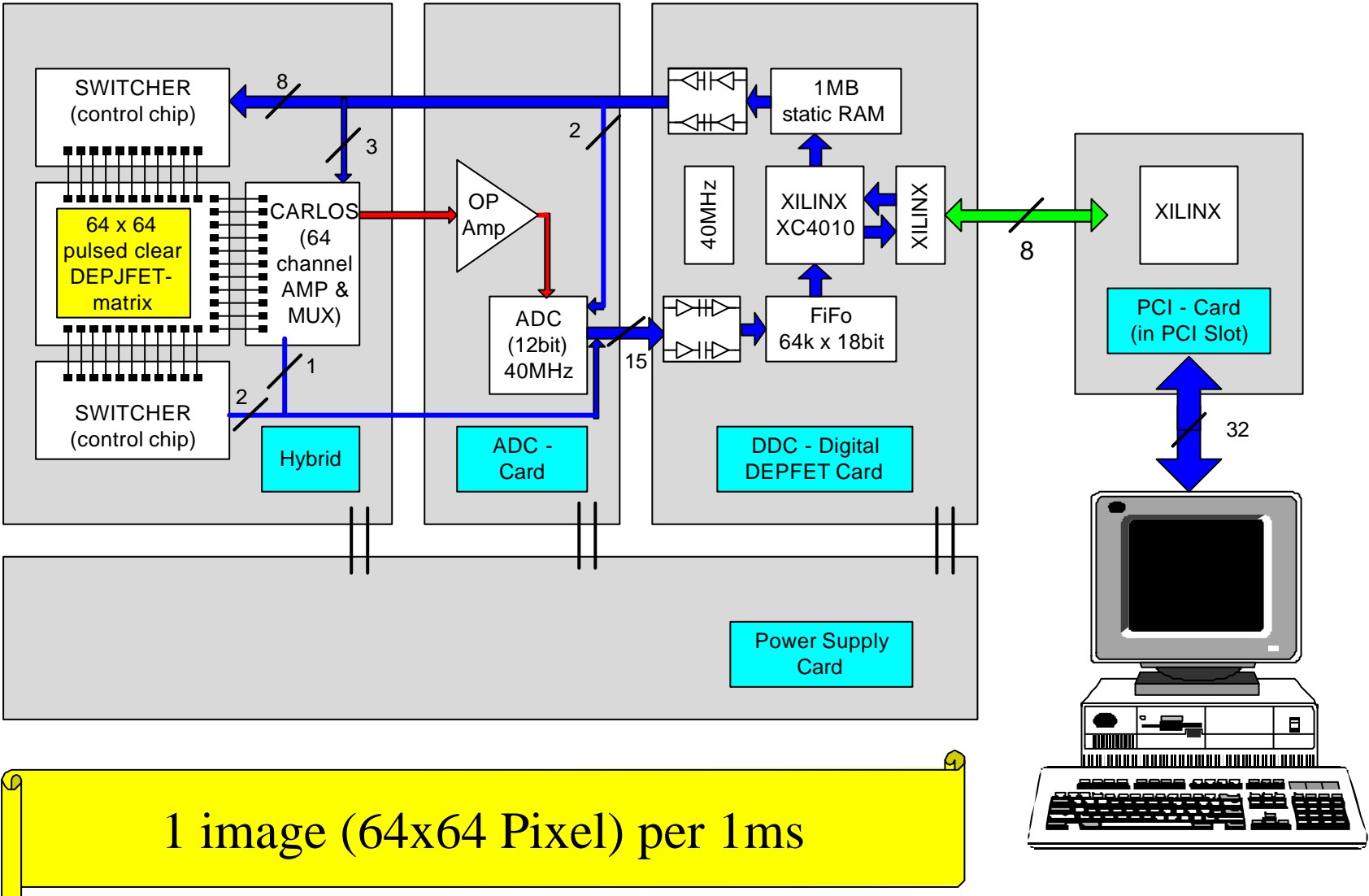

# The DEPFET Pixel Bioscope

---

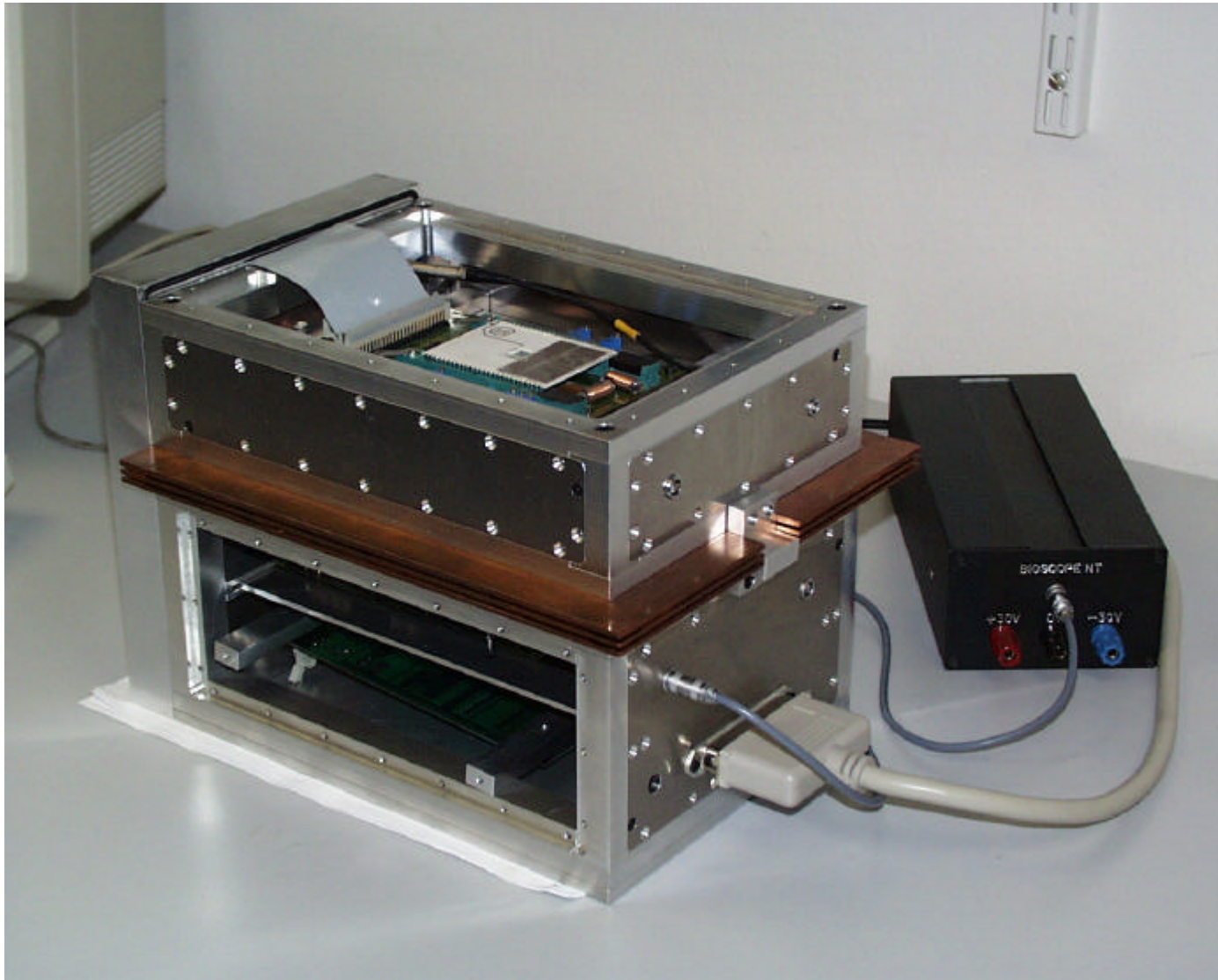

# X-Ray images: 64x64 Matrix, 50x50 $\mu\text{m}^2$ Pixel

Shadow image of toothed wheel of watch,  $^{55}\text{Fe}$ - $\gamma$ -Source (6keV)

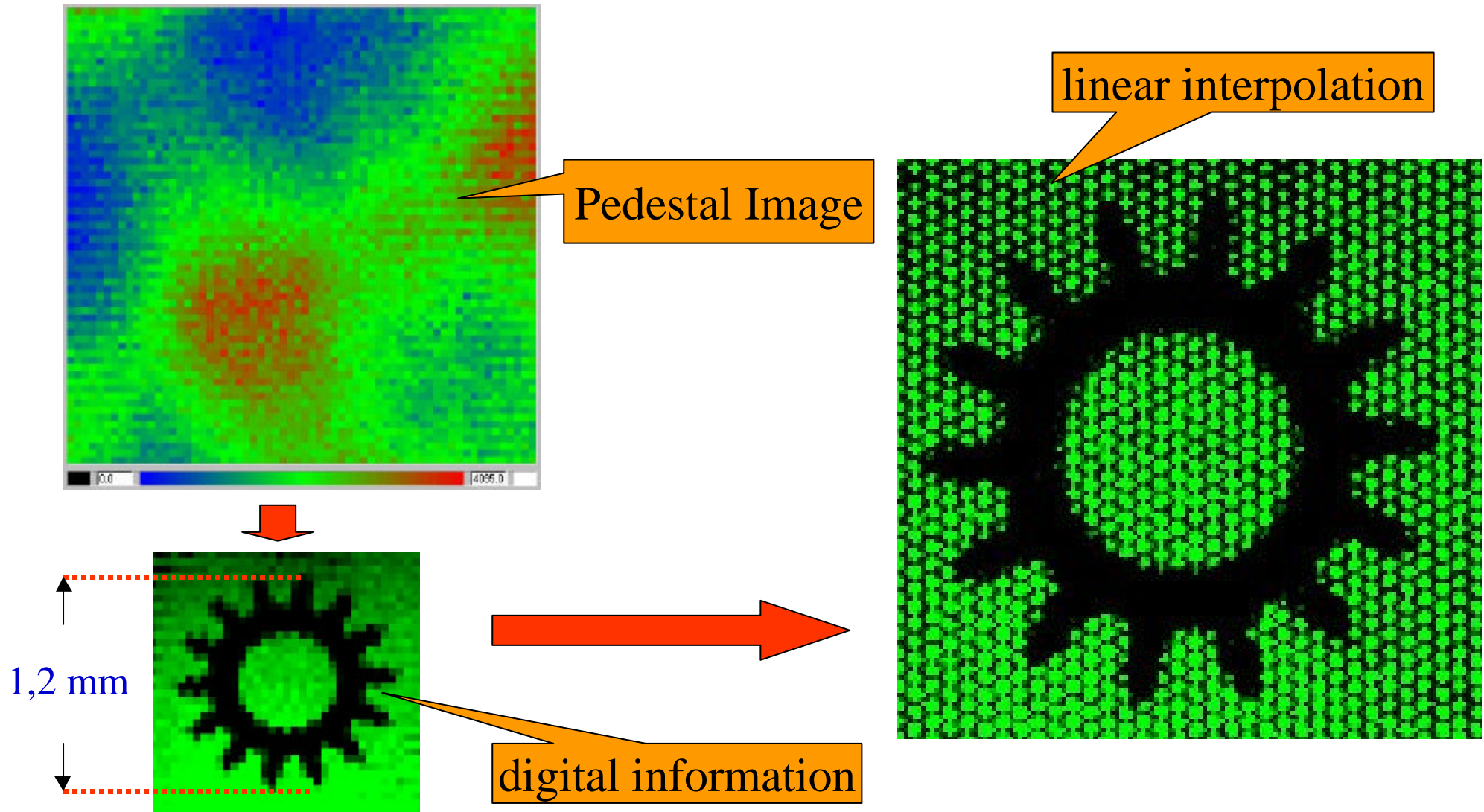

# DEPFET - Charge collection efficiency

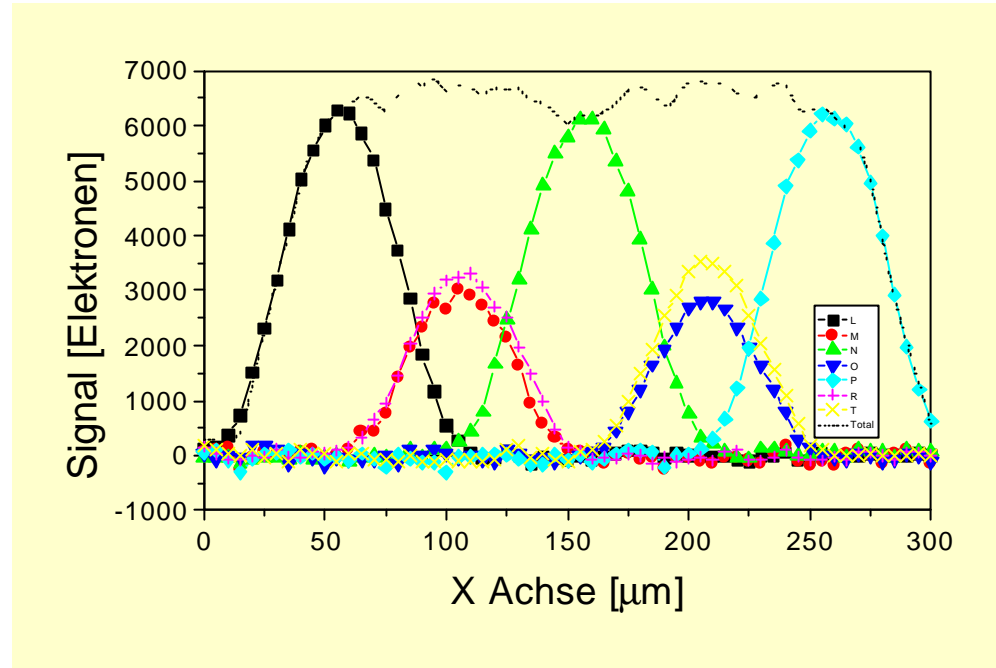
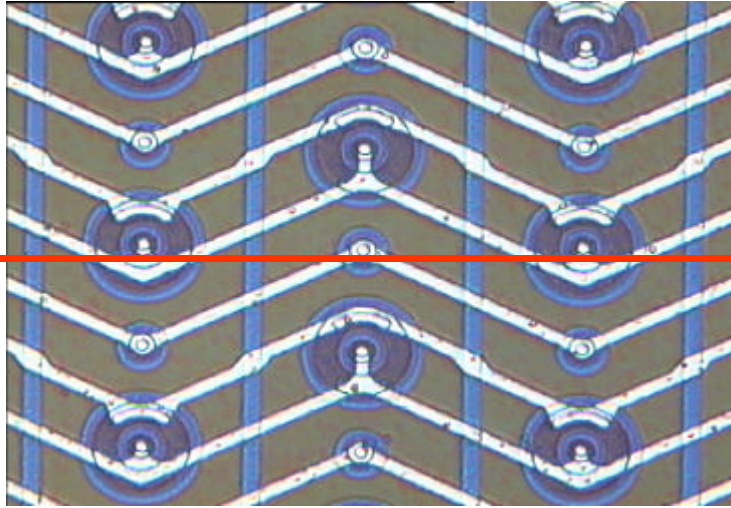

Laser Scan across matrix with bricked pixel layout ( $50 \times 50 \mu\text{m}^2$ )

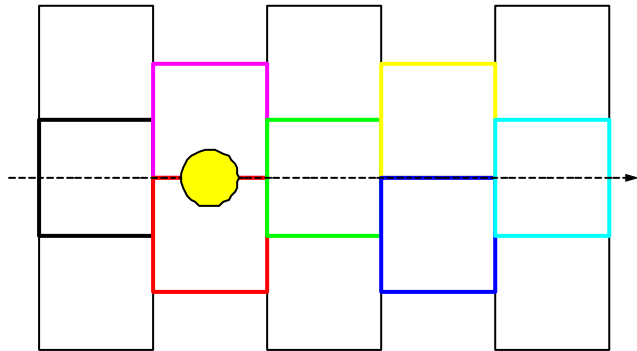

homogeneous charge collection efficiency!  
(no charge loss into clear contacts)

# DEPFET - linearity and noise

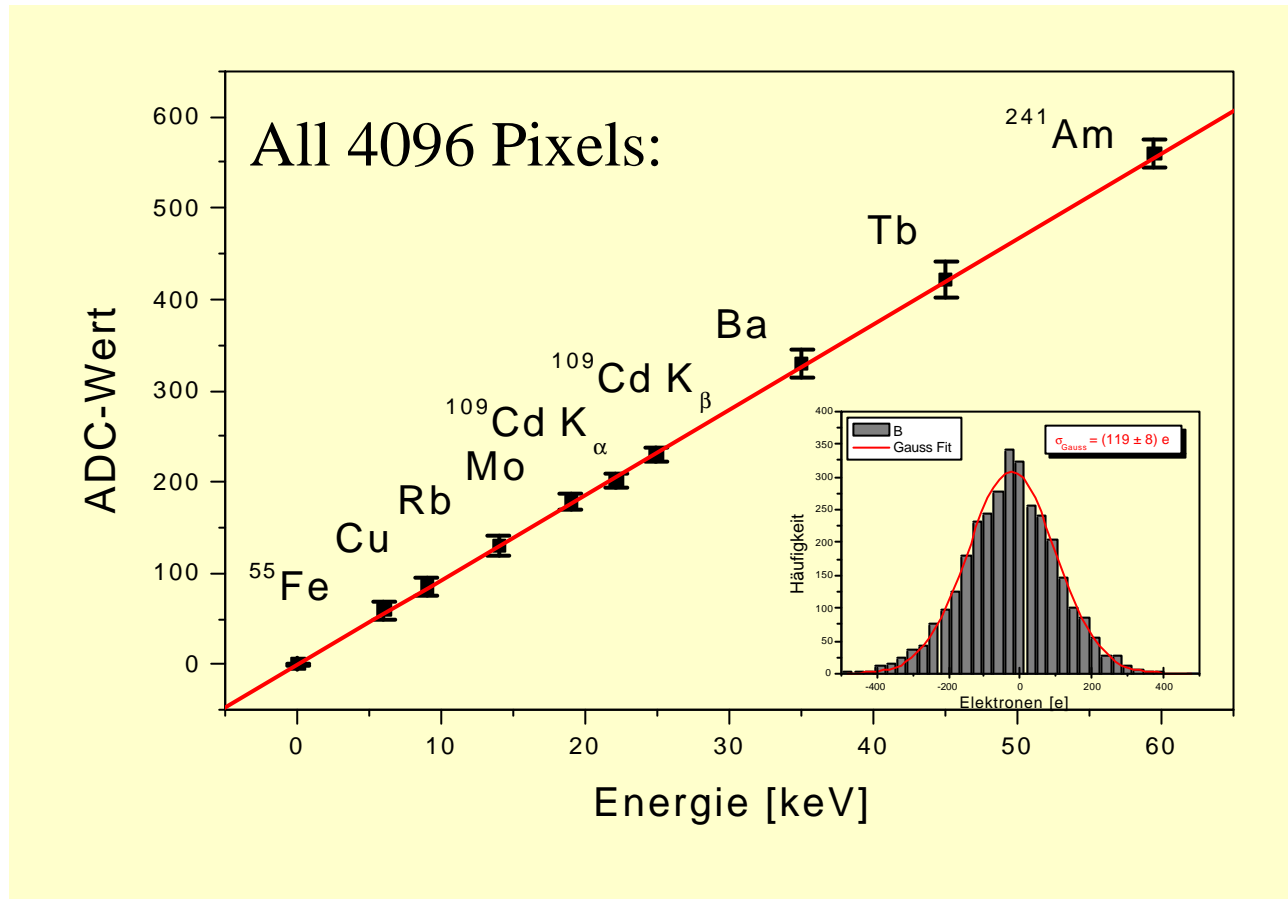

very good linearity [6 - 60keV]  
low noise of single image:  $\sigma_{\text{noise}} = 84 \pm 6 e$

# Tritium-Detection: 64x64 DEPFET-Matrix

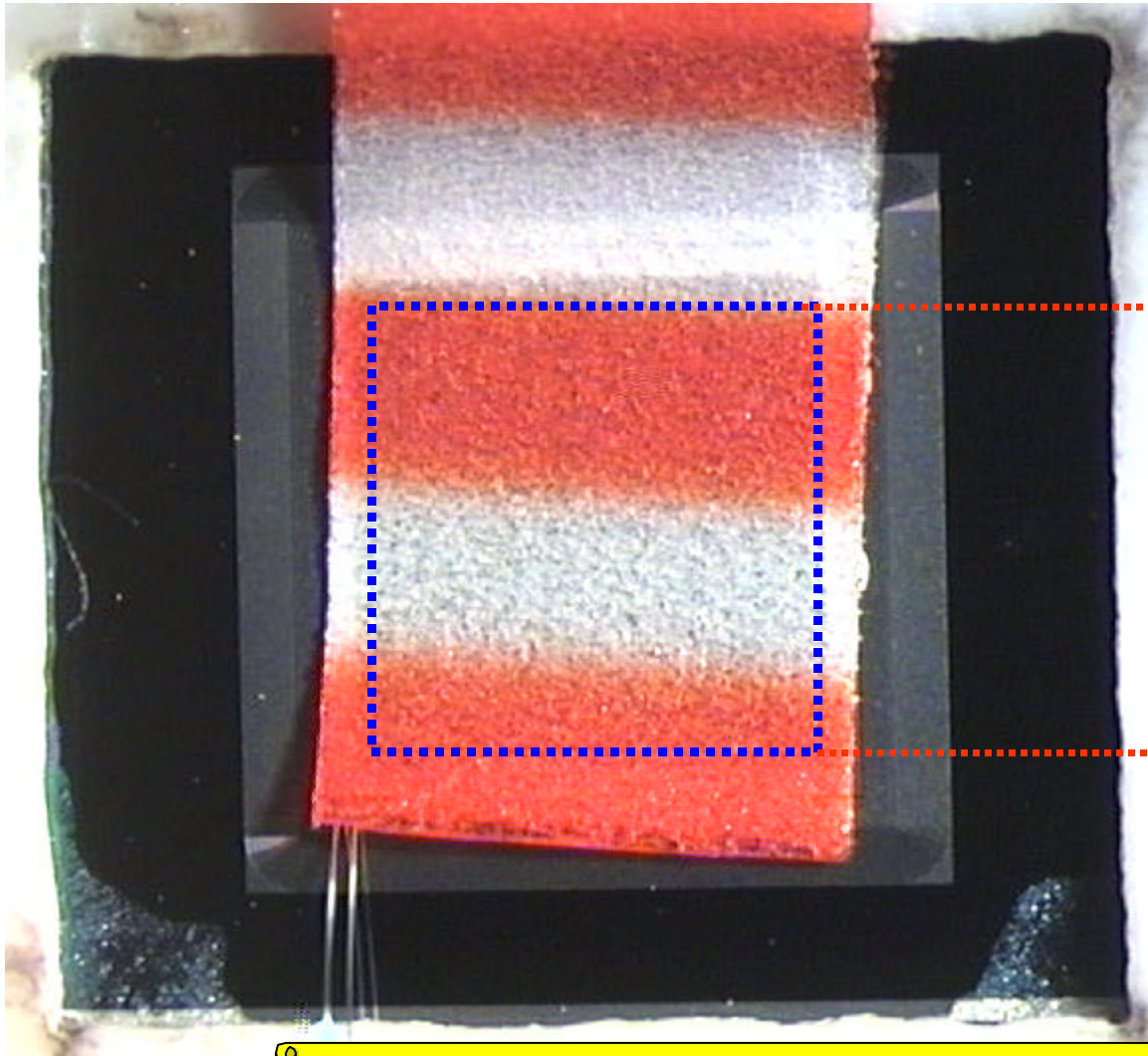

$^3\text{H}$ -Microscale (30 Bq per block)  
(18keV  $\beta$ -endpoint-energy)  
24h measurement

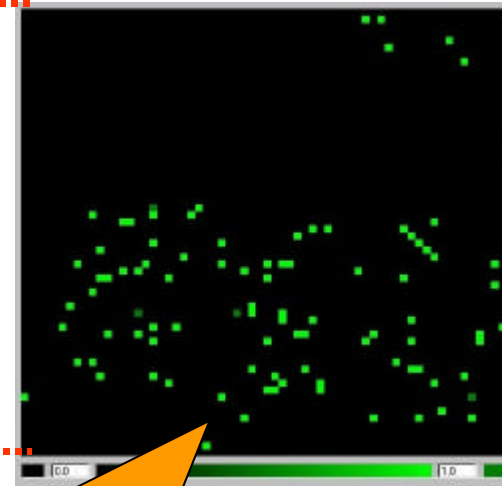

$^3\text{H}$ -radiograph

Tritium-detection possible ( $8\sigma$  threshold) !!!

# Spatial Resolution with $^{55}\text{Fe}$ -Source

75 $\mu\text{m}$  thick tungsten sample,  $^{55}\text{Fe}$ -6keV-source

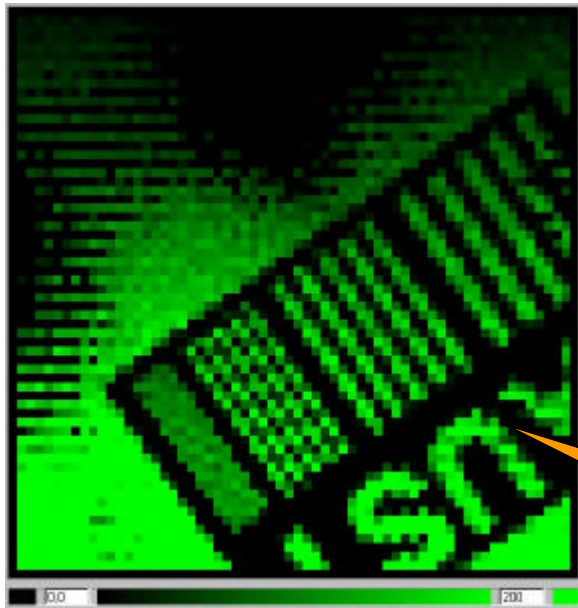
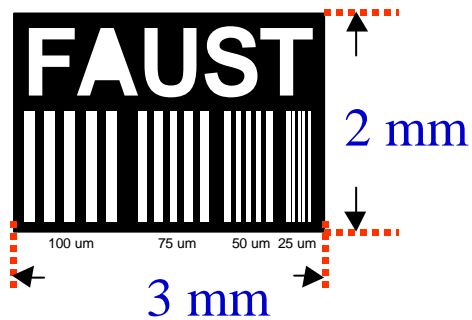

digital (50x50  $\mu\text{m}^2$ )

linear interpolation  
(1Pixel =  
12.5 x 12.5  $\mu\text{m}^2$ )

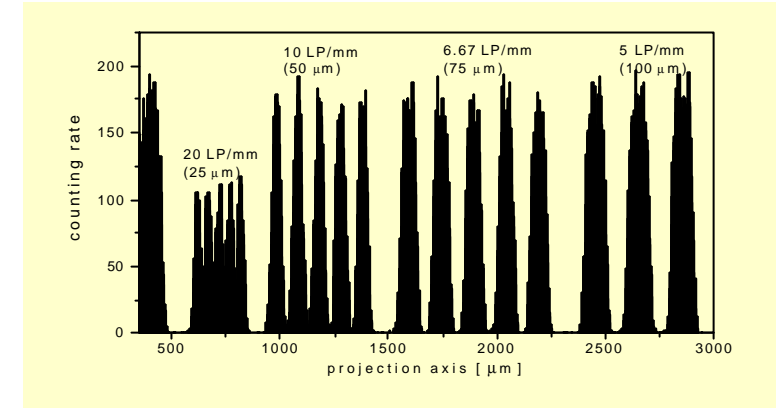
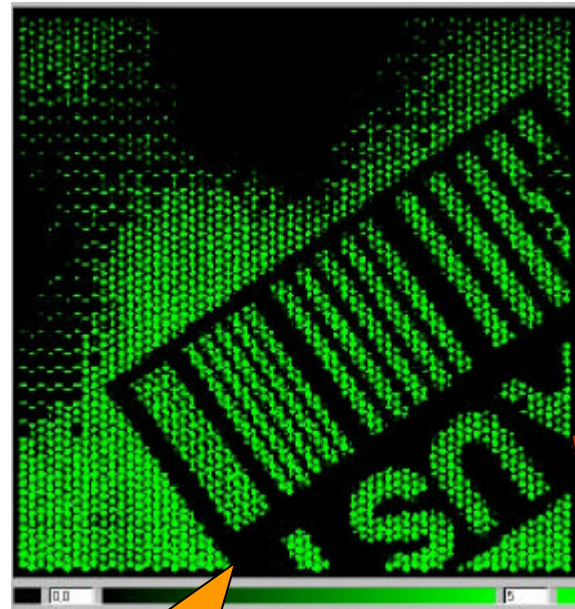

28 LP/mm resolution!

Spatial Resolution

$$\sigma_{\text{gauss}} = 9,0 \pm 0,6 \mu\text{m}$$



# DEPFET - Performance Summary:

---

- very good SNR ( $> 80$  @ 6keV)
- 200 nm thin, homogeneous entrance window
- non-destructive readout  $\rightarrow$  multiple readout possible
- very fast readout, partial readout of matrix possible
- small deadtime ( $< 0,1$  % of Data Acquisition time)  
 $\rightarrow$  high efficiency
- small pixel size ( $50 \mu\text{m}$ )

# DEPFET - Applications:

---

## Biomedicine (Autoradiography):

- Real time detection of  $^3\text{H}$  at room temperature without vacuum
- Good energy resolution -> different radioactive markers

## X-Ray Astronomy (successor of XMM: XEUS)

- low energy  $\gamma$ 's
- high rates, nearly no dead time, no ghost hits

## Particle Physics (TESLA)

- thin detectors (30 $\mu\text{m}$ )
- small pixel size (30x30  $\mu\text{m}^2$ )

# Biomedical Application: Autoradiography

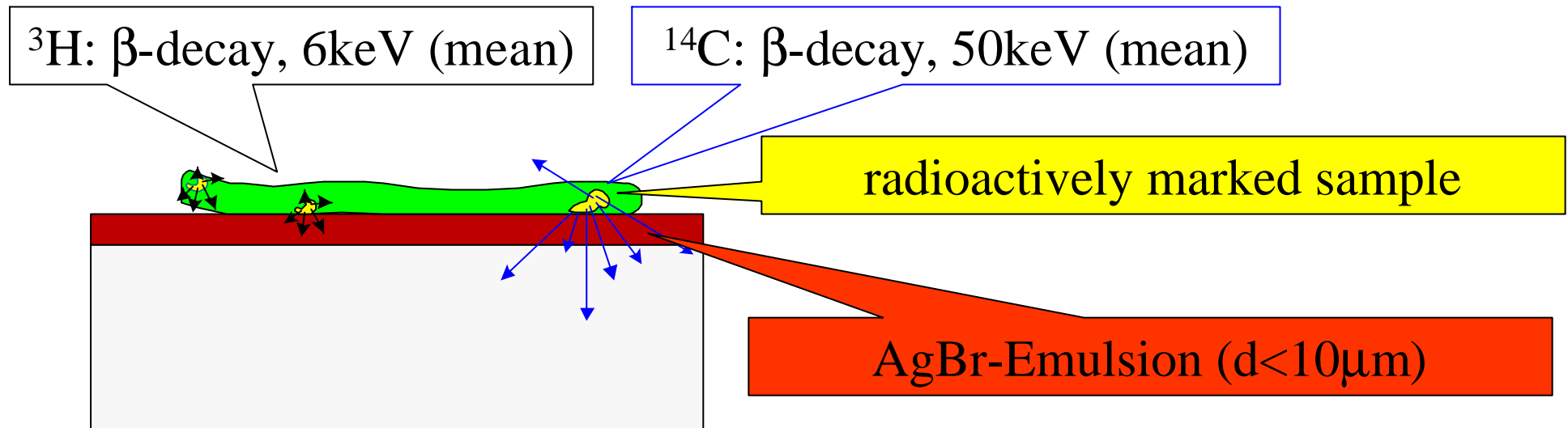

Good spatial resolution, no time or energy information

## Digital Autoradiography:

- **time resolved** -> real time observation of dynamic processes
  - > no development of film necessary (up to months)
  - > not sensitive to exposure time
- **energy resolution** -> different radioactive markers
- **DEPFET** -> detection of  $^3\text{H}$  (room temperature, no vacuum!)

# X-ray astronomy: XEUS (2010-2015)

XMM-successor: „X-ray Evolving Universe Spectroscopy“

pn-CCDs too slow for „Wide Field Imager“

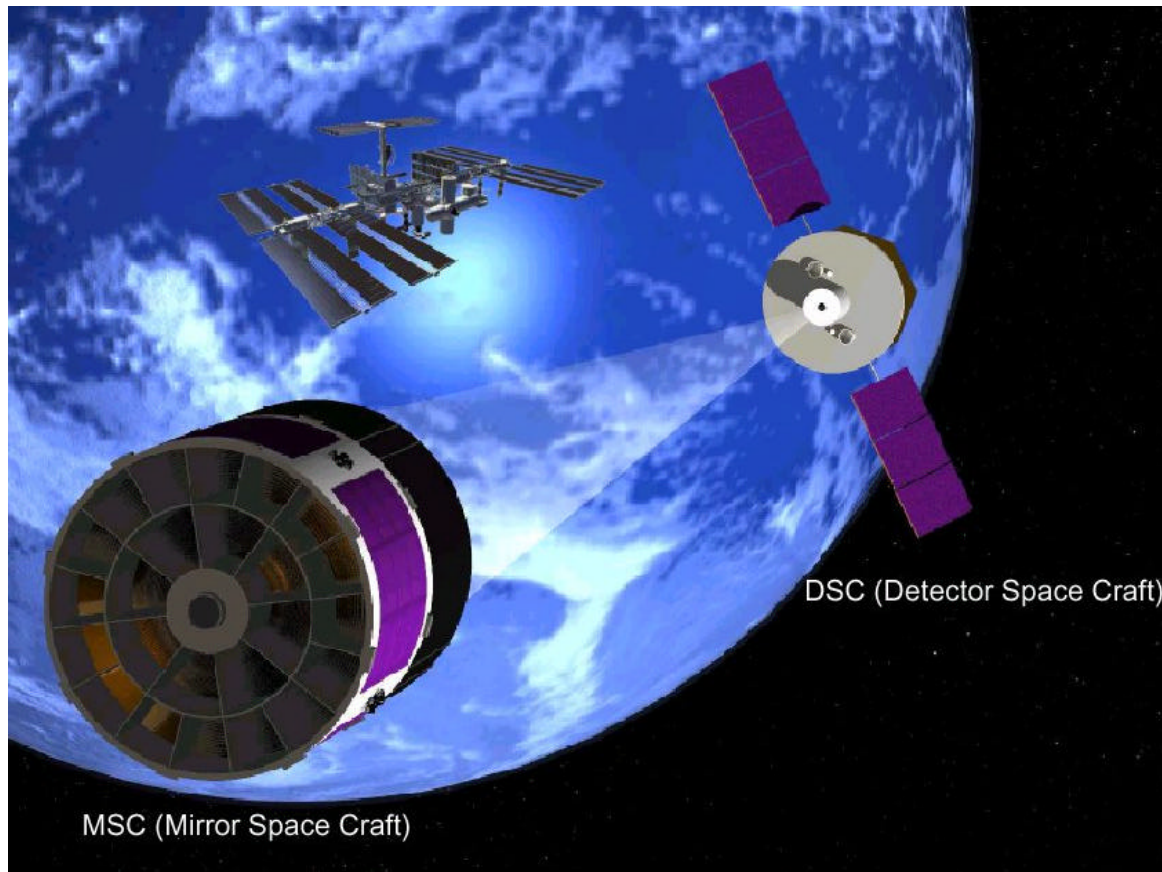

## DEPFET-Advantages:

- high rates
- no „ghost hits“
- rad hard (no transfer of signal charges necessary)
- fast partial readout of matrix areas
- multiple readout possible
- nearly no dead time

# Summary

---

- DEPFET- single pixel:
  - ENC = 6,1 e @ room temperature
- DEPFET Pixel Bioscope with 64 x 64 DEPFET Matrix:
  - Readout time for 1 image: ~ 1ms
  - spatial resolution with simple linear interpolation: ~ 9 $\mu$ m
  - noise of single image > 10 e
  - Tritium detected!
  - homogeneous charge collection efficiency!
- future: time resolved measurements, various applications

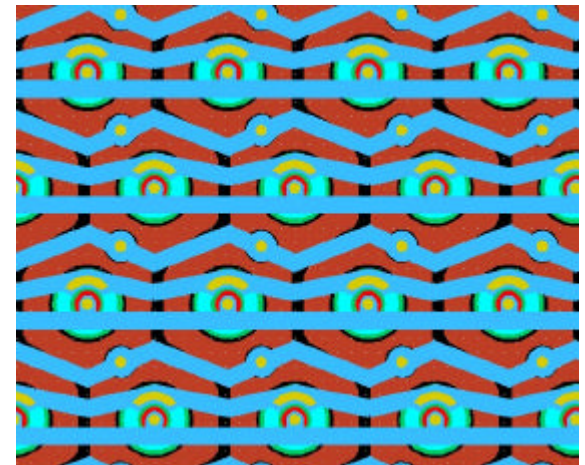

# DEPFET: Information

---

## Recent papers:

W. Neeser, M. Böcker, P. Buchholz, P. Fischer, P. Holl, J. Kemmer, P. Klein, H. Koch, M. Löcker, G. Lutz, H. Matthäy, L. Strüder, M. Trimpl, J. Ulrici, N. Wermes;  
"DEPFET - a pixel device with integrated amplification", submitted to NIM A

W. Neeser, M. Böcker, P. Buchholz, P. Fischer, P. Holl, J. Kemmer, P. Klein, H. Koch, M. Löcker, G. Lutz, H. Matthäy, L. Strüder, M. Trimpl, J. Ulrici, N. Wermes;  
"The DEPFET Pixel Bioscope", submitted to IEEE Trans. on Nucl. Sci.

P. Klein, T. Aurisch, P. Fischer, W. Neeser, L. Strüder, M. Trimpl, J. Ulrici, J. Vocht, N. Wermes;  
"A DEPFET Pixel Bioscope for the Use in Autoradiography", submitted to NIM A

## Homepage:

[depfet.physik.uni-bonn.de](http://depfet.physik.uni-bonn.de)