



Václav Vrba

Institute of Physics, Praha

Representing the ATLAS Pixel Collaboration

The ATLAS Pixel Detector Collaboration



Canada

- *University of Toronto*

Czech Republic

- *Academy of Sciences - Institute of Physics, Charles University and Czech Technical University, Prague*

France

- *CPPM, Marseille*

Germany

- *Bonn University, Dortmund University, Siegen University, Bergische University - Wuppertal, MPI Munich (R&D only)*

Italy

- *INFN and University of Genova, INFN and University of Milano, INFN and University of Udine*

Netherlands

- *NIKHEF - Amsterdam*

Taiwan

- *Academia Sinica - Taipei*

USA

- *University of New York - Albany, LBL and University of California - Berkeley, Ohio State University, Iowa University, University of New Mexico, University of Oklahoma, University of California - Santa Cruz, University of Wisconsin - Madison*

Pixel Detector Layout

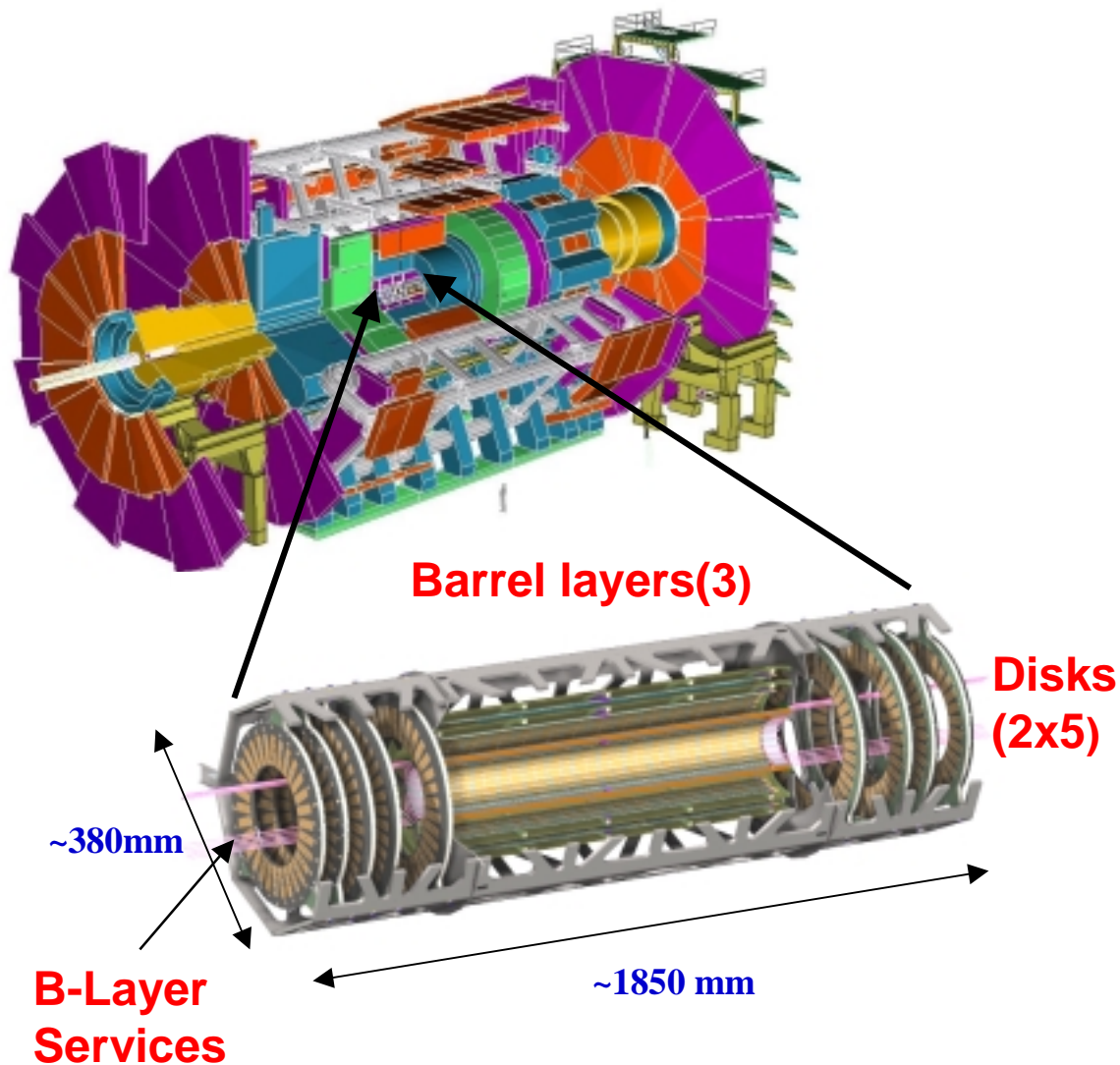

Layout:

- 3 barrel layers, 2x5 forward disks
- global support frame is made from carbon composite material; it is ultra stable and ultra light of ~ 4.4kg
- ~ 2.2 m² of active area with about 140 million pixels
- at least 3 space points for $|\eta| < 2.5$

Pixel Detector Layout – barrel part

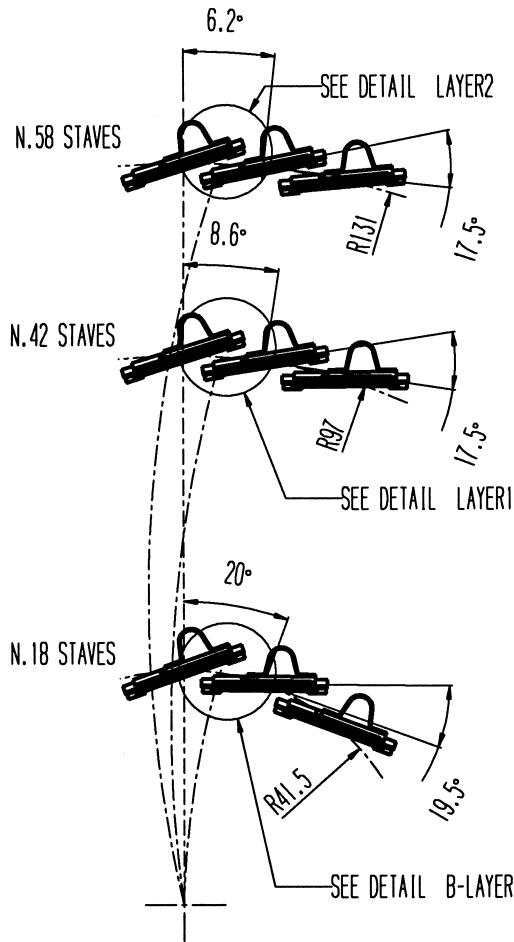

⊕ THE LAYER RADIUS LOCATION IS ON CENTRAL POINT OF ACTIVE REGION OF NON-CENTER MODULE

- 3 layers on radii approx. 13cm (2nd layer), 10cm (1st layer) and 4.5 cm (B-layer).
- The tilt angle is determined by clearance requirements and partly compensates the Lorentz angle (magnetic field 2T).
- The detector is hermetic for charged particles with p_T down to ~ 1.0 GeV/c.
- Radiation doses on the radius of the 1st layer in 10 years of LHC operation are expected to be 10^{15} 1 MeV n_{equivalent}/cm²; total dose 50 Mrad. This is the dose to which are designed individual detector components.

Pixel Detector Layout – barrel part (cont'd)

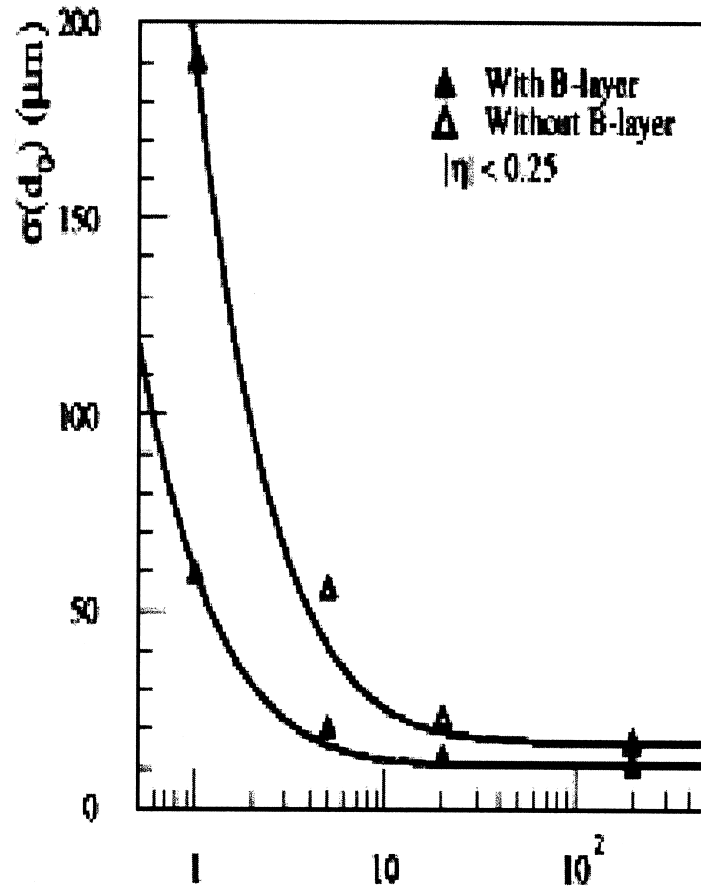

B-layer has about 5 times higher flux w.r.t. 1st layer, what has number of important consequences:

- B- layer should be replaced in approximately every 2 years;
- higher particle flux requires finer granularity; for B-layer it will be $50 \times 300 \mu\text{m}^2$ and $50 \times 400 \mu\text{m}^2$ elsewhere.

B-layer is more demanding in almost all aspects and essentially it evolved in a separate project.

Modules



Module is a basic building element of the system

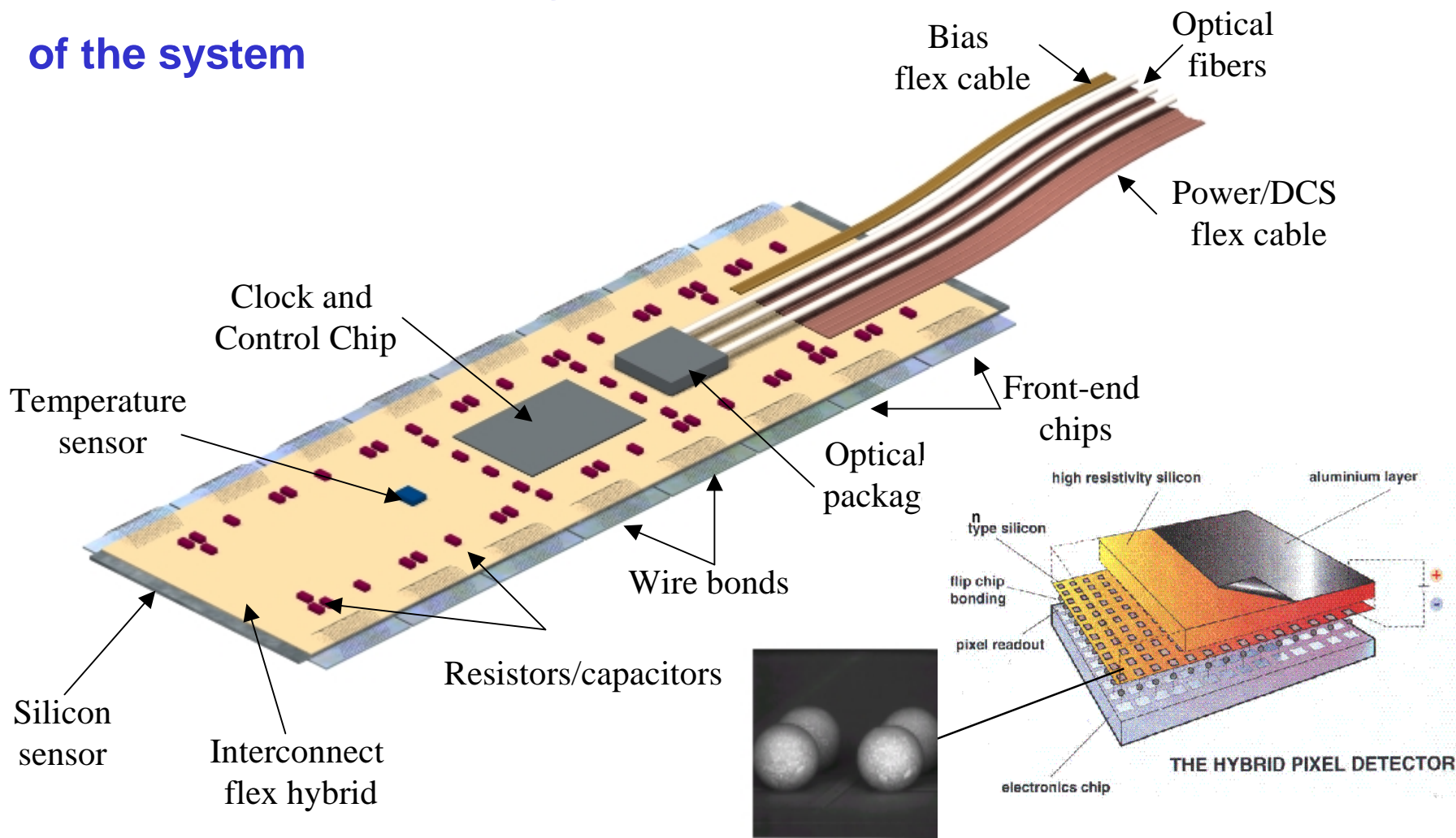

Modules (cont'd)

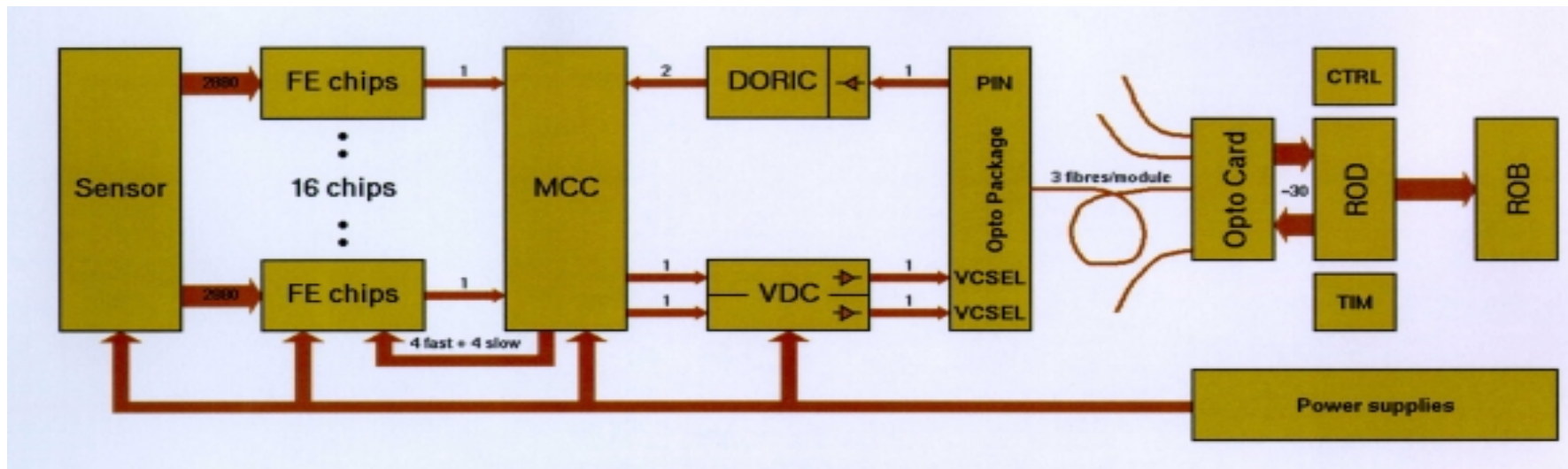

Main electronics component on module:

- FE – amplify sensor signal, send zero suppressed data on the serial link to MCC
- MCC – decode TTC protocol, control FE's, collect data, build event and send to serial link
- DORIC – amplify PIN signal, retrieve clock and data from biphas encoded optical signal
- VDC – drive VCSEL
- Supplies – provide low voltage for analog and digital parts, provide HV for sensors

ROD receives serial signals from several modules (MCC's), builds event which is then completed by ROB.

Modules (cont'd)



Flex hybrid solution (*special talk by P.Skubic on this conf.*) is a baseline for all the detector but B-layer.

For the B-layer the MCM-D technique was adopted as a baseline (*special talk by C.Grah on this conf.*).

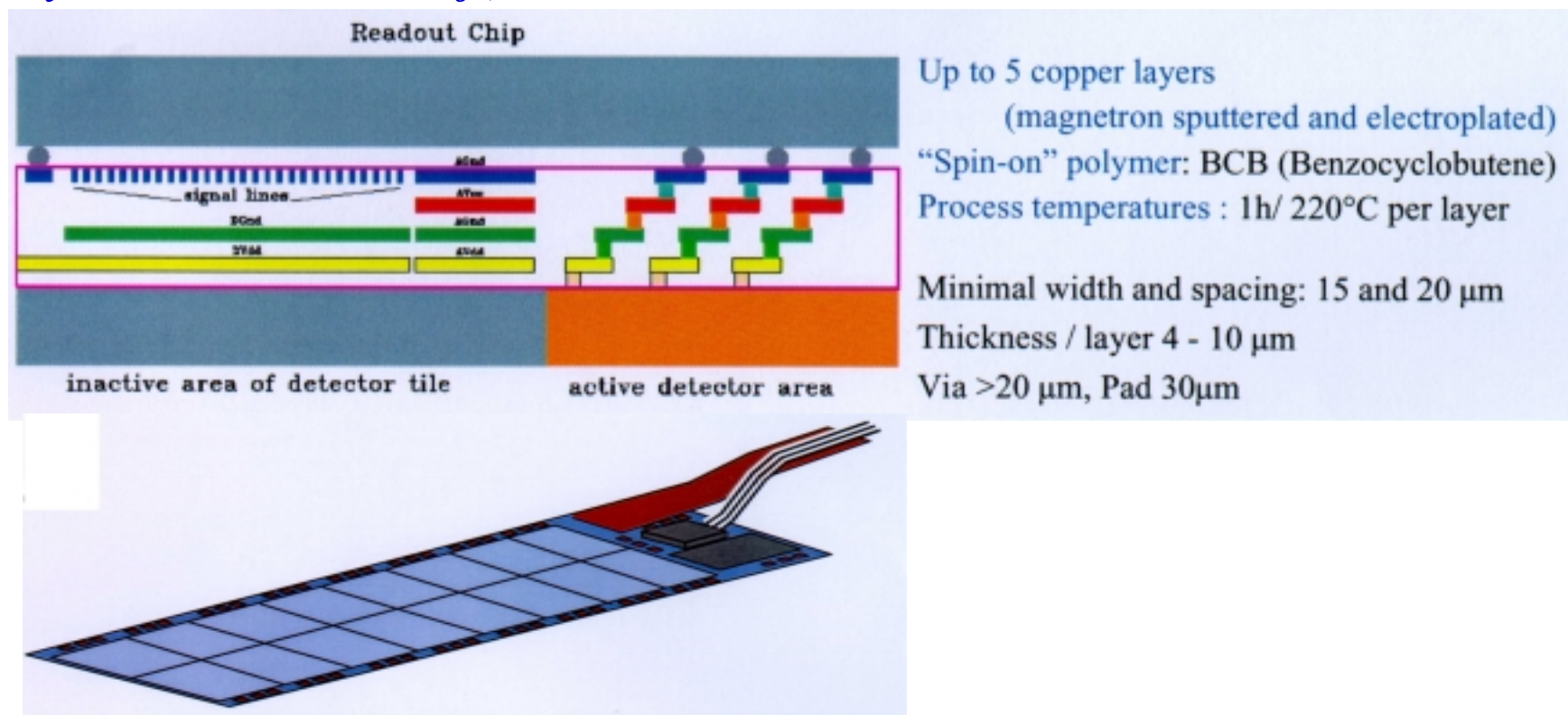

- At fluencies $\sim 1 \times 10^{14}$ n-type silicon of resistivity few $\text{k}\Omega \cdot \text{cm}$ changes the type. To have possibility to work with partially depleted sensor the ATLAS Pixel Collaboration decided to use **n+n concept** for the sensor design.
- To keep low the material budget the thickness of sensor is used as low as practical: $250 \mu\text{m}$ for the 1st and 2nd layer and rings, $200 \mu\text{m}$ for the B-layer.
- Different isolation techniques have been evaluated:

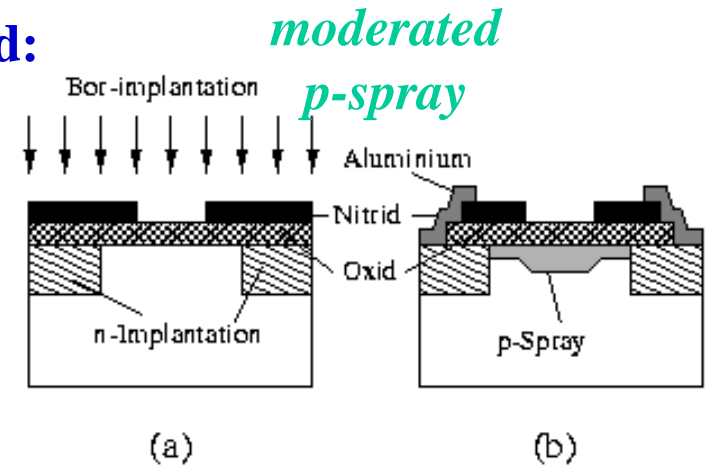
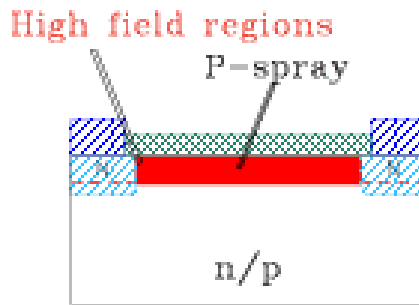
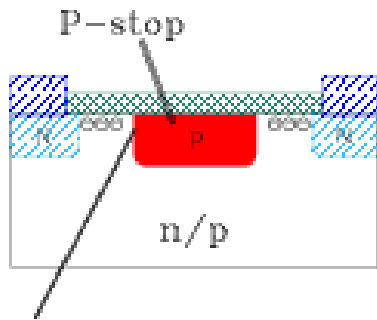

High field regions
before irr. : *low E-field*

high E-field

low E-field

after irr. : *high E-field*

low E-field

low E-field

- The results from prototypes (1.0, 1.5, 1.5b and 2.0) have shown that sensors with moderated p-spray irradiated by 10^{15} n/cm² can operate at $V_{\text{bias}}=600\text{V}$, what is by factor of two higher than e.g. break down voltage with p-stop isolation for the similar pixel design.
- Important for the pre-assembly sensor testing is to have bias grid, several variants have been tested; the best results have been obtained with the so called SSGb design as below:

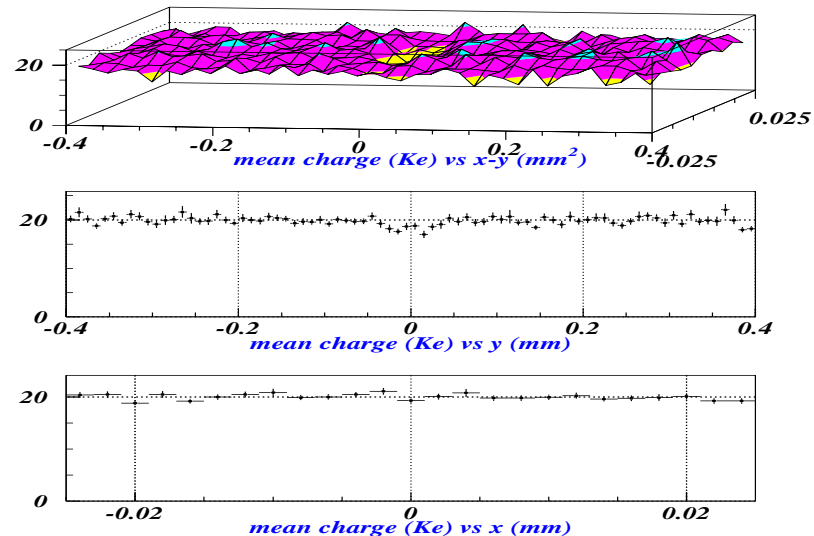
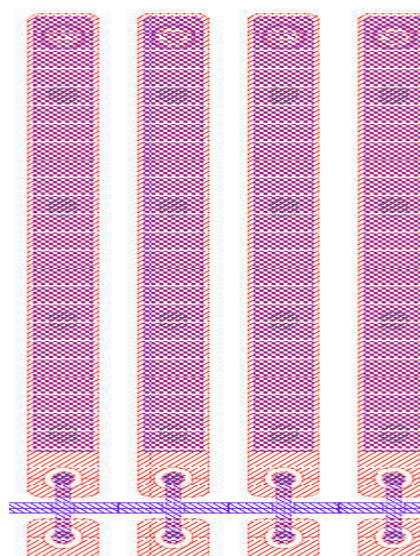

Sensors (cont'd)



- Such sensors have high and uniform charge collection efficiency over 99%.
- They are sufficiently radiation resistant; at $V_{\text{bias}} = 600\text{V}$ the depleted region is nearly $200\ \mu\text{m}$ and providing signal about $9\ \text{ke}^-$.
- The resolution is as expected (about $12\ \mu\text{m}$ in R*Phi for perpendicular tracks) for not irradiated sensors and does not significantly deteriorate with irradiation.

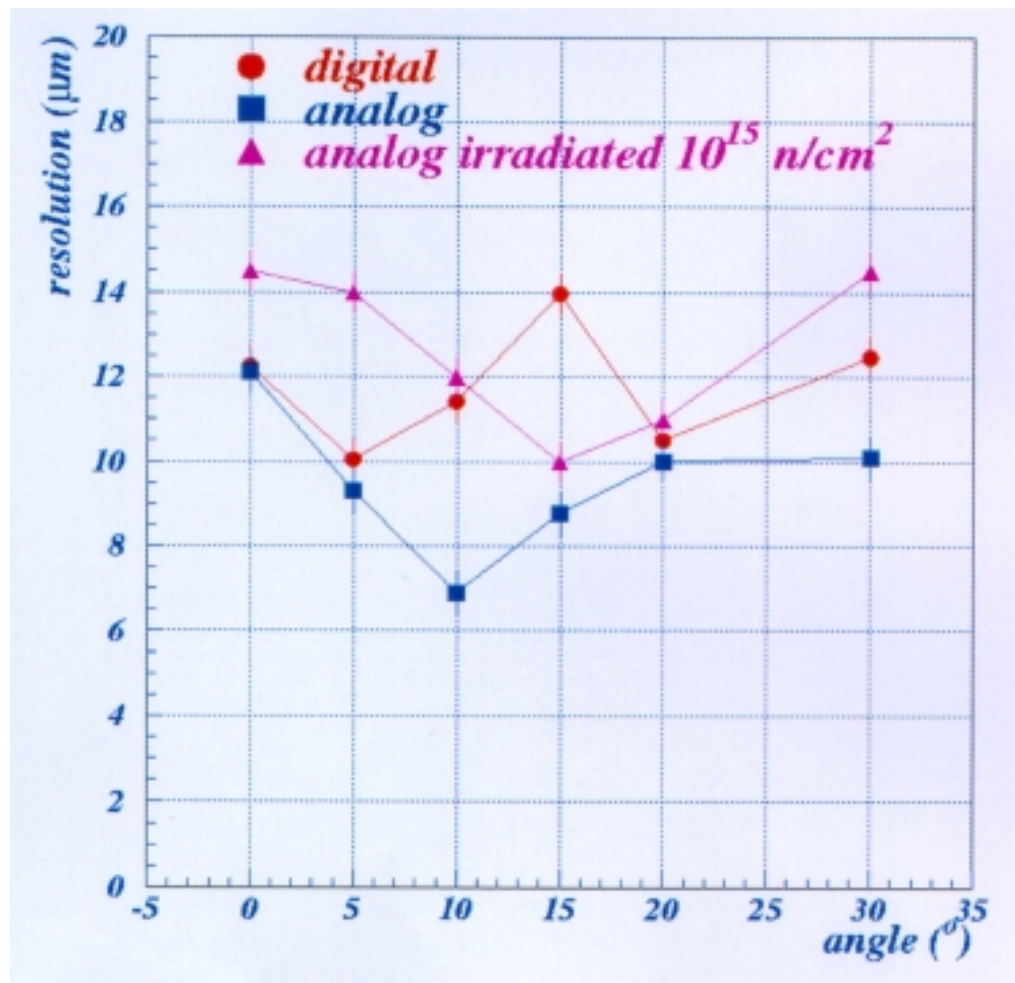

According the results of RD48 (Rose) collaboration a factor of two for the depletion voltage it is possible to gain using oxygen enriched silicon. Such material will be used for production.

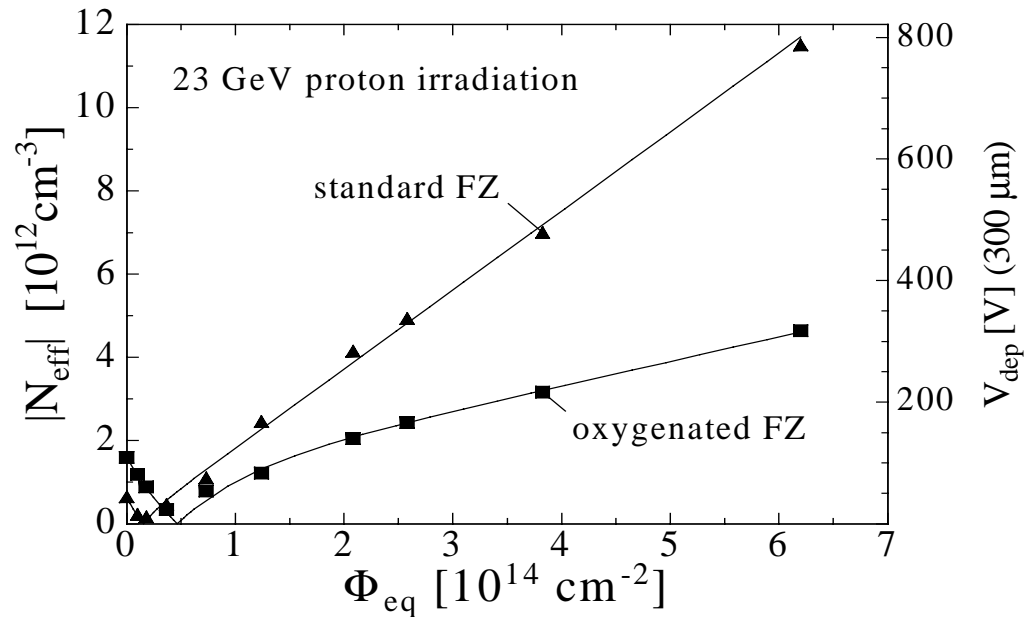

- Sensor project entered in the pre-production stage:
- *FDR (3rd Dec.1999) and PRR (2nd Feb. 2000)*
- *Currently the tendering procedure is in process. The pre-production will start in Summer 2000; mass production in the beginning of 2001.*
- *Program of testing, quality assurance program → other talks at this conference.*

- FE electronics represents most complicated part of the system.
- It should properly operate after total dose of about 50 MRad and also cope with expected leakage current from sensors of up to 50 nA per pixel.
- Operate with low noise occupancy (below 10^{-6} hits/pixel/crossing), at threshold of about $3ke^-$ with good enough time-walk to have “in-time” threshold of about $4ke^-$. This requires a small threshold dispersion and low noise, both about $200e^-$.
- Several generations of prototypes have been built as “proof of principles” which resulted in a final design.

Main features of the analog cell:

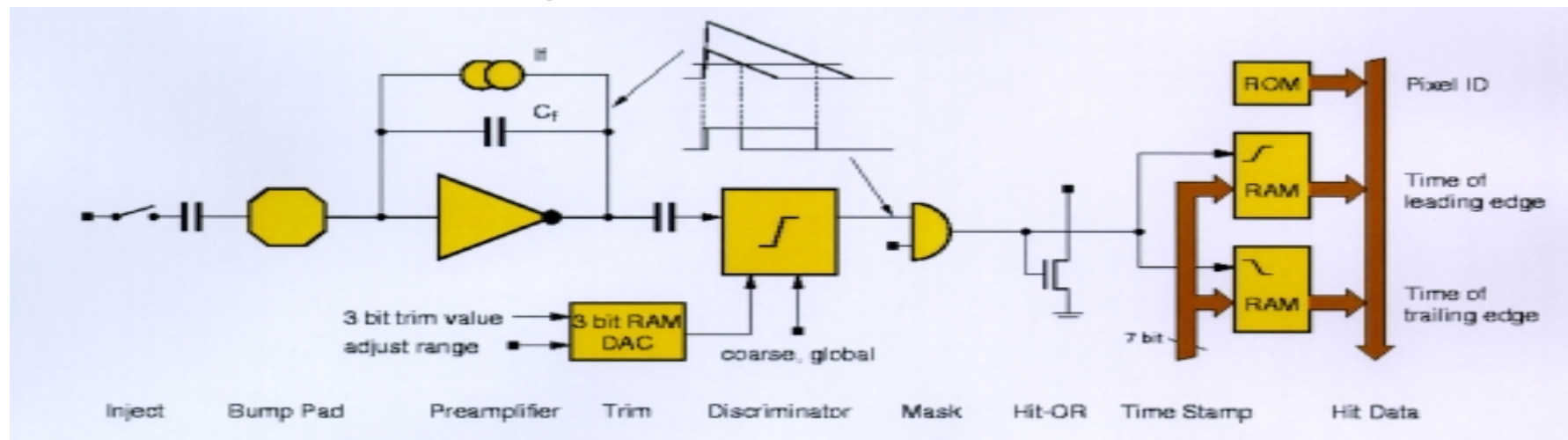

- Fast charge preamplifier with current feedback.
- Discriminator is AC coupled and includes 3-bit trim DAC for threshold equalization.
- Pulse height measurement via Time-over-Threshold measurement – 7 bits.

- Asynchronous data push architecture used to get data into buffers at the bottom of the chip, where they are stored for L1 latency; after that they are flagged for readout or deleted. Chip transmits Trigger/Row/Column/ToT for each hit.
- Preamplifier output is on figures below for different injected charges and different feedback currents, resp.:

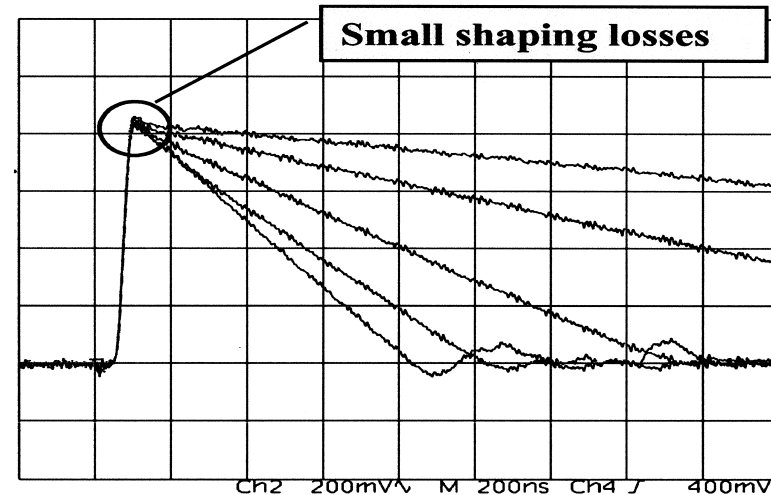
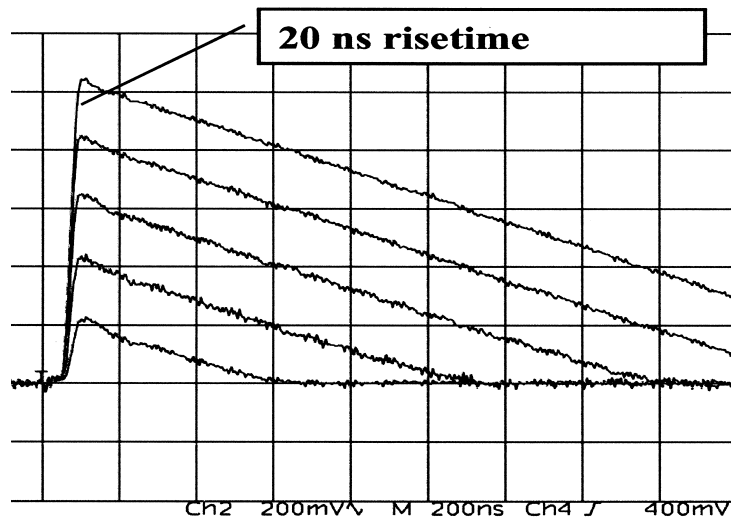

FE electronics (cont'd)



- Presently big effort to have rad-hard version of FE-D TEMIC/DMILL,
FE-H Honeywell.
- More by P.Fisher on this conf.

Work in Progress

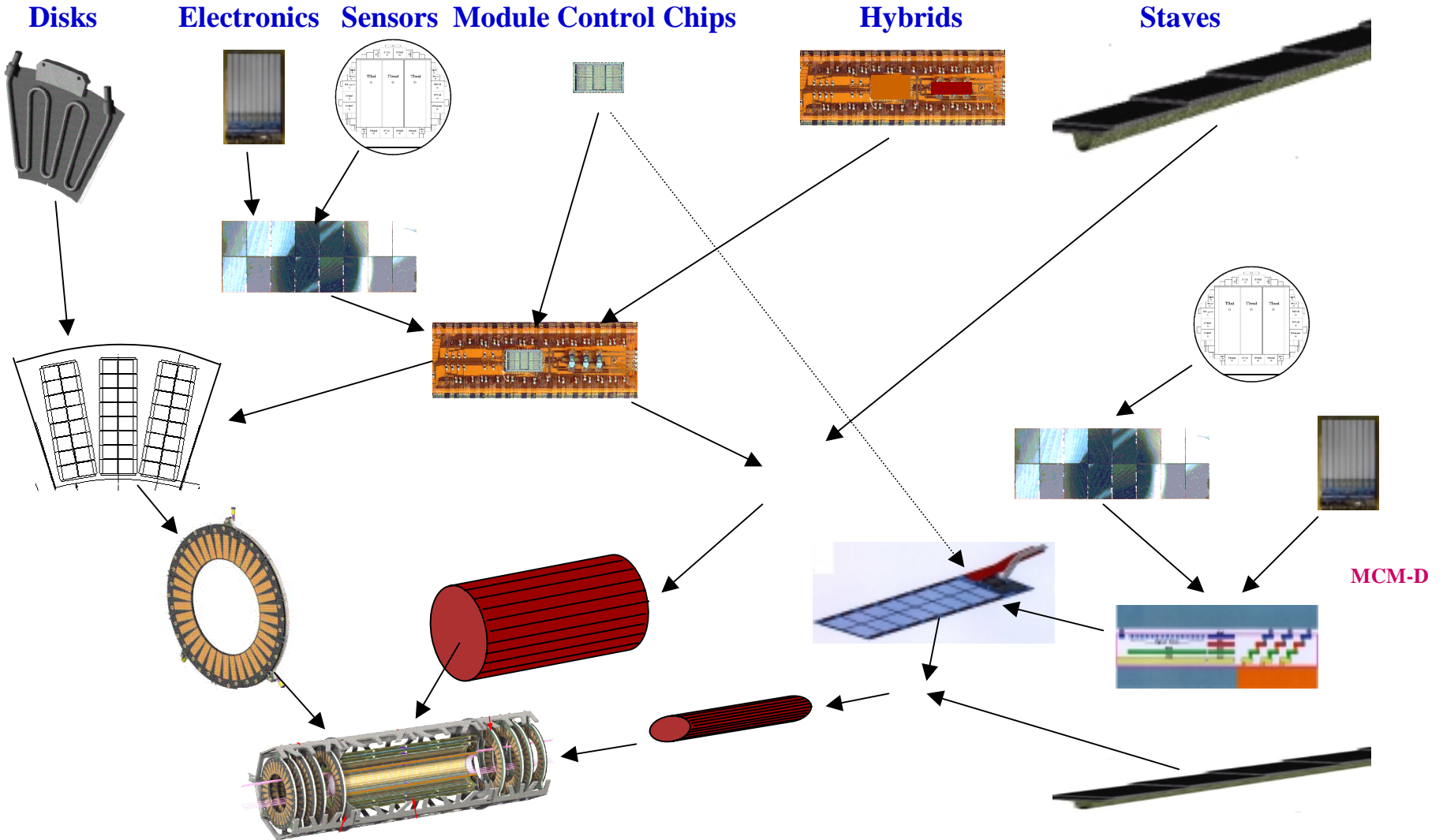

Material budget

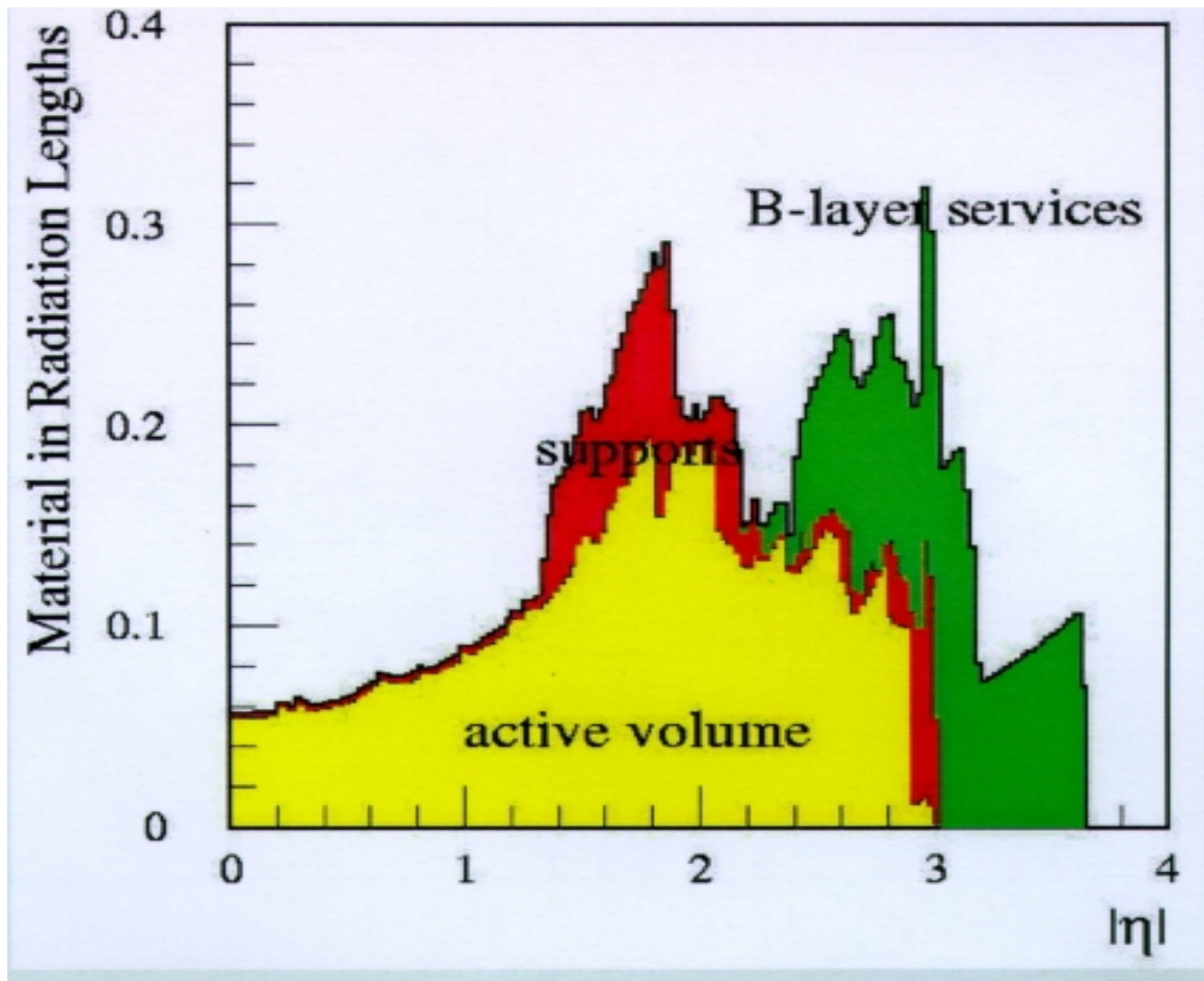

Conclusions



- **The ATLAS Pixel Collaboration is approaching to the pre-production and production phase.**
- **RD phase for sensors have been accomplished with radiation tolerant sensor design fulfilling all major requirements.**
- **Transfer rad-soft version to the rad-resistant version is on going.**
- **Many other topics will be discussed in dedicated contributions.**