

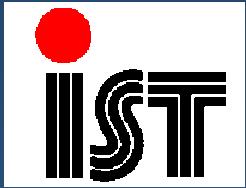

Geant 4

HEP software & the GRID A breakthrough in the fight against cancer

<http://www.ge.infn.it/geant4/examples/brachytherapy>



F. Foppiano, S. Guatelli, J. Moscicki, M.G. Pia

CERN

INFN Genova

National Institute for Cancer Research, IST Genova



CHEP 2003, San Diego (CA), 24-28 March 2003

A real-life case

but all the results presented in this talk are general

- Activity initiated at IST Genova, Natl. Inst. for Cancer Research (*F. Foppiano et al.*)
 - hosted at San Martino Hospital in Genova (the largest hospital in Europe)
- Collaboration with San Paolo Hospital, Savona (*G. Ghiso et al.*)
 - a small hospital in a small town

Major work by **Susanna Guatelli**

MSc. Thesis, Physics Dept., University of Genova, 2002

<http://www.ge.infn.it/geant4/tesi/>

Brachytherapy

Brachytherapy is a medical therapy used for cancer treatment

Radioactive sources are used to deposit therapeutic doses near tumors, while preserving surrounding healthy tissues

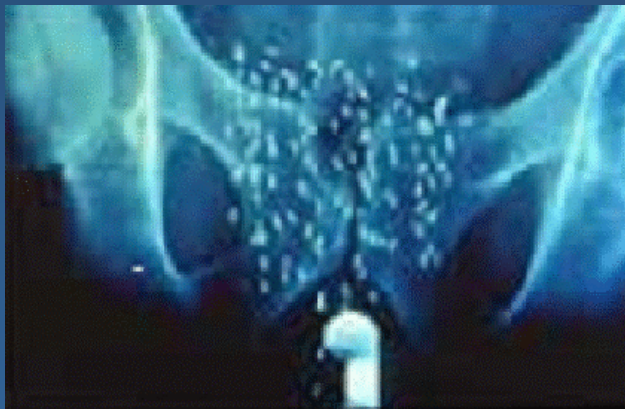

Techniques:

- endocavitary
 - lung, vagina, uterus
- interstitial
 - prostate
- superficial
 - skin

Radiotherapy treatment planning

- Treatment planning is performed by means of commercial software
- The software calculates the dose distribution delivered to the patient in a given source configuration

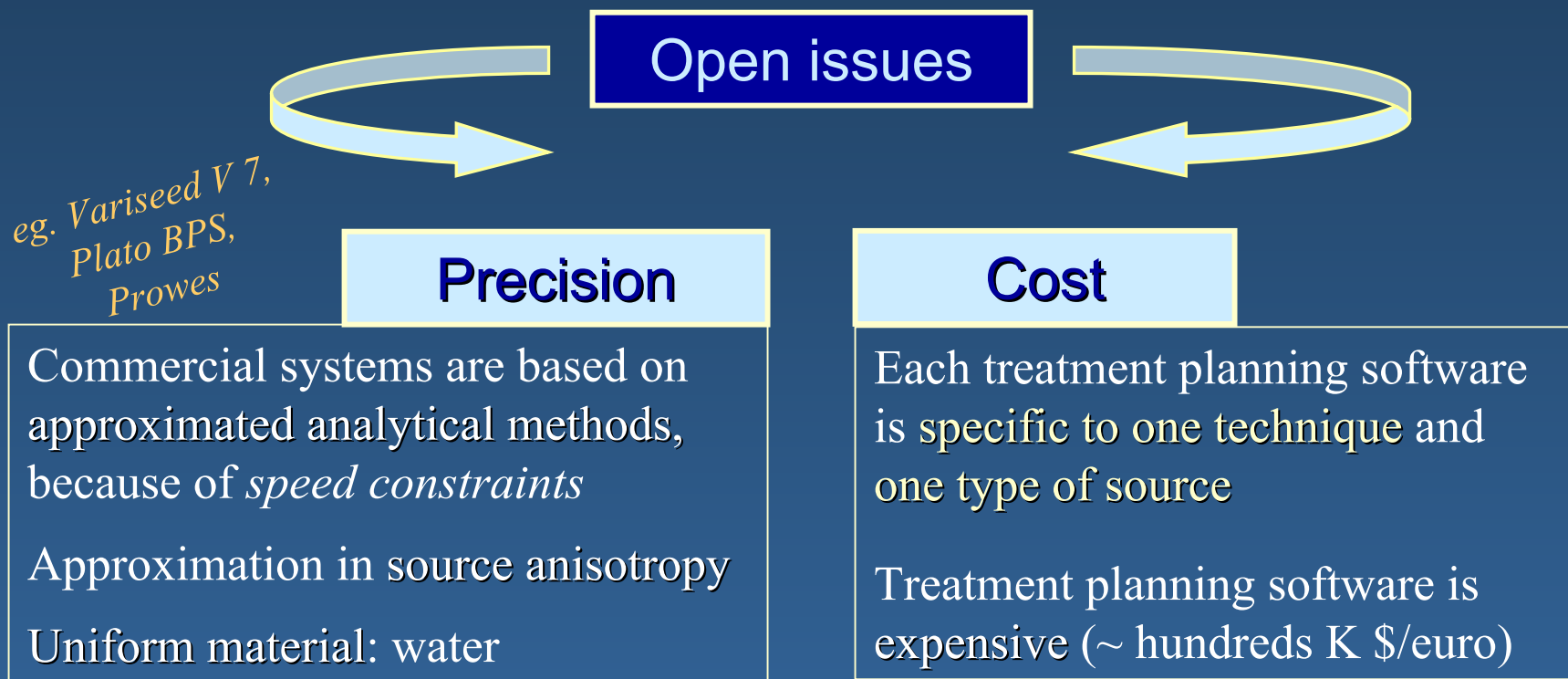

A dosimetric system for brachytherapy

Calculation of 3-D dose distribution in tissue
Determination of **isodose curves**

Geant 4

AIDA
Anaphe

DIANE

ID

www

Precision



Based on Monte Carlo methods
Accurate description of physics interactions
Experimental validation of physics involved

Accurate model of the real set-up



Realistic description of geometry and tissue
Possibility to interface to CT images

Easy configuration for hospital usage



Graphic visualisation + User Interface
Elaboration of dose distributions and isodoses

Speed



Parallelisation
Access to distributed computing resources

Other requirements



Open to extension and new functionality
Publicly accessible

Modeling the radioactive source

Plato-BPS treatment planning algorithm makes some crude approximation (ϕ dependence, no radial dependence)

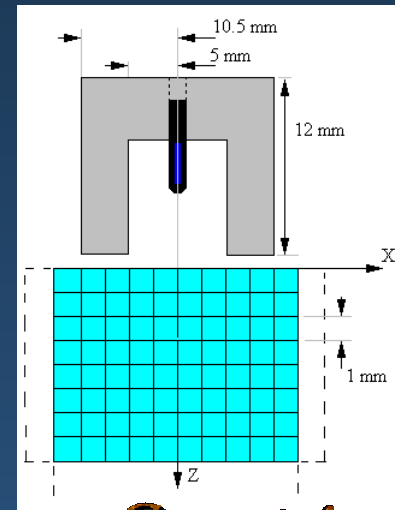
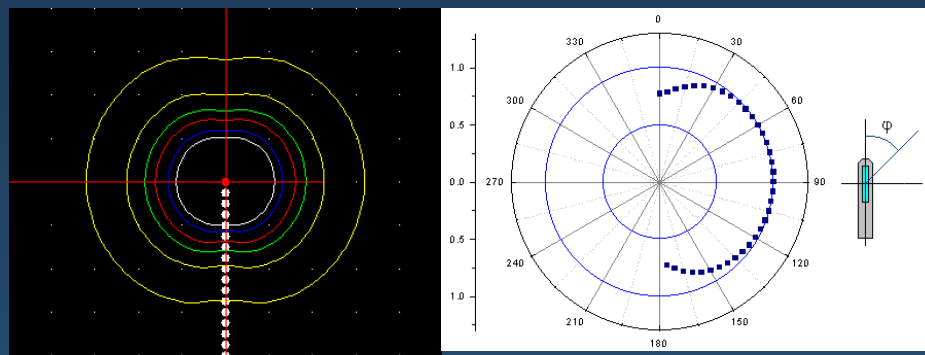

Transverse axis of the source
Comparison with experimental data

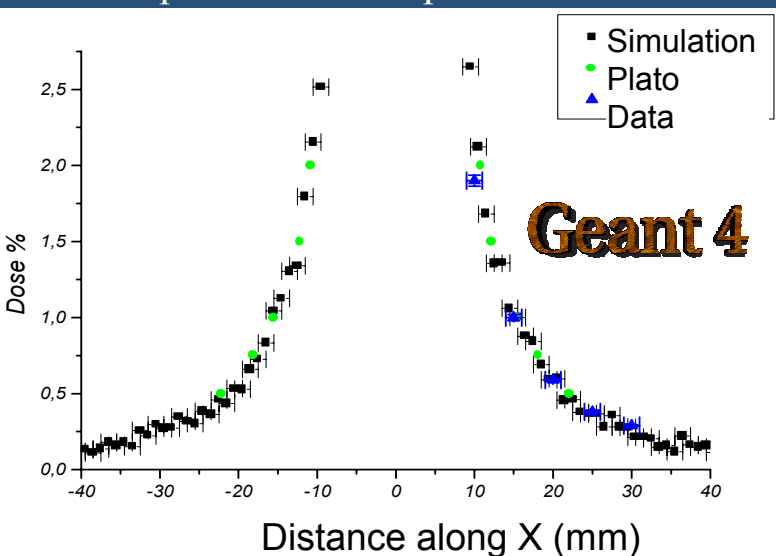

Longitudinal axis of the source
Difficult to make direct measurements

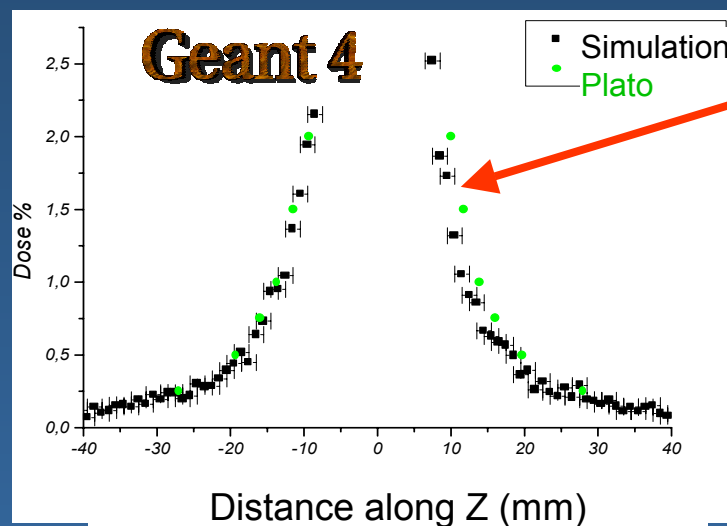

Effects of source anisotropy

Rely on simulation for better accuracy than conventional treatment planning software

Validation

Microscopic validation: verification of Geant4 physics

Dosimetric validation: comparison to manufacturer data, protocol data, original experimental data

X-ray Attenuation Coefficients - Water

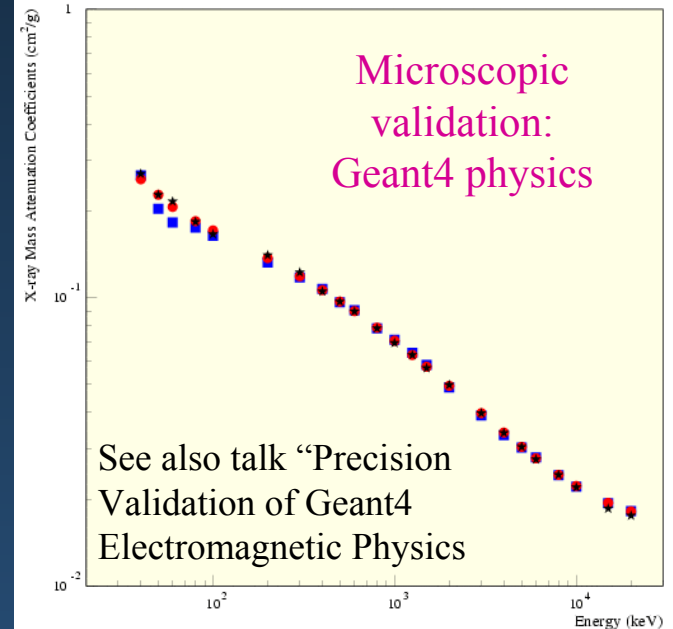

S. Guatelli et al., Savona Hospital

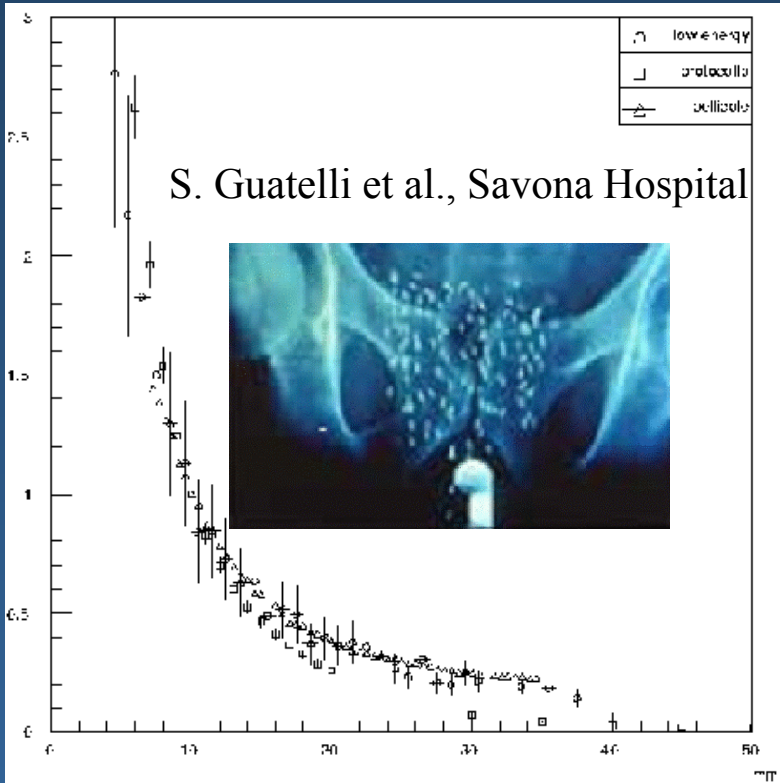

Maria Grazia Pia, INFN Genova

F. Foppiano et al., IST Genova

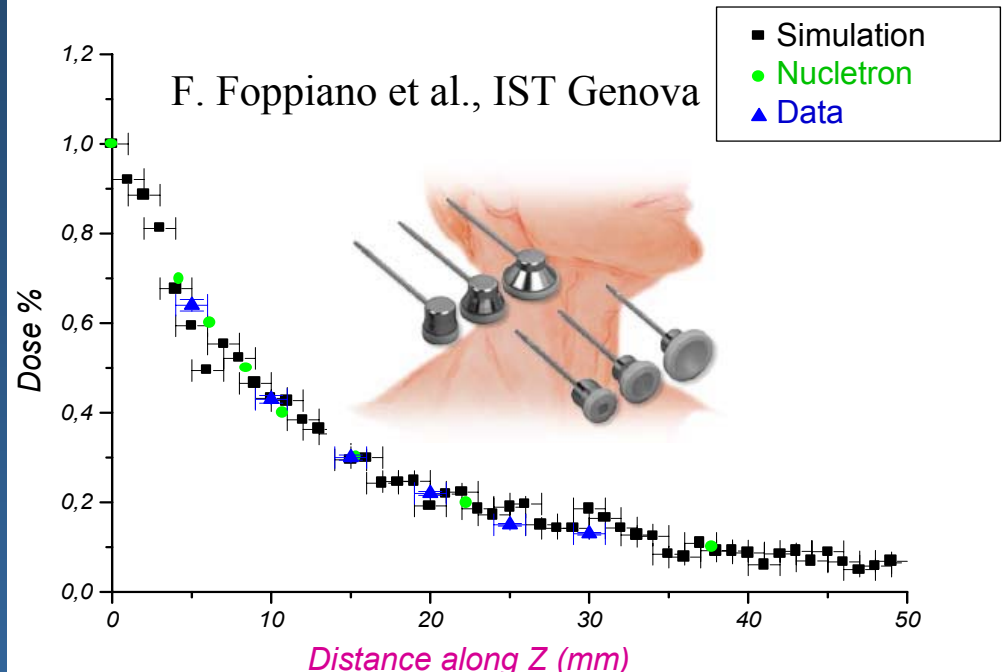

Flexibility of modeling

Configuration of

- any brachytherapy technique
- any source type

through an Abstract Factory
to define geometry, primary spectrum

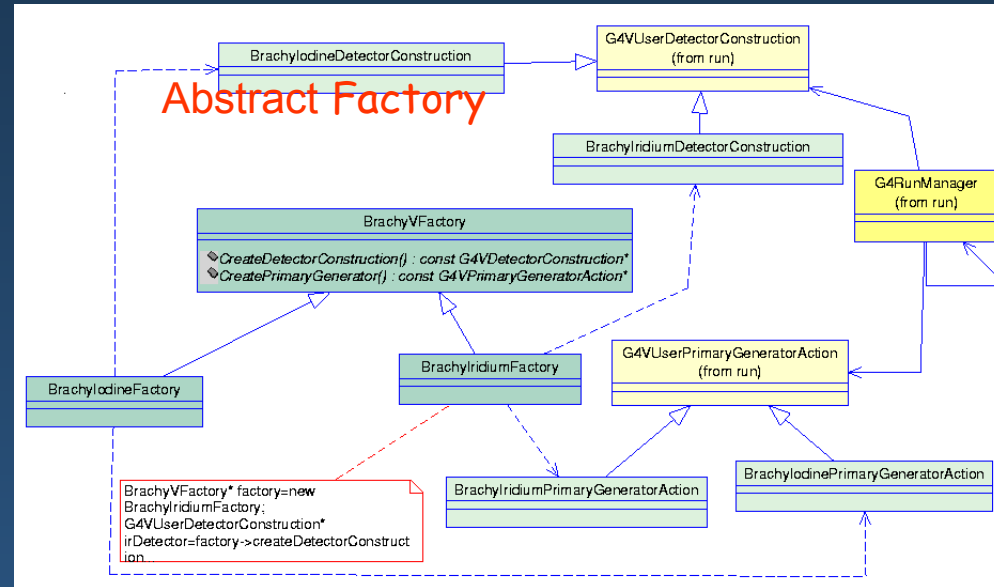

CT DICOM interface

- through Geant4 parameterised volumes
 - parameterisation function: material
- (preliminary, work in progress)

Phantom

- various materials
- water, soft tissue, bone, muscle etc.*

No commercial general software system!

Application configuration

File Edit View Go Communicator Help

Back Forward Reload Home Search Netscape Print Security Shop Stop

Bookmarks Location: <http://guatelli.home.cern.ch/guatelli/brachy-diane/simulation.html> What's Related

Red Hat Network Support Shop Products Training

2. Running the simulation

In order to run your simulation:
fix the simulation parameters,
the number of events of the run.

Then press **BeamOn**.

The **result** of the simulation is the dose distribution in the plane containing the source.

2.1 Choose the simulation parameters

2.2.1 Choose the radioactive source

Available radioactive sources: I-125, Ir-192, Leipzig

I-125

2.2.2 Choose the phantom absorber material

Available materials: water, soft_tissue, air

water

2.2.3 Choose the number of gamma delivered by the source

1000

2.2.4 Press beamOn to run the simulation

BeamOn

2.2.5 Back again to the simulation default parameters if you like !

Reset

100%

Fully configurable
from the web

Run modes:

- demo
- parallel on a cluster
- on the GRID (*in preparation*)

Simple, friendly user
interface for hospital usage
even by non-specialists

Dosimetry

Analysis of the energy deposit in the phantom resulting from the simulation

Dose distribution

Isodose curves

AIDA + Anaphe

for analysis

Python

for interactivity

*may be any other
AIDA-compliant
analysis system*

Bebig Isoseed I-125 source

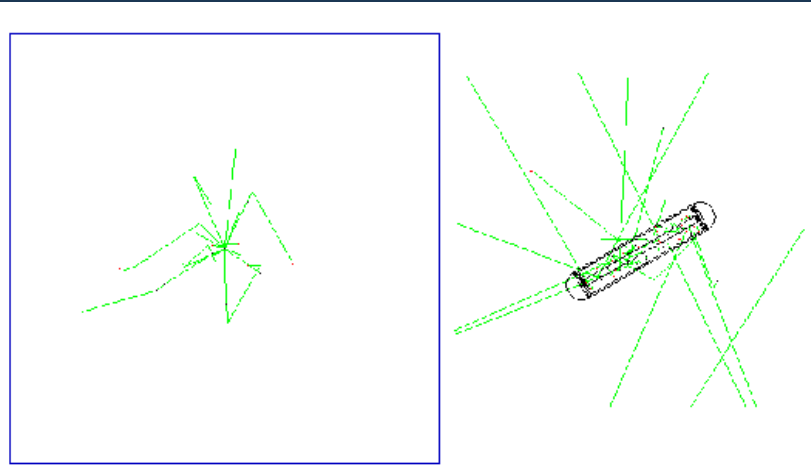

Dosimetry Interstitial brachytherapy

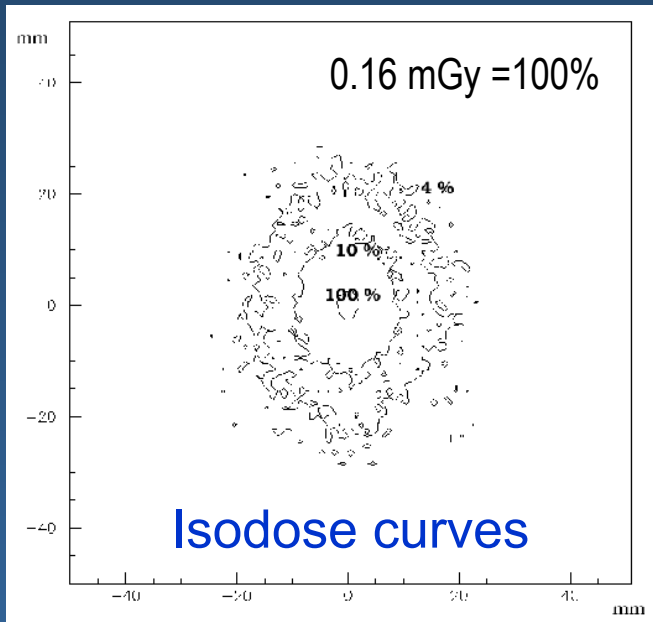
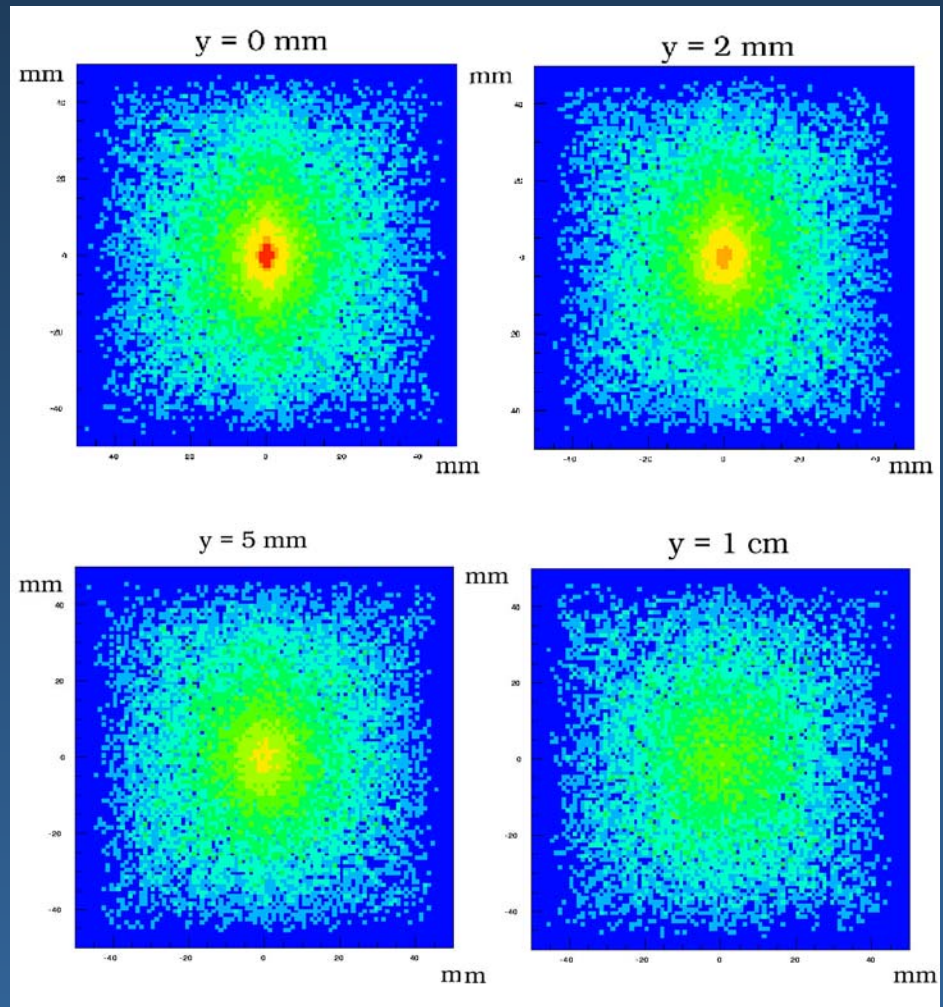

Dosimetry

Endocavitary brachytherapy

MicroSelectron-HDR source

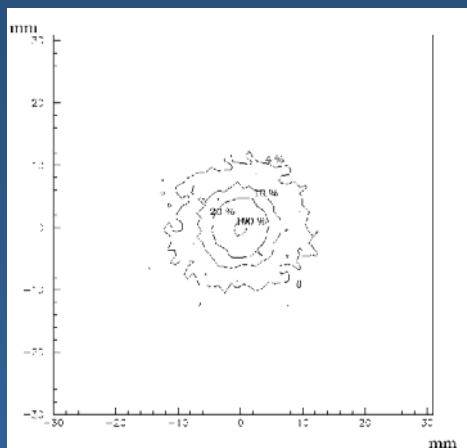
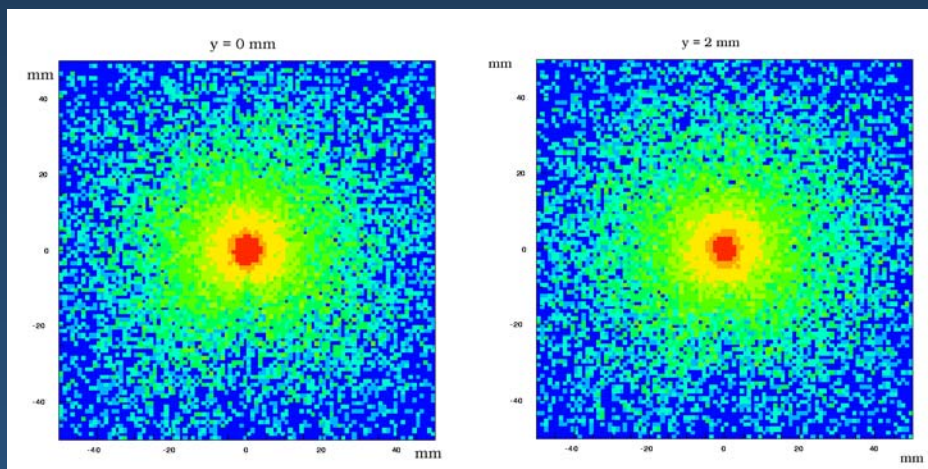

Dosimetry

Superficial brachytherapy

Leipzig applicator

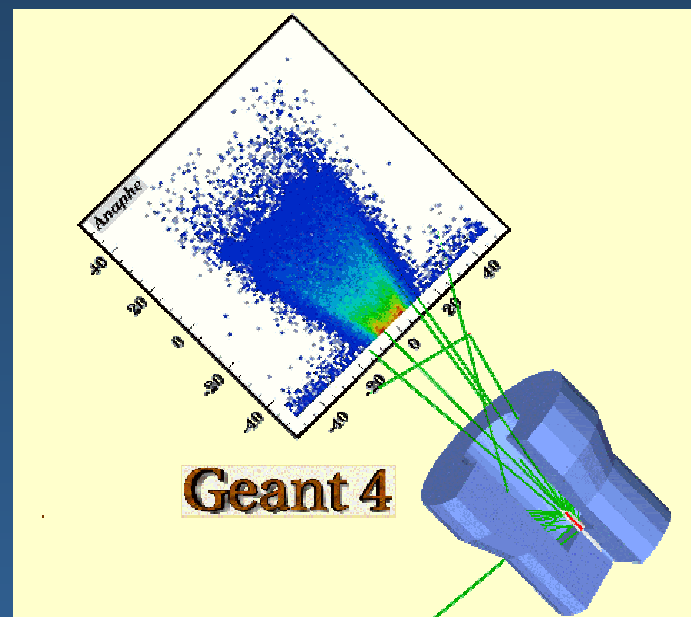

Performance

**Endocavitary
brachytherapy**

1M events
61 minutes

**Superficial
brachytherapy**

1M events
65 minutes

**Interstitial
brachytherapy**

1M events
67 minutes

on an “average” PIII machine, as an “average” hospital may own

**Monte Carlo simulation is not practically conceivable for
clinical application, even if more precise**

Access to distributed computing

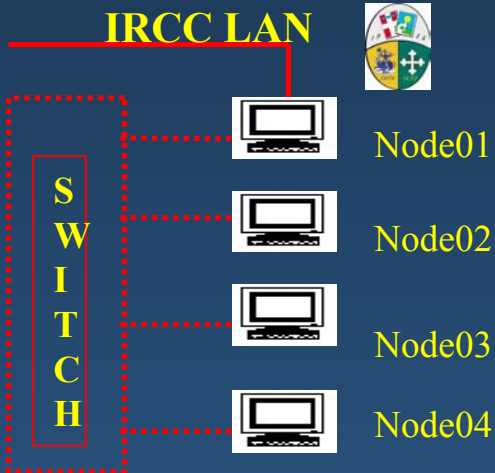

Previous studies for parallelisation of a Geant4 based medical application

- speed OK
- but expensive hardware investment + maintenance

Alternative strategy



DIANE

Transparent access
to a distributed computing environment

Parallelisation

Access to the GRID

DIANE Distributed Analysis Environment

hide complex details of underlying technology

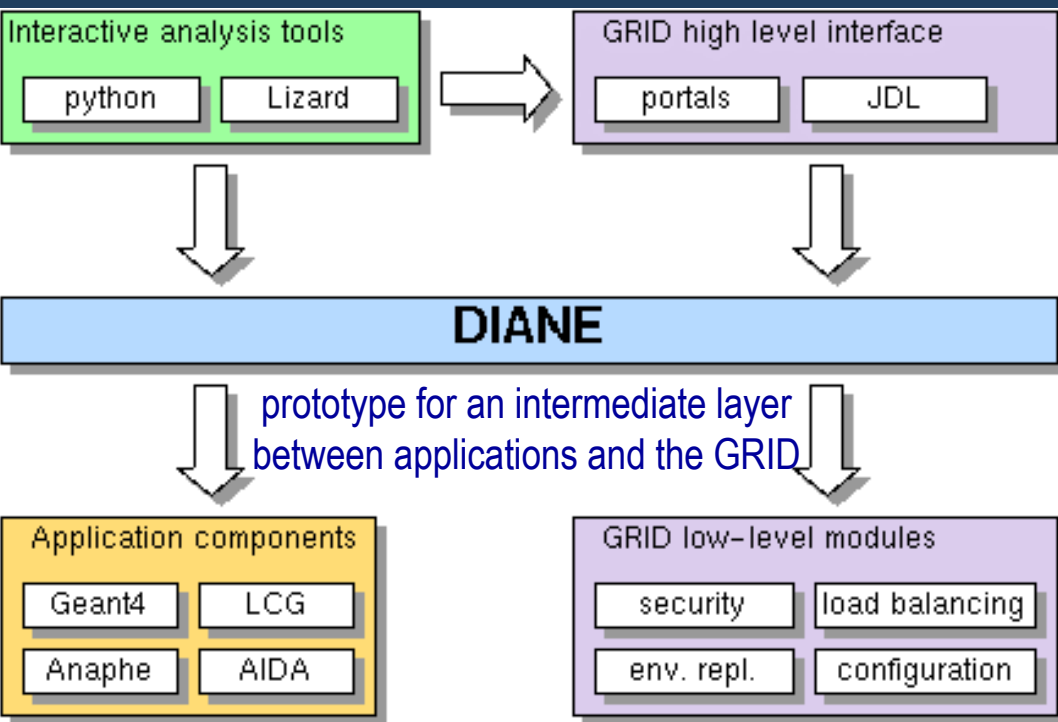

Parallel cluster processing

- make fine tuning and customisation easy
- transparently using GRID technology
- application independent

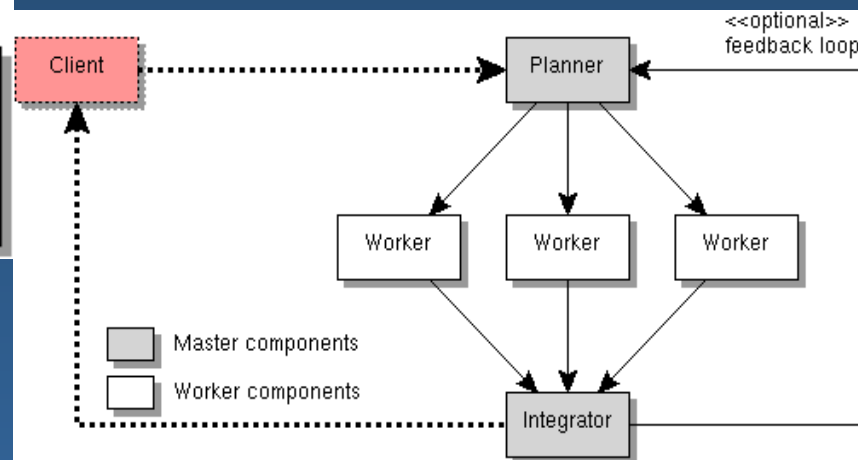

See talk by J. Moscicki, Session 1
“DIANE: distributed analysis environment”

Migration to distributed environment

- The application developer (*e.g. Geant4 simulation + analysis*) is shielded from complexity of underlying technology
- Not affecting the original code of application
 - standalone and distributed cases is the **same code**
- Good separation of the subsystems
 - application does not need to know that it runs in distributed environment...
 - the distributed framework (DIANE) does not need to care about what actions application performs internally

Performance: parallel mode

**Endocavitary
brachytherapy**

1M events
4 minutes 34''

**Superficial
brachytherapy**

1M events
4 minutes 25''

**Interstitial
brachytherapy**

5M events
4 minutes 36''

preliminary
further optimisation
in progress

on up to 50 workers, LSF at CERN, PIII machine, 500-1000 MHz

Performance is adequate for clinical application, but...

it is not realistic to expect any hospital to own and maintain a PC farm

Running on the GRID

- Via DIANE
- Same application code as running on a sequential machine or on a dedicated cluster
 - completely transparent to the user
- Consequence
 - a hospital is not required to own and maintain extensive computing resources to exploit the scientific advantages of Monte Carlo simulation for radiotherapy
 - any hospital – even small ones, or in less wealthy countries, that cannot afford expensive commercial software systems – may have access to advanced software technologies and tools for radiotherapy
- Work in progress: submission to the GRID and retrieval of results from a web portal
 - to facilitate the usage by end-users

Outlook: other radiotherapeutic techniques

Radiotherapy with extracted beams

M.C. Lopes, L. Peralta,
P. Rodrigues, A. Trindade
IPOFG-CROC Coimbra
Oncological Regional
Center, LIP - Lisbon

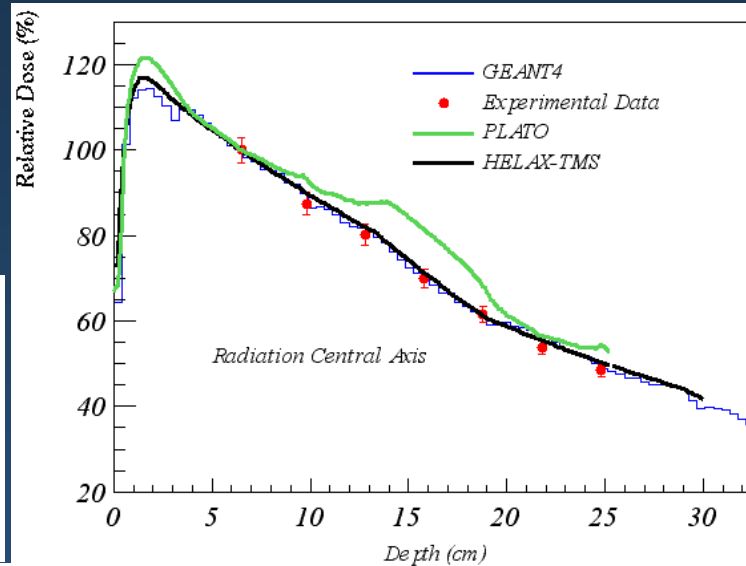

Hadrontherapy

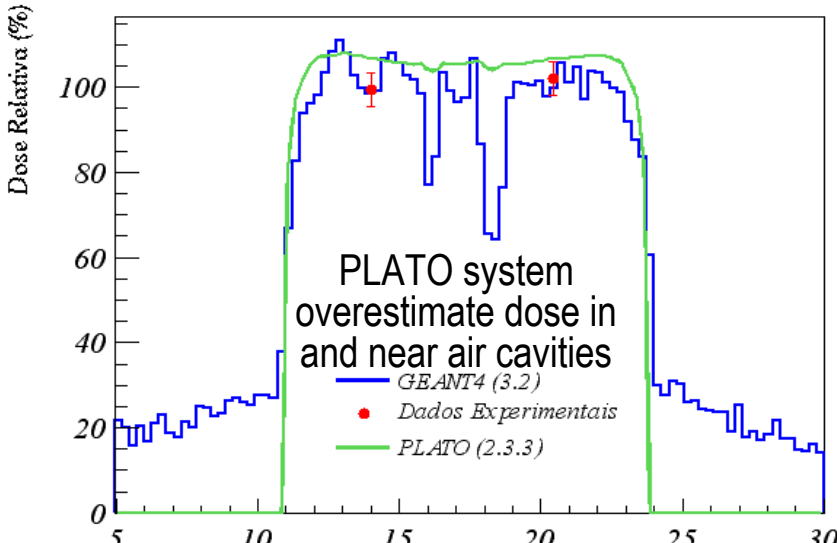
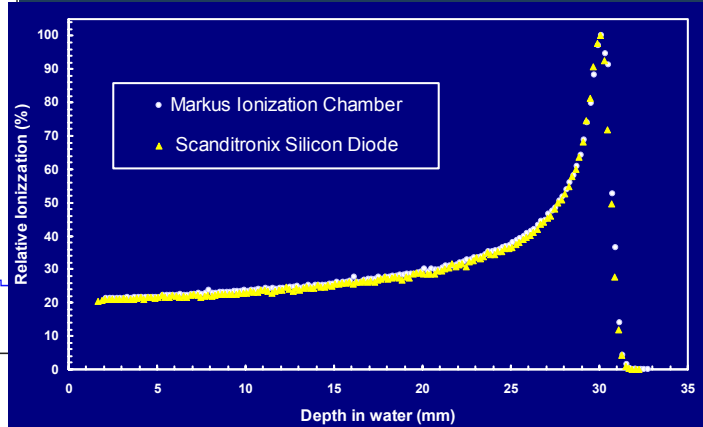

Effect of bone structures on dose are present in GEANT4 and absent in PLATO

Treatment planning systems for hadrontherapy are quite primitive
Not commercially convenient so far...

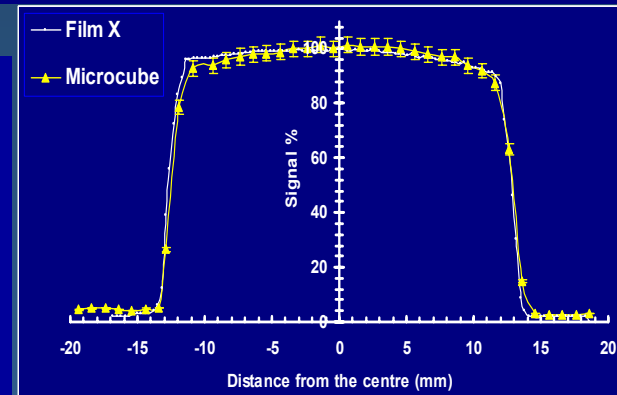

In some tumours sites (ex: larynx T2/T3-stage) a 5% underdosage will decrease local tumour control probability from ~75% to ~50%

Conclusions

- A precise dosimetric system, based on Monte Carlo simulation
 - Geant4
- Full dosimetric analysis
 - AIDA + Anaphe
- Simple interface
 - configuration from www
- Fast performance
 - DIANE
- Access to distributed computing resources
 - GRID

- The dream of medical physics for the past 40 years...

Post-conclusion

Medical physics does not only require fast simulation and fancy analysis...

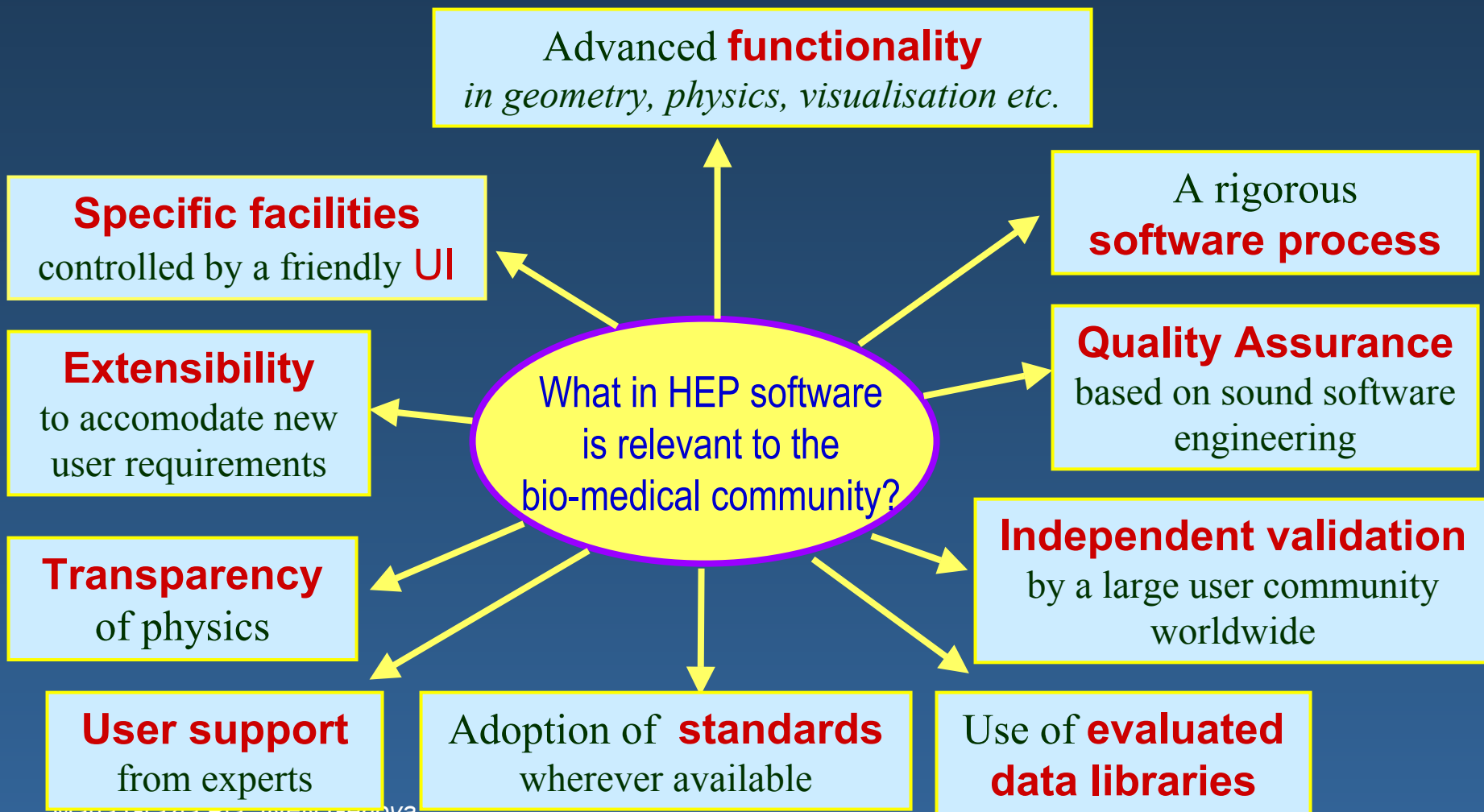

Thanks!

- G. Cosmo, V. Ivanchenko (*Geant4*)
- L. Moneta, I. Papadopoulos, A. Pfeiffer, M. Sang (*Anaphe*)
- J. Knobloch (*CERN*)
- A. Mantero (*Univ. of Genova*)
- S. Agostinelli, S. Garelli (*IST Genova*)
- G. Ghiso, R. Martinelli (*S. Paolo Hospital, Savona*)
- S. Chauvie (*INFN Torino and IRCC*)
- G.A.P. Cirrone, G. Cuttone (*INFN LNS, CATANA project*)
- M.C. Lopes, L. Peralta, P. Rodrigues, A. Trindade (*LIP Lisbon*)