



Geant 4

entro i limiti dei
30' disponibili!

per LHC
...e non solo per LHC

Maria Grazia Pia, INFN Genova
in rappresentanza del gruppo Geant4-INFN
e della Collaborazione Geant4

<http://www.ge.infn.it/geant4/>

Commissione I
Roma, 12 maggio 2003

Outline

- **The requirements process**
 - how requirements (from LHC experiments and from other user groups) are elicited, specified, analysed, accepted, prioritised, and satisfied
- **Highlights on some recent developments**
 - detector description, physics, accessory capabilities, GRID etc.
- **Highlights on the on-going physics validation**
 - in the Geant4 Collaboration and in the experiments
- **Highlights on the user support activities**
 - examples, training courses, consultancy, problem reports etc.
- **Conclusions and outlook**

User requirements

- **Initially collected in RD44 (which responded to LCB)**
 - specified and analysed according to the **PSS-05** software engineering standard
 - Geant4 **User Requirements Document** (*on the web*)
- **Regularly updated and revisited**
 - various requirements engineering techniques adopted for capturing requirements
 - direct elicitation, study of past and future experiments, analysis of other codes etc...
 - most common elicitation techniques directly involving users:
 - solicit requests from experiments' simulation coordinators to Geant4 TSB
 - spontaneous requests from users to Geant4 Working Group Coordinators
- **Requirements management**
 - following well defined, agreed, documented procedures (*according to the guidelines of sound software engineering*)
 - well defined, agreed communication and decision channels
 - requirements involving more than one category are presented to Geant4 TSB
 - requirements affecting one category managed within the corresponding Working Group

User requirements

So far, all the requirements presented to the Geant4 TSB by LHC experiments have been satisfied (or are in progress of development)

- Software development cycle compatible with the available resources and the complexity of requirement
- *In some cases software, quickly developed by Geant4 as a consequence of requirements defined as “urgent, absolutely essential”, has not been used yet indeed in the requiring experiment years later...*
- A recent example of development cycle triggered by LHC requirement
 - requirement of “**cuts per region**”, presented by CMS
 - special **Geant4 release 5.1**, April 2003, scheduled in agreement with CMS according to their 2003 milestones (OSCAR and Physics TDR)

Cuts in Geant4 (previous to 5.0)

- Geant4 has had a unique production threshold ('cut') expressed in length (range of secondary)
 - for all volumes
 - possibly different for each particle
- This promotes
 - clear criteria for locality of energy deposition
 - better use of CPU – less 'wasted' in dense materials

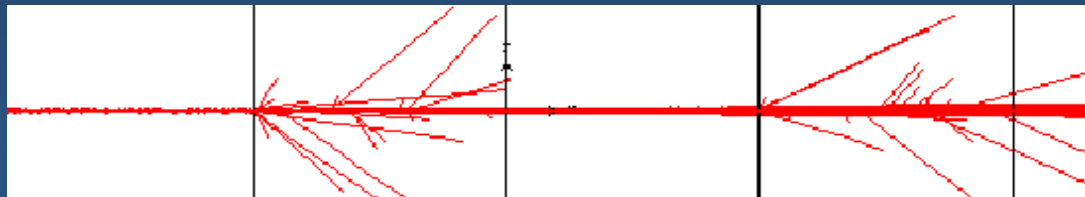

- Yet appropriate length scales can vary greatly between different areas of a large detector
 - eg. a vertex detector ($\sim\mu\text{m}$) and a muon detector ($\sim\text{cm}$)
 - having a unique (low) cut can create a performance penalty

Region and its properties

- Introduce the concept of « **region** »
 - set of geometry volumes
 - typically of a sub-system
- A cut in range is associated to a region
 - a different range cut for each particle is allowed in a region
- Typical uses
 - barrel + end-caps of the calorimeter can be a region
 - inner tracking detectors
 - etc.
- Major OOAD, implementation and test cycle
- Released Geant4 5.1, end April 2003

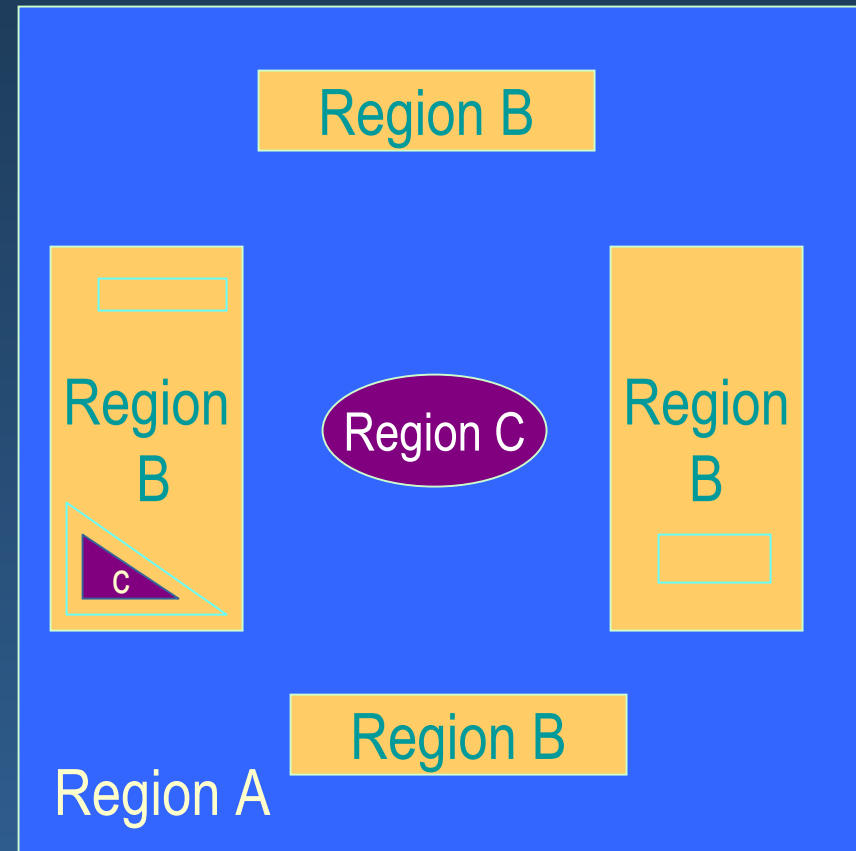

Note: *nothing is miraculous, there is a small performance penalty (~5%) for introducing a new feature*
– *further optimisation in progress*

However...

Globalisation

sharing requirements and functionality
across diverse fields

Reference: plenary talk at CHEP 2001, Beijing, Proceedings

Globalisation: sharing requirements and functionality across diverse fields

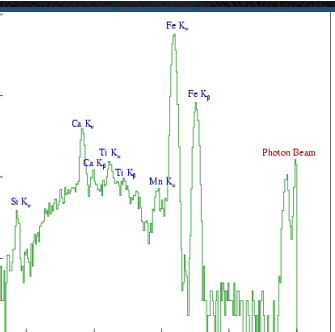
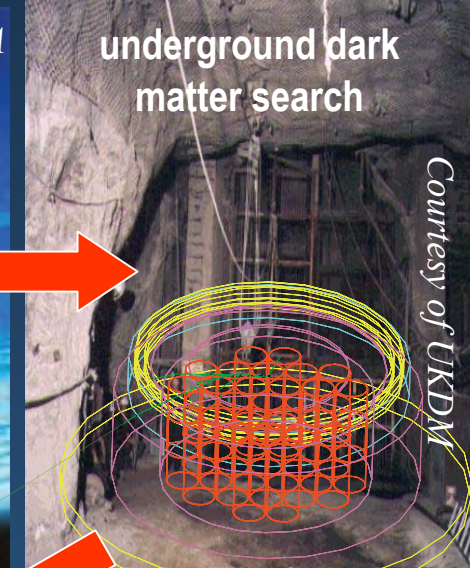
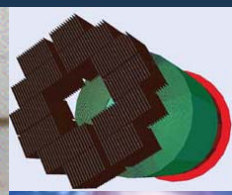
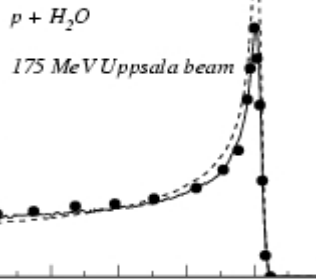
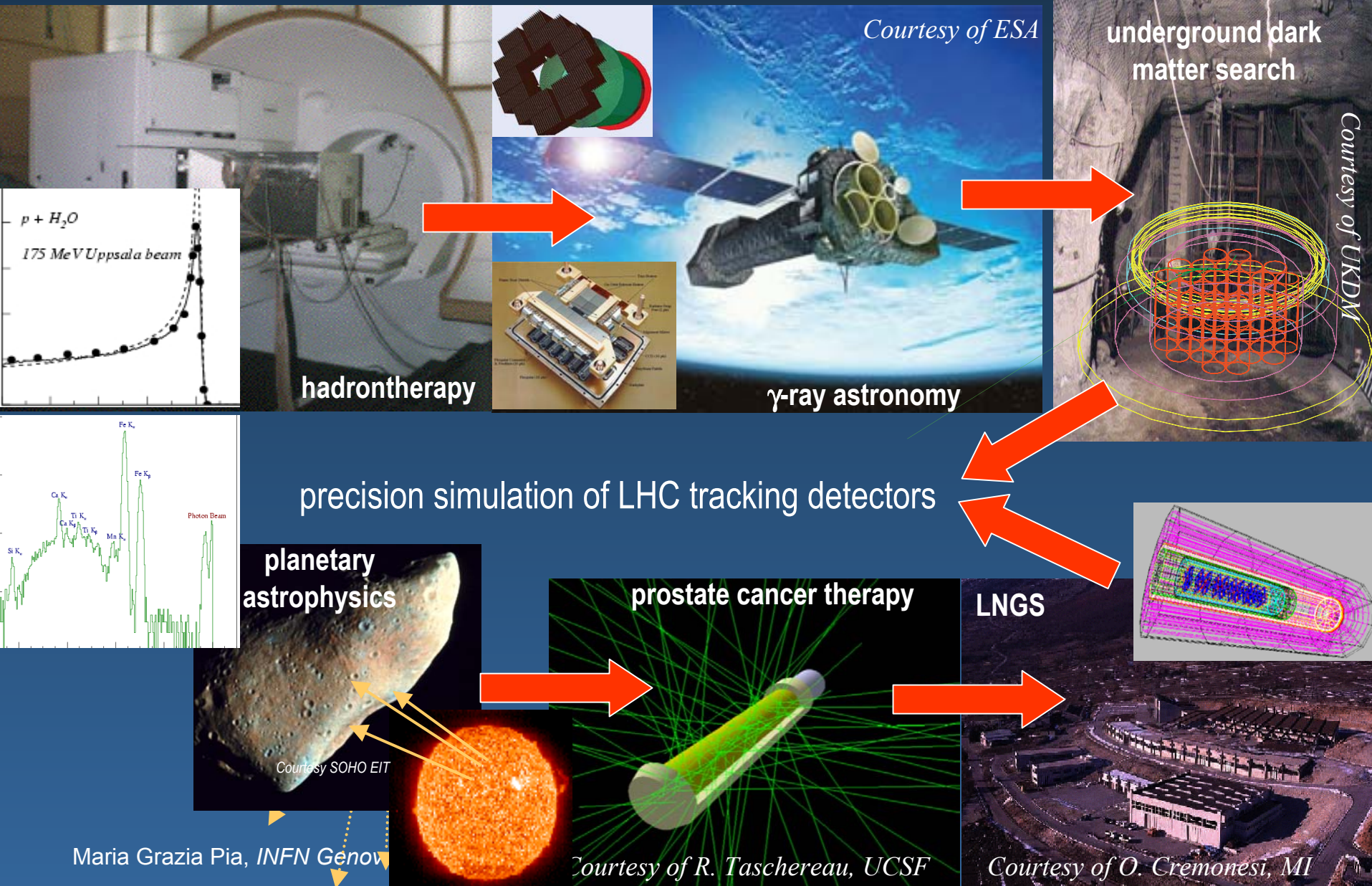

precision simulation of LHC tracking detectors

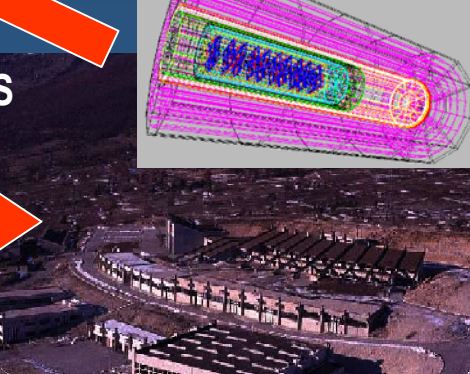

Maria Grazia Pia, INFN Genova

Courtesy of R. Taschereau, UCSF

Courtesy of O. Cremonesi, MI

Globalisation:

sharing requirements and functionality across diverse fields

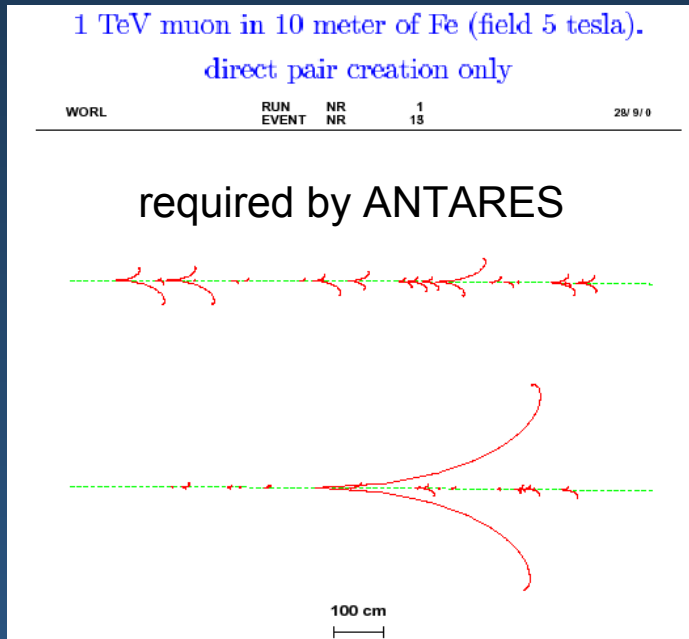

CMS
validation
(CHEP03)



via LEP $Z \rightarrow \mu\mu$

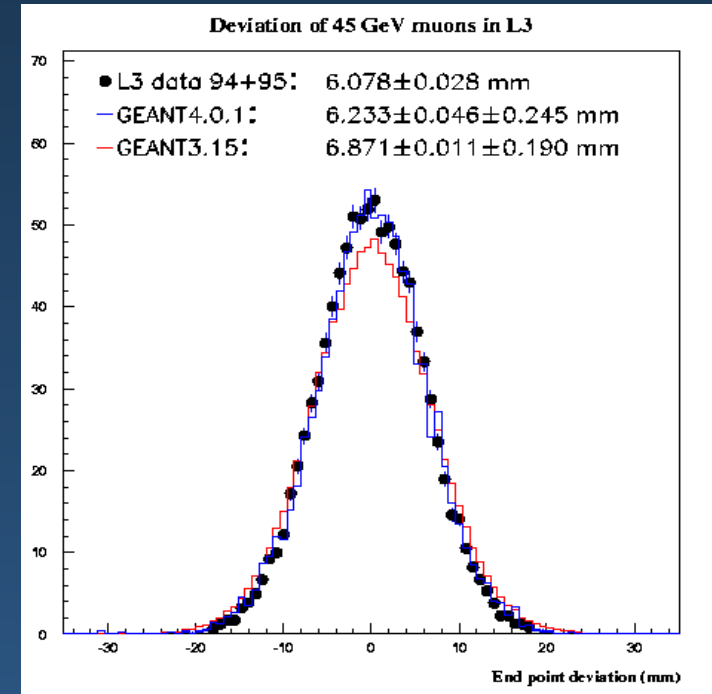

...and more:

CAD interface required by LHC,
heavily used by NASA

multiple scintillation devices required by LHC,
used by “underground” experiments

(some) Recent developments

- Kernel (*cuts per region*)
- Geometry
- Variance reduction
- Visualisation
- Electromagnetic physics
- Hadronic physics
- Integration in a distributed computing environment (GRID)

Highlights only, because of the limited time available!

More results available upon requests, if you are interested

(some) Recent developments: geometry

- **Detector description**
 - New ways to create geometries
 - Tools to detect incorrect geometry definitions
 - A different field for any volume (or volume tree), overriding a global field
- **Reflection of volume hierarchies**
 - eg. to create endcap geometry
- **Improved voxelisation for efficient navigation**
 - 3-D for parameterized volumes (now equal performance to ‘placed’ volume)
 - Option to avoid voxelizing some volumes
- **‘Illegal’ geometries detected and rejected**
 - e.g. incompatible daughters (placed & parameterized)
- **XML binding: GDML 1.0 released**
 - Specification & Implementation

(some) Recent developments: variance reduction

- Geant4 had leading particle biasing option for “low energy” neutrons
 - Now redesigned and improved
 - It was possible to use other methods, but only in user code
- Now new general purpose built-in methods have been released
 - Further refinements and methods are under development
- Importance biasing
 - Splitting/Russian roulette (*first released in G4 4.1, June 2002*)
 - Importance values can be associated to a volume
 - In the ‘mass’ geometry or in a dedicated ‘parallel’ geometry
 - Enabling simulation of shielding applications with improved time efficiency by large factors
 - Varied options in driving MC ‘history’ and scoring tallies
 - No changes to the kernel were required, due to the flexibility of the toolkit
- Leading particle biasing
 - à la MARS95, for $E_n < 5$ GeV

(some) Recent developments: visualisation

New

- “DTREE”: hierarchy display
- HEPREP driver for WIRED

Other current drivers

- also from others
- eg. IGUANA (for CMS simulation), by CMS Iguana Team

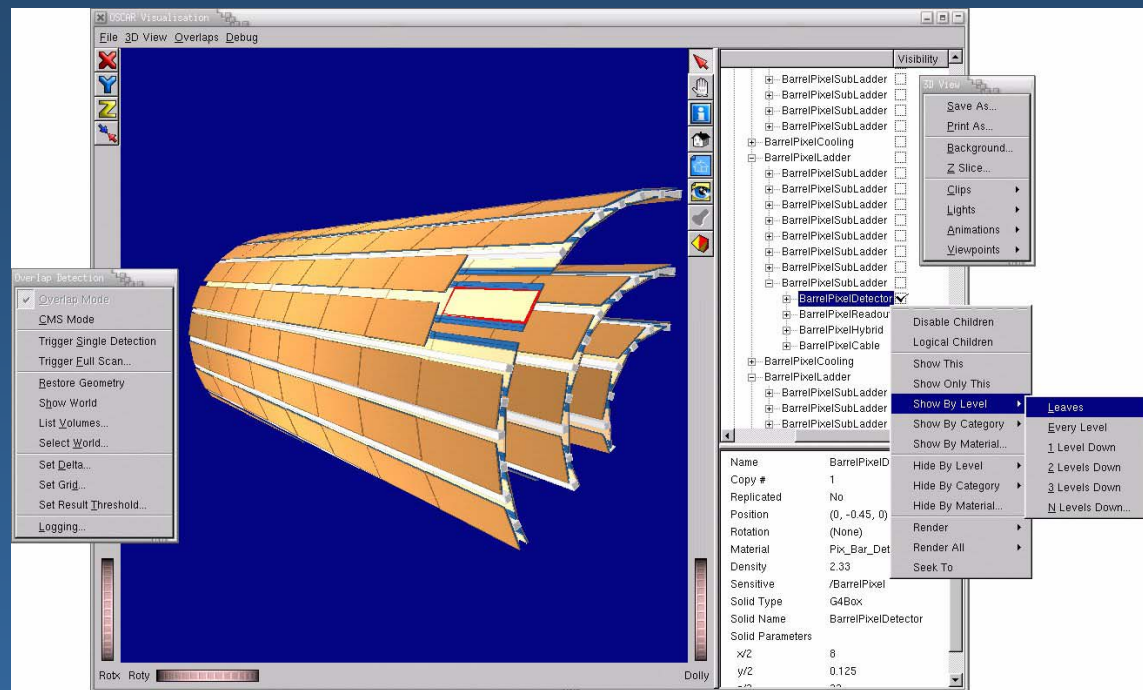

(some) Recent electromagnetic developments

- Multiple scattering
 - Angular distributions (see next slides)
- Ultra relativistic energies
 - $\gamma \mu \mu$ process
- Ionisation for Generic Ions
- New model of Transition Radiation
- New models down to lower energies (100 eV) for microdosimetry
- Improvement and extension of scintillation
- etc.

Improved multiple scattering model

Refined modeling of angular distributions

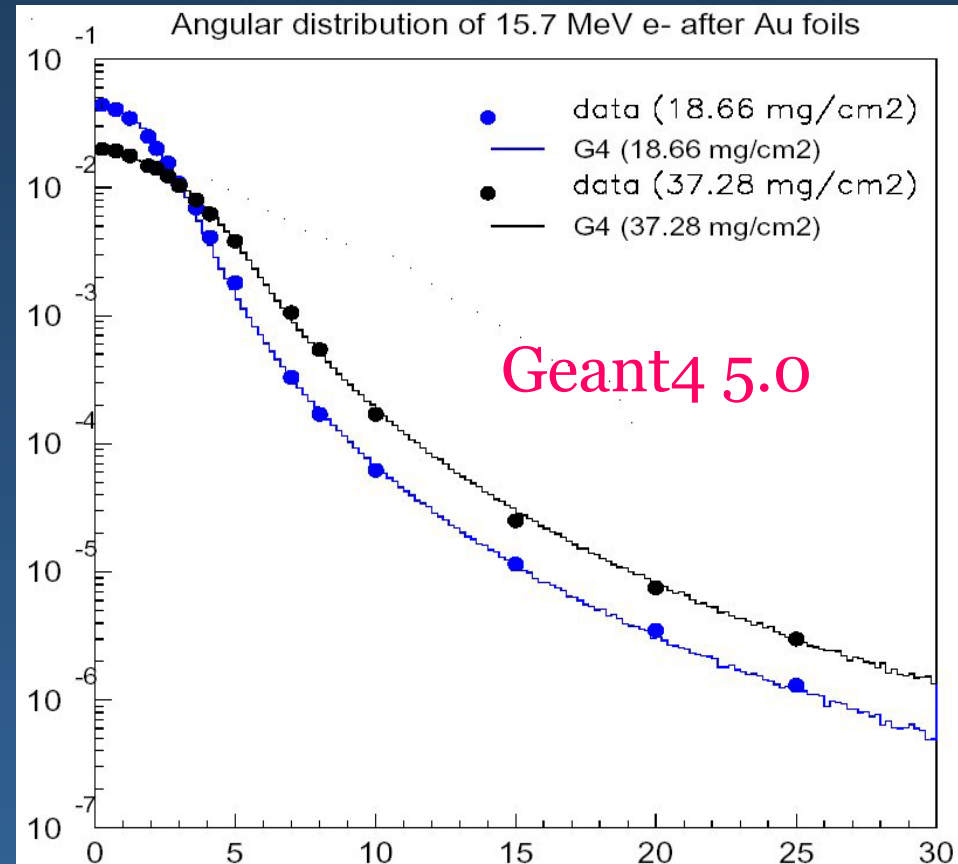
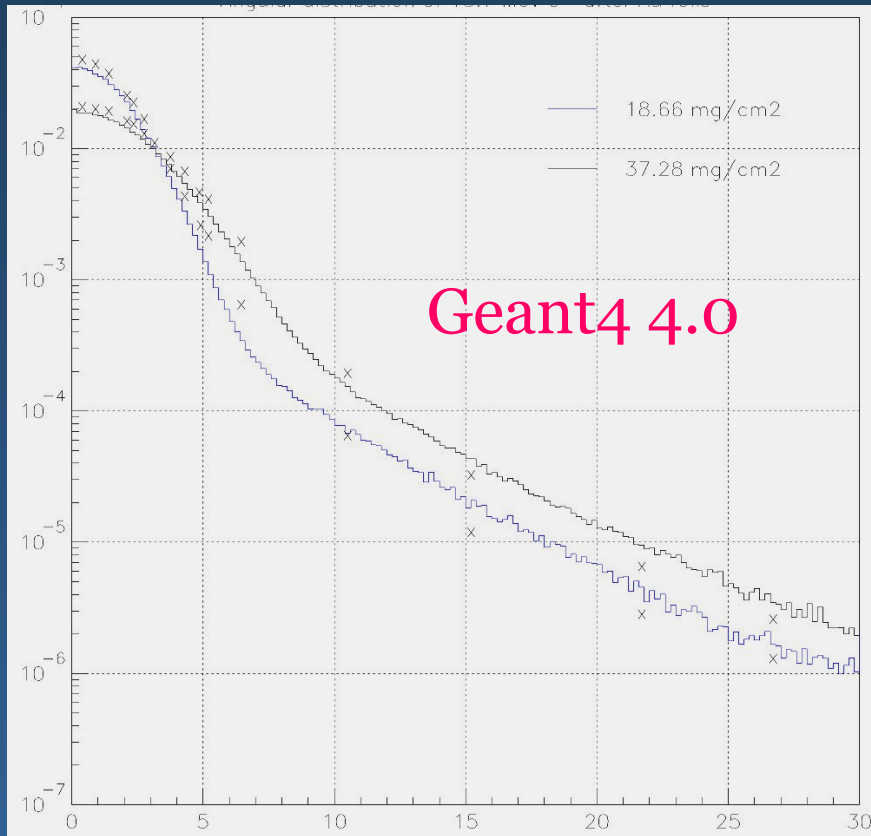

Apologies for the poor quality of some of the next slides

Text captured with a graphical editor from
J.-P. Wellisch's CHEP presentation
(147 MB, file type .prn),
original not available to Geant4 Collaborators

Hadronic physics: new features in Geant4 5.0 release

- First release of Binary cascade (BC)
- First release of classical (Bertini) cascade (CC)
- First release of a generic scattering term for cascade models.
- First release of internal conversion
- Chiral invariant phase-space decay (CHIPS) for electro-nuclear with $Q^2 > 0$.
- Quark gluon string model for real and virtual gamma reactions

Text captured with a graphical editor from J.-P. Wellisch's CHEP presentation (147 MB, file type .prn), original not available to Geant4 Collaborators

Binary cascade: the model

The name binary cascade comes from the fact that only binary collisions (and decay) are considered, like



- A 3-dimensional nuclear model is built up, as for quark gluon string model
- The impact parameter is sampled
- The time to closest approach to the nucleons in the nucleus is calculated
- Reactions are selected according to hadron nucleon cross-section
- The system is transported in the nuclear potential to the time of the earliest reaction or decay
- Products are created and subject to pauli's exclusion principle accepted.
- The procedure is repeated for all products, allowing for re-scattering.

isch,
P/SET

Text captured with a graphical editor from J.-P. Wellisch's CHEP presentation (147 MB, file type .prn), original not available to Geant4 Collaborators

Bertini cascade: the model

- Physical justification: if the **deBroglie wavelength** of the incident particle is comparable to the average intra-nucleon distance, **interactions can be treated in terms of particle-particle (N-N) collisions**
- Bertini INC solves the **Boltzman equation** on the average
- Physical foundation comes approximate if $E < 200 \text{ MeV}$ or $E > 10 \text{ GeV}$
- Pre-equilibrium model developed to support low energy treatment

- 1947: **INC** first **proposed** by R. Serber
- 1948: M. Goldberger made first **calculations by hand**
- 1958: First **computer simulations** by N. Metropolis
- 1966: **exiton model** by J. J. Griffin
- 1968: H. W. Bertini published **standard methods** to be used in many INC implementations
- 1970's: **HETC**
- 1990's: **INUCL** code by N. Stepanov

re-engineered into Geant4

16K lines in 32 classes

(4K lines for testing and documentation)

1. The spatial point, where the incident particle enters, is selected uniformly over the projected area of the nucleus.
2. **N-N cross sections** and **region-depenent nucleon densities** are used to select a path lenght for the projectile particle.
3. The momentum of the struck nucleon, the **type of reaction** and four momentum of the reaction products are determined.
4. **Exiton model** is updated as the cascade proceeds.
5. If **Pauli exclusion principle** allows and $E_{particle} > E_{cutoff} = 2 \text{ MeV}$, step (2) is performed to transport the products.

Courtesy
A. Heikkinen, CHEP03

Maria Grazia Pia, INFN Genova

Geant4 in a distributed computing environment

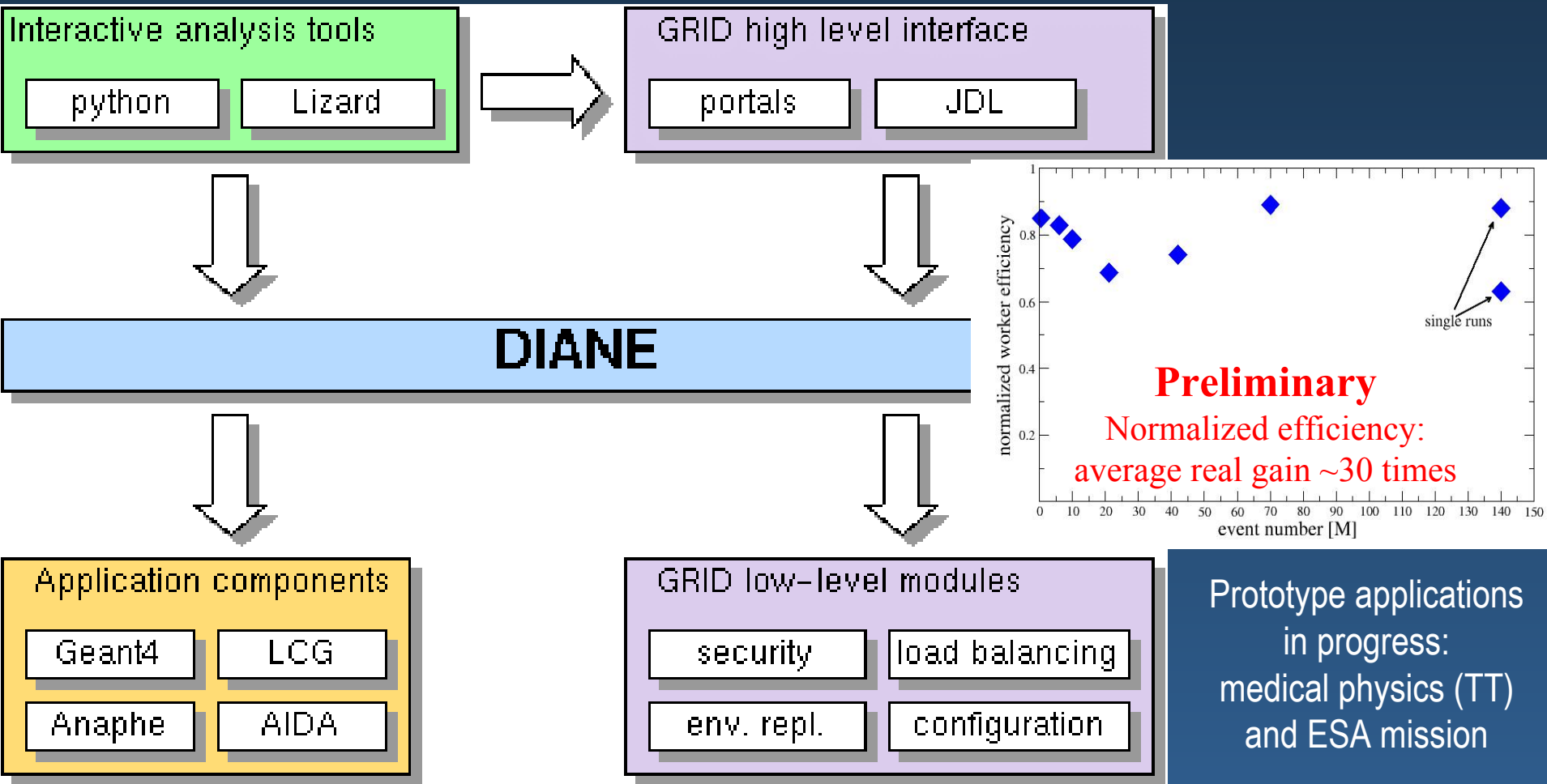

Preliminary results presented at Siena Conference in October 2002

Work at INFN Genova, in collaboration with CERN (J. Moscicki)

CPU performance: work in progress

- Our first simple benchmarks:
 - geometry faster
 - EM shower setups: competitive
- Performance in experimental setups with Geant4 releases 2 and 3 was comparable to Geant3
- New performance issues arose with Geant4 4.0
 - and were addressed (in the patches & release 4.1)
- Difficult cases remain, including
 - some setups of EM showers and field propagation, factor ~ 2
- Collecting a set of benchmarks
 - to follow computing performance regularly
- Goal is that Geant4 is at least as fast as Geant3 in almost all cases
 - *with all the additional power & capabilities it provides w.r.t. Geant3*
- **Work in progress**
 - *please, no need to take dramatic actions...*
- **NOTE: optimisation may be needed in user code too**
 - *we have examples of user code significantly improved by us (even by a factor 20...)*

(some) Recent validation results

- BaBar
- Atlas
- CMS
- LHCb

Highlights only, because of the limited time available!

More results available upon requests, if you are interested

- + Geant4 internal
- All results publicly available
- ...as well as Geant4 source code used to produce them

π^0 reconstruction in BaBar

π^0 mass – test of tracking, energy scale, containment in calorimeter

π^0 width – depends on shower simulation, detector response to photons

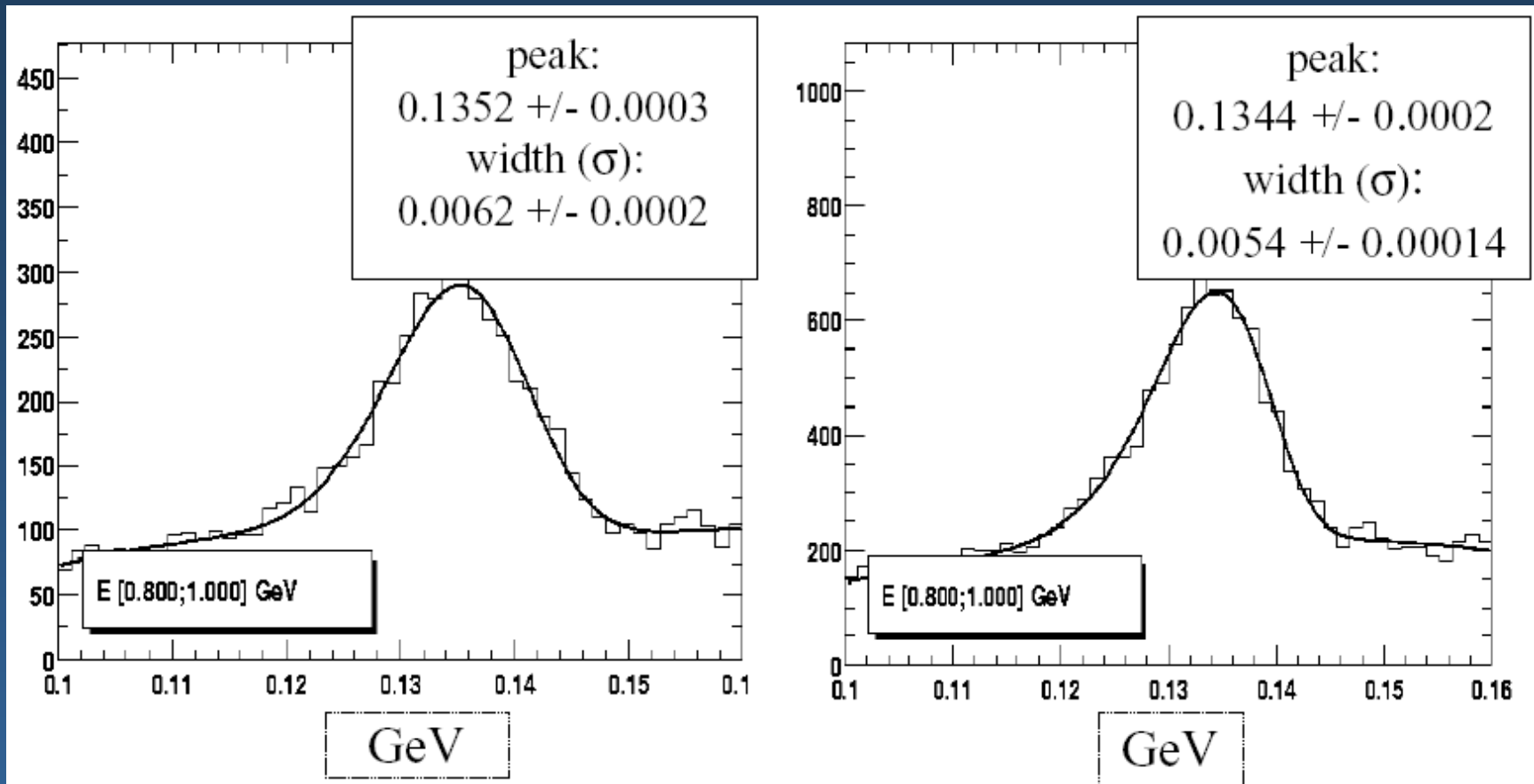

BaBar: calorimetry

shower shapes

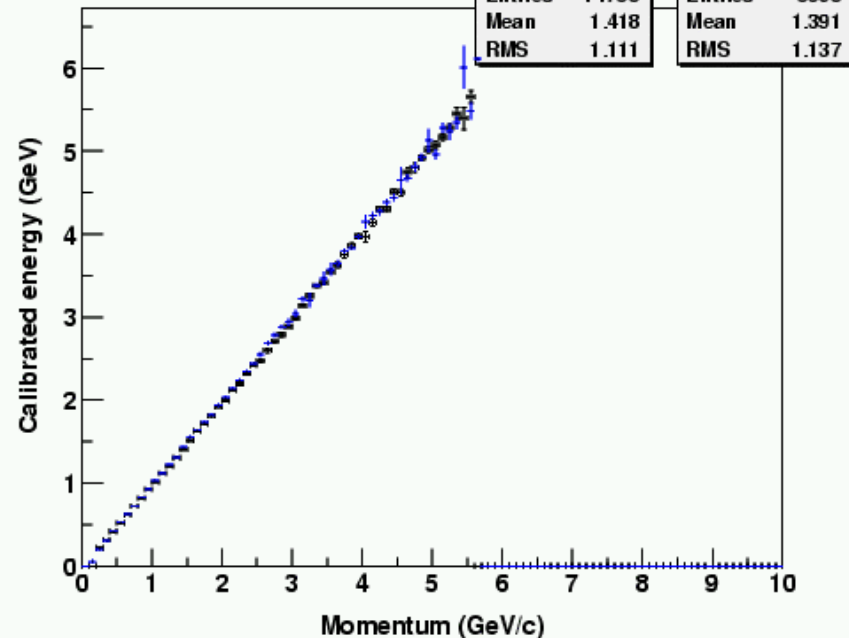
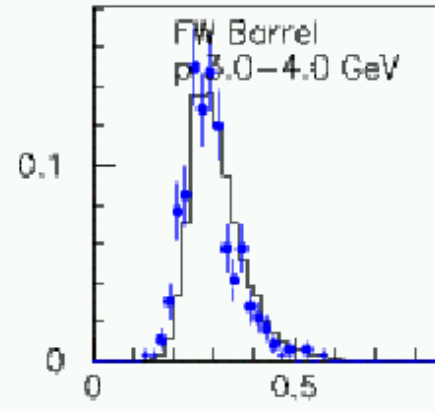
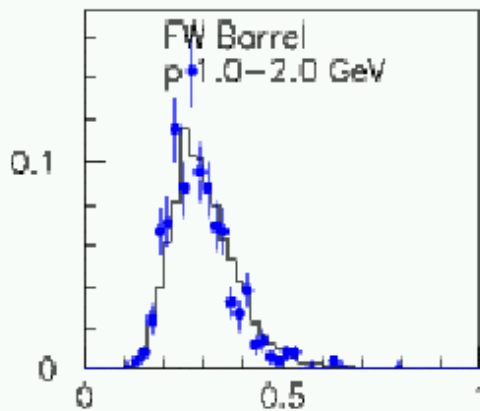
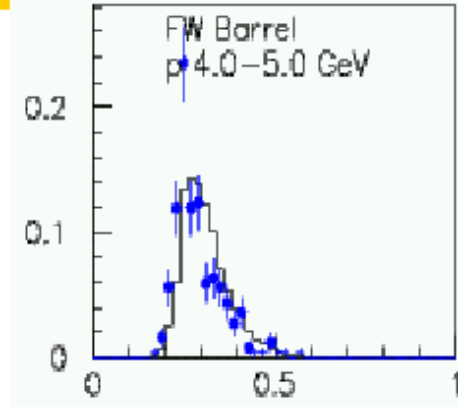
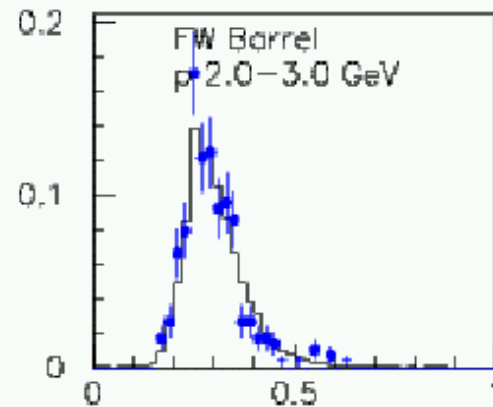
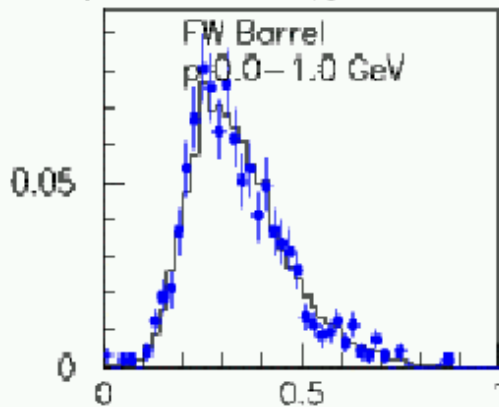

BaBar: tracking

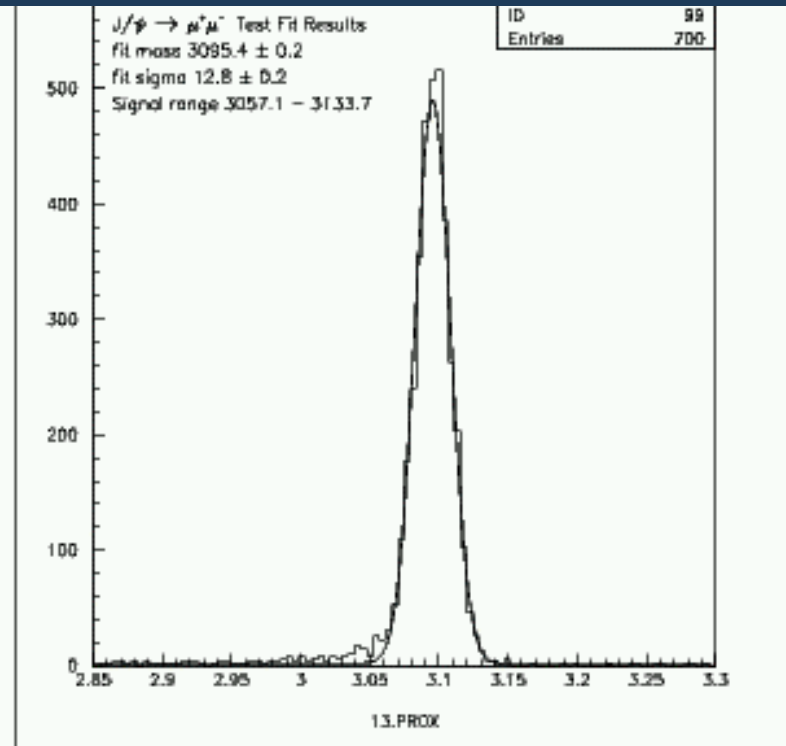
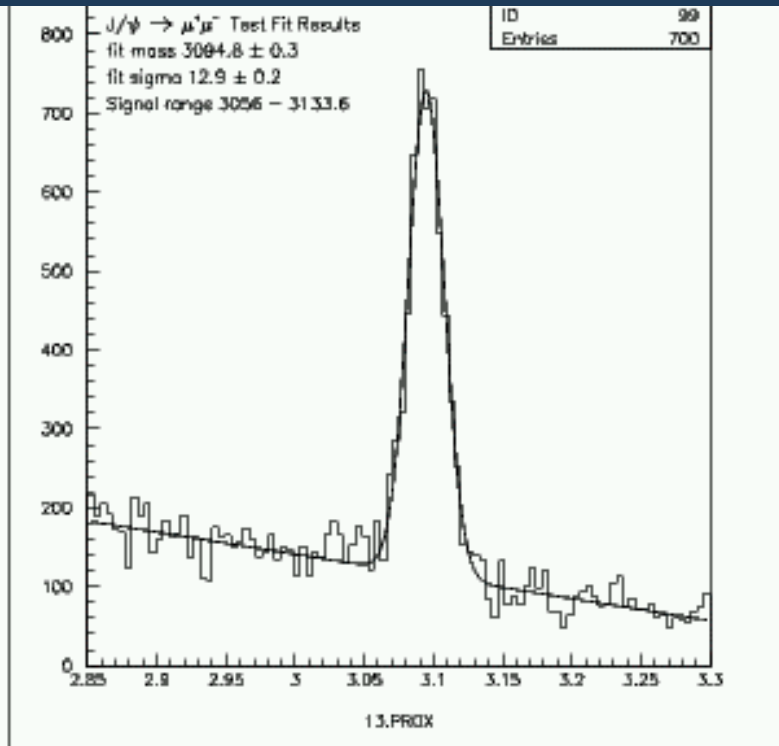

data: $m\text{-PDG} = -2.1 \pm 0.3$ MeV

MC: $m\text{-PDG} = -1.5 \pm 0.3$ MeV

BaBar conclusions, CHEP03 (D. Wright)

- ✱ BaBar is the first large experiment to develop and use a Geant4-based simulation
- ✱ EM validation well in hand
 - Some differences between MC and data but so far probably due to detector response simulation
- ✱ Hadronic validation beginning in earnest
 - Testing low energy parameterized, binary cascade, Bertini cascade models
 - BaBar thin target tests just beginning
- ✱ Simulation is robust and reasonably fast

Currently running MC production at ~20 sites (1440 M events so far)

Hadronic physics tests with test beams

Hadronic test-beam comparisons come from collaboration of experiments' detector groups with 'core' geant4 personnel.

- ATLAS Tile test-beam
- CMS Tile test-beam
- ATLAS HEC test-beam
- ATLAS FCAL test-beam
- BTEV crystal test-beam
- CMS combined test-beam
- CsI test-beam benchmark
- GLAST (starting) test-beam
- H1 forward barrel (starting)
- ATLAS combined endcap (starting)

Johannes-Peter Wellisch
(CERN)

Text captured with a graphical editor from J.-P. Wellisch's CHEP presentation (147 MB, file type .prn), original not available to Geant4 Collaborators

Hadronic physics: models, processes and 'PhysicsLists'

⌘ 5-level implementation
framework

⌘ Variety of **models** and
cross-sections

- ⊞ for each energy regime,
particle type, material
- ⊞ alternatives with different
strengths and CPU requirements

Components can be assembled in an
optimized way for each **use case**

Material (element)

particle

Energy

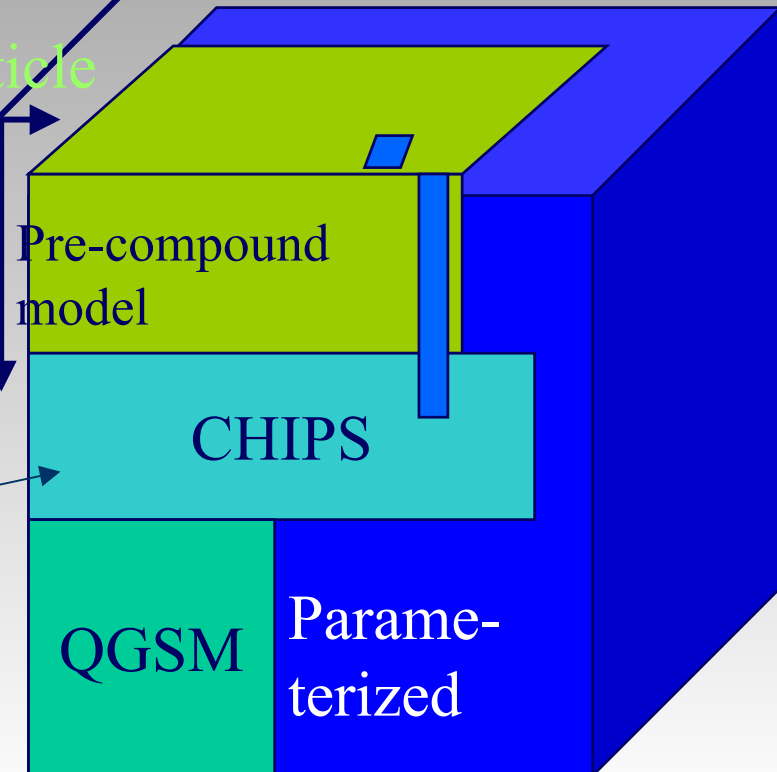

Pre-compound
model

CHIPS

QGSM

Parame-
terized

We have created what is the most complete
hadronic simulation engine in the world

● Illustrative example of assembling
models into an inelastic process for set
of particles

– Uses levels 1 & 2 of framework

Guidance to users

- Mastering Geant4 hadronic physics is complex
 - many models, options, great flexibility
- Guidance to users provided by the Geant4 Collaboration
- Created and distribute “educated guess” physics lists
 - That correspond to the **major use cases** of Geant4 involving hadronic physics
 - to use directly, and as a starting point for users to modify
 - facilitate the specialization of those parts of hadronic physics lists that vary between use cases
- Revised with experience of comparisons with data
- Find them on J.P.’s Wellisch private web page
<http://cmsdoc.cern.ch/~hpw/GHAD/HomePage>
I asked several times to bring them to Geant4 web and CVS repository...
- Electromagnetic physics
 - guidance mostly from examples (extended examples and advanced examples)

Hadronic Parameterised models in BaBar

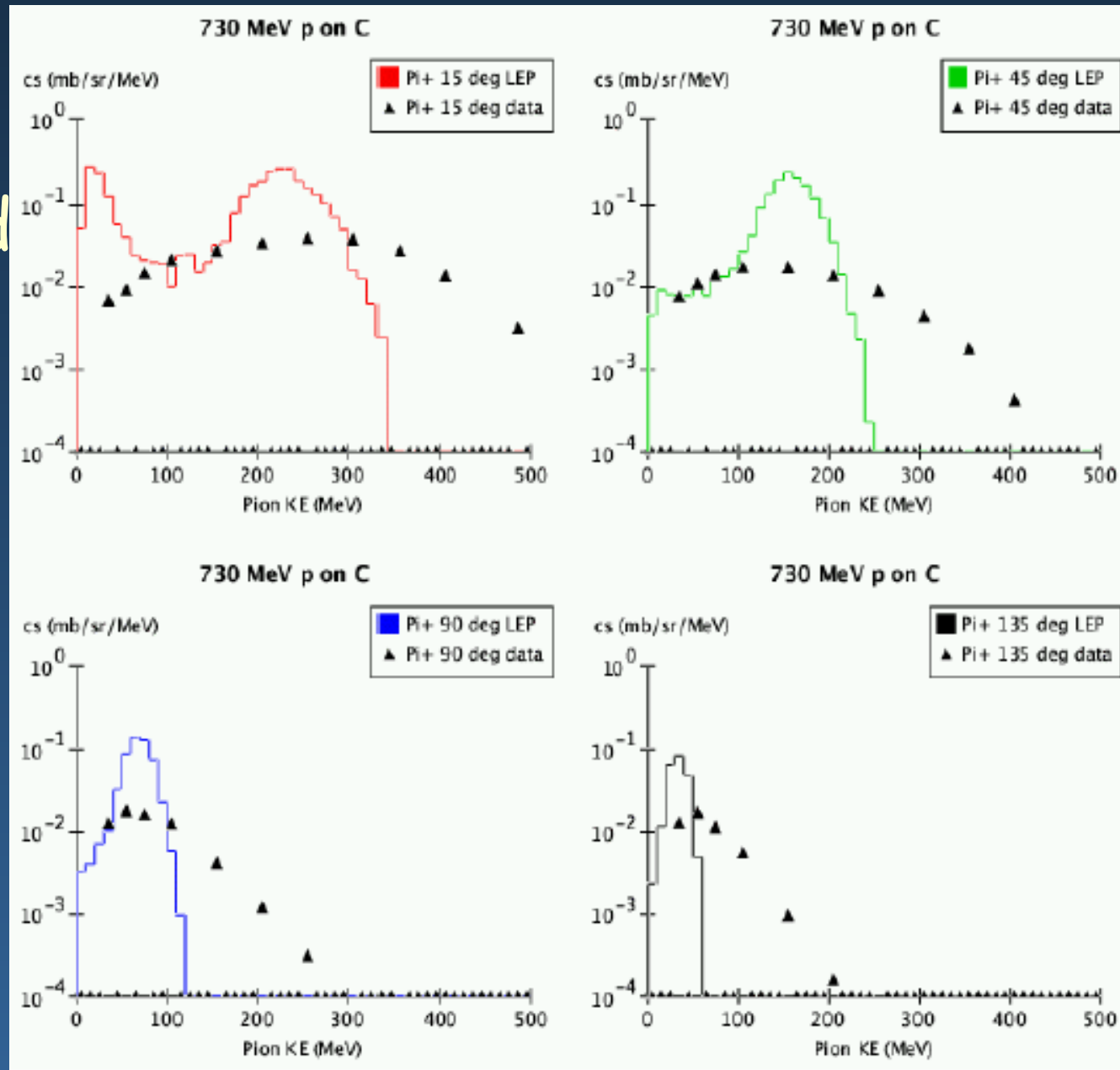

Hadronic Parameterised models in CMS

100 GeV pi+

0 Tesla

ECAL+HCAL

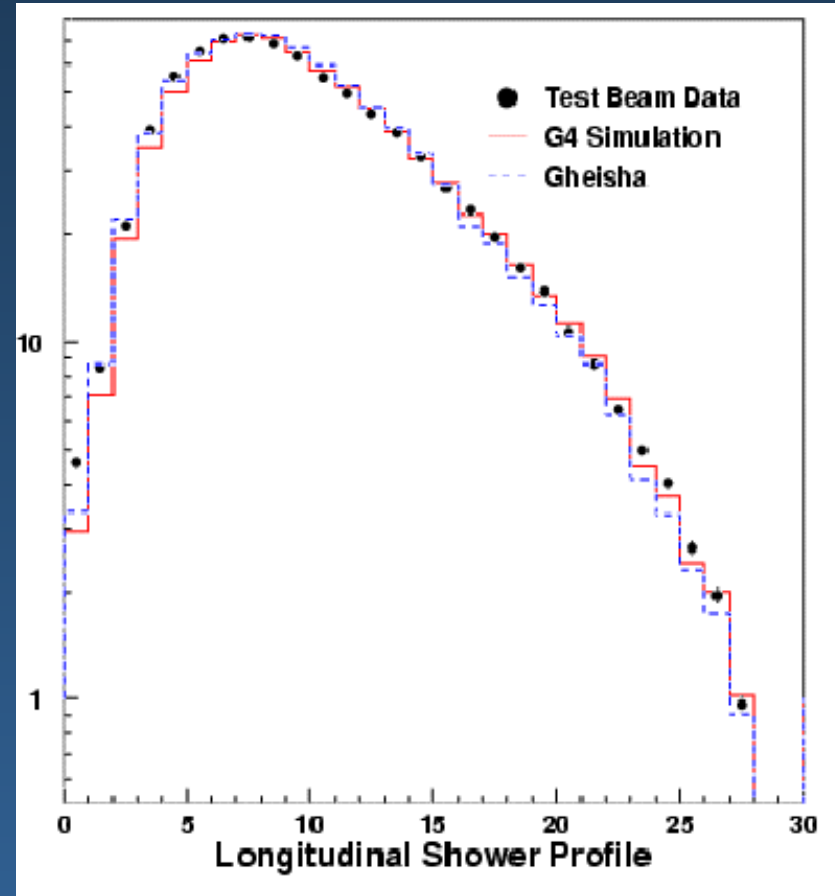
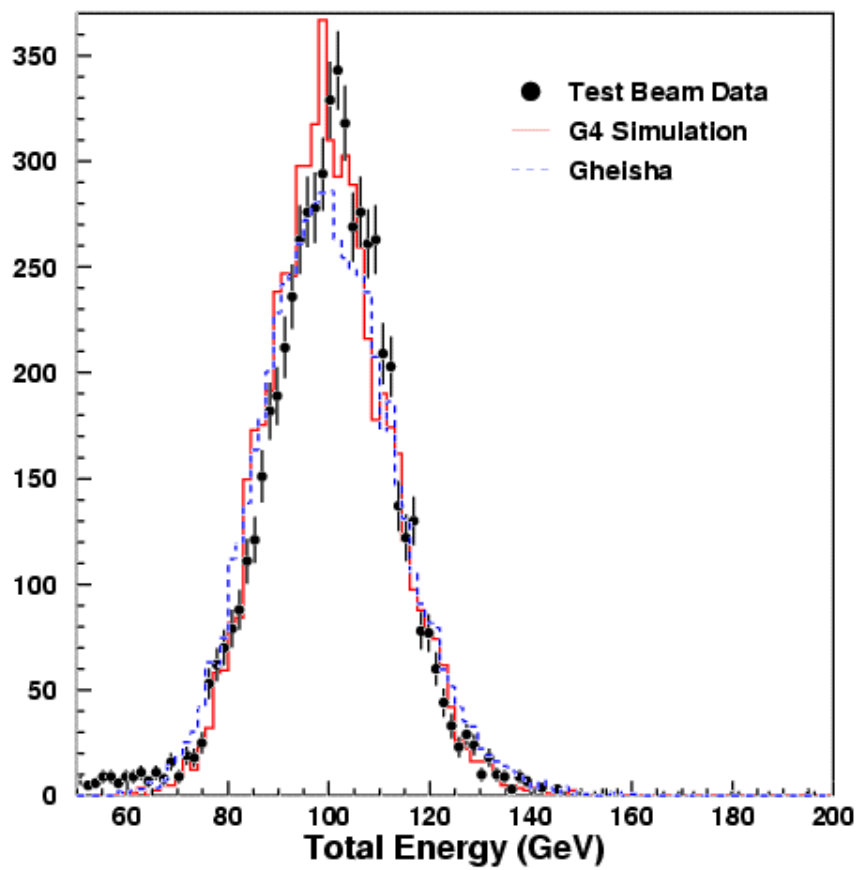

Bertini cascade in BaBar

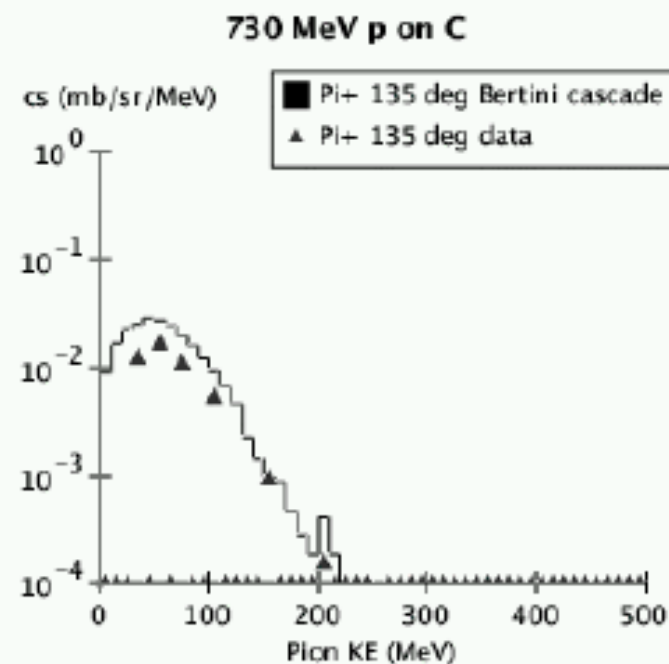
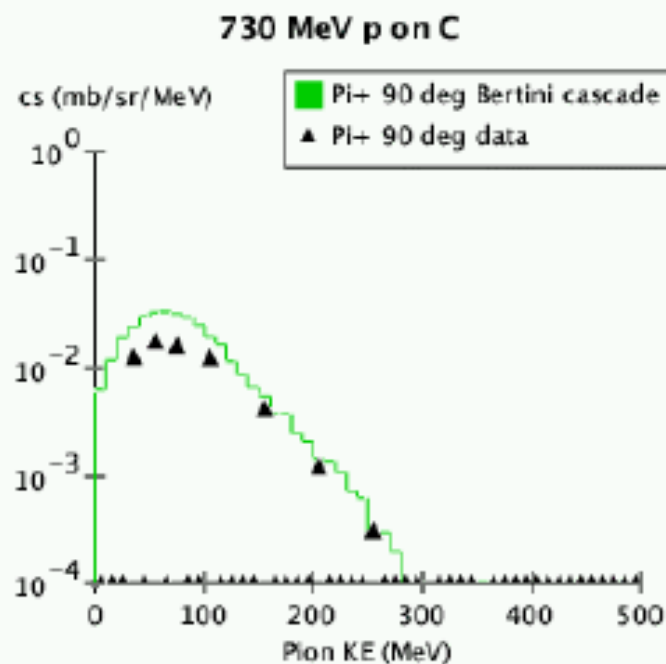
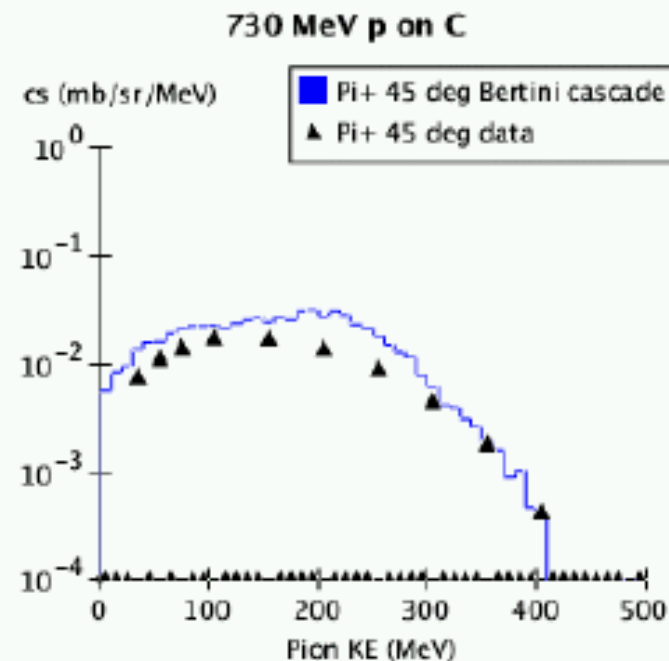
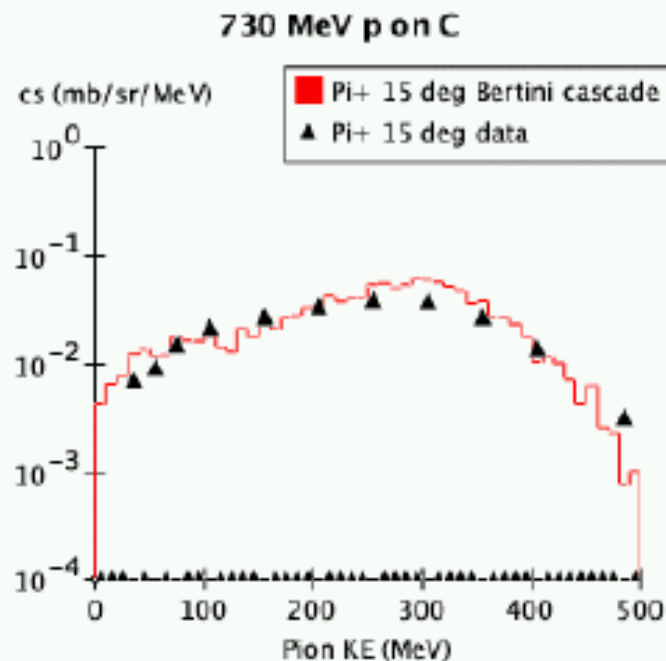

Advantages and responsibilities of using a toolkit

- There is no such thing as a “good model” or a “bad model”
 - a model may be more or less appropriate for a given energy range, material, particle type
- Guidance from “educated guess” PhysicsLists (*available from the web*)
 - optimisation of the choice of models picked from the Toolkit in a **specific** experimental context is a **user’s responsibility**
 - *one doesn’t expect to build the experiment’s simulation blindly, does one?*
 - *...as one doesn’t build the hardware blindly*
 - documentation and support from Geant4 Collaboration
- A big step forward w.r.t. Geant3
 - monolithic “black boxes” (either take all or nothing)
 - Fluka, Gcalor, Gheisha
 - let’s not forget that Geant4 is still the first and only simulation **toolkit** on the market

Parameterised models: test beam comparisons

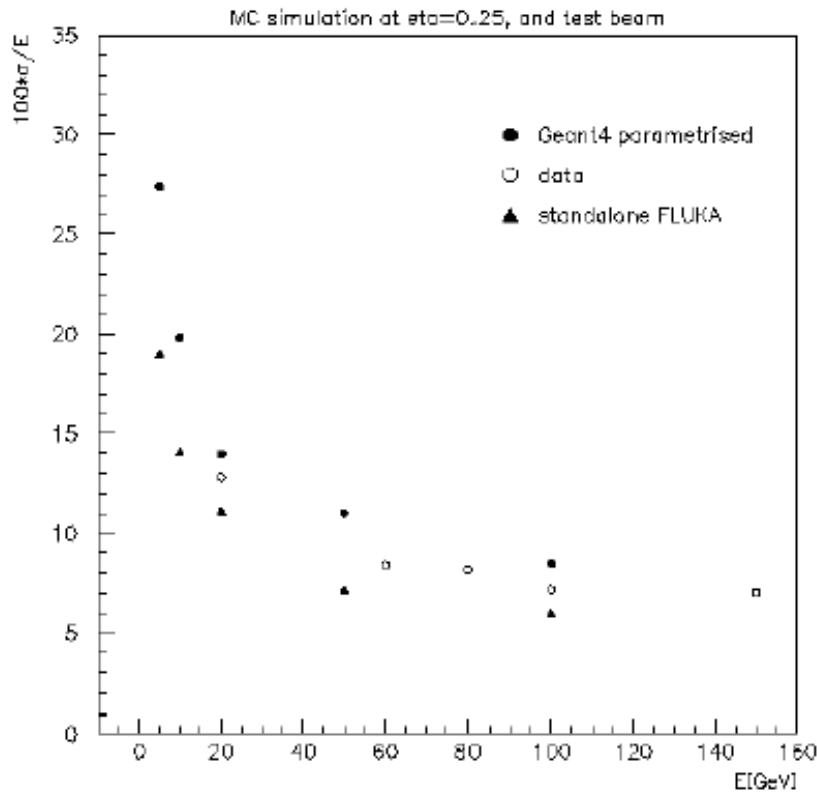

Wellisch,

ATLAS TILE prelim.

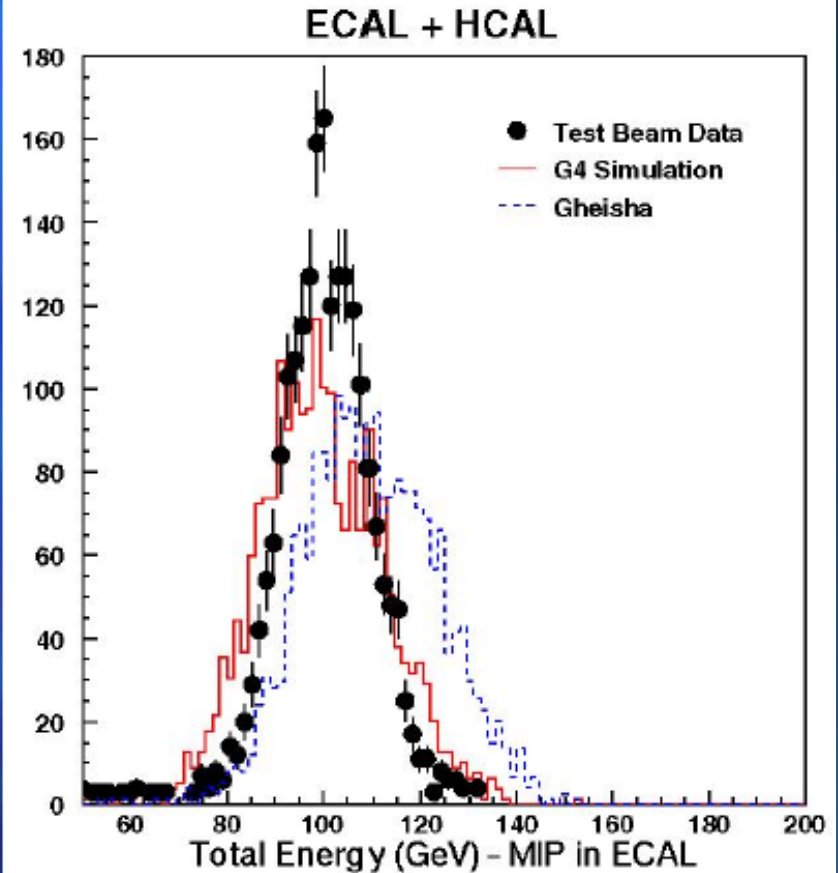

CMS combined prelim.

Text captured with a graphical editor from J.-P. Wellisch's CHEP presentation (147 MB, file type .prn), original not available to Geant4 Collaborators

Theoretical models: test beam comparisons (ATLAS note, Jan. 2003)

Warning:

still Geant4 4.1,

no cascade model activated

Courtesy of ATLAS

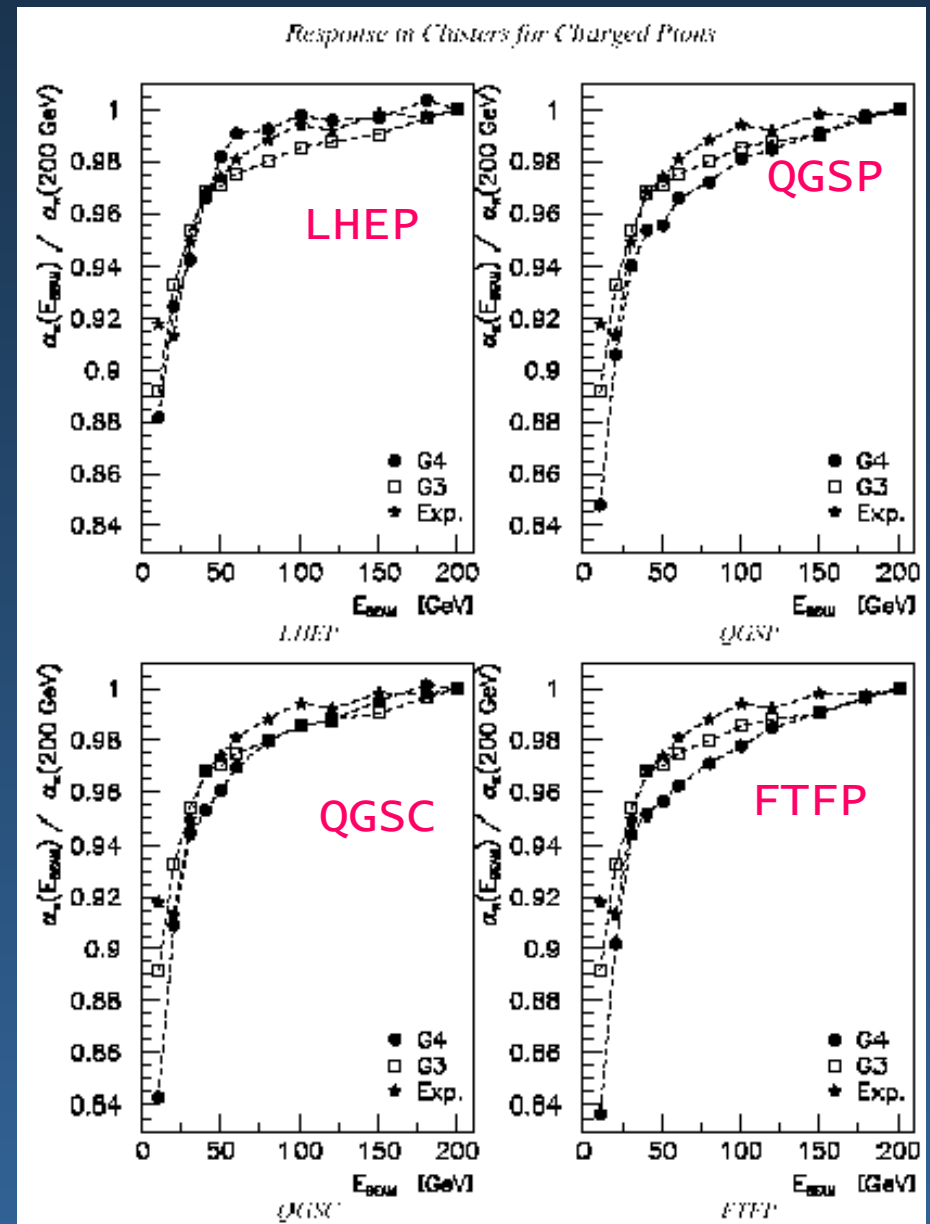

Warning: beware that some experiments may not be always up-to-date with Geant4 releases...

Version 4.1 (June 2002) still used in April 2003
(5.0 released in December 2002,
5.1 in April 2003)

- **Geant4:**

- **version 4.1 with patch-01 (July 31, 2002)**

- -- IEC testbeam setup (version 3)

- -- range cut ----- 700 μm

- -- simulation of energy scans with negative pions and electrons

- **Four physics lists for calorimetry from H.-P. Wellisch**

- (<http://www.cern.ch/~hgw/GHAD/HomePage/calorimetry/index.html>)

features available in Geant4 often used by the experiments with some delay... lack of manpower?

Comparisons: resolution

Experiment's

data

FLUKA
(latest)
simulation

Geant3
(CALOR)
simulation

+ various
PhysicsLists,
with different
Geant4 hadronic
models

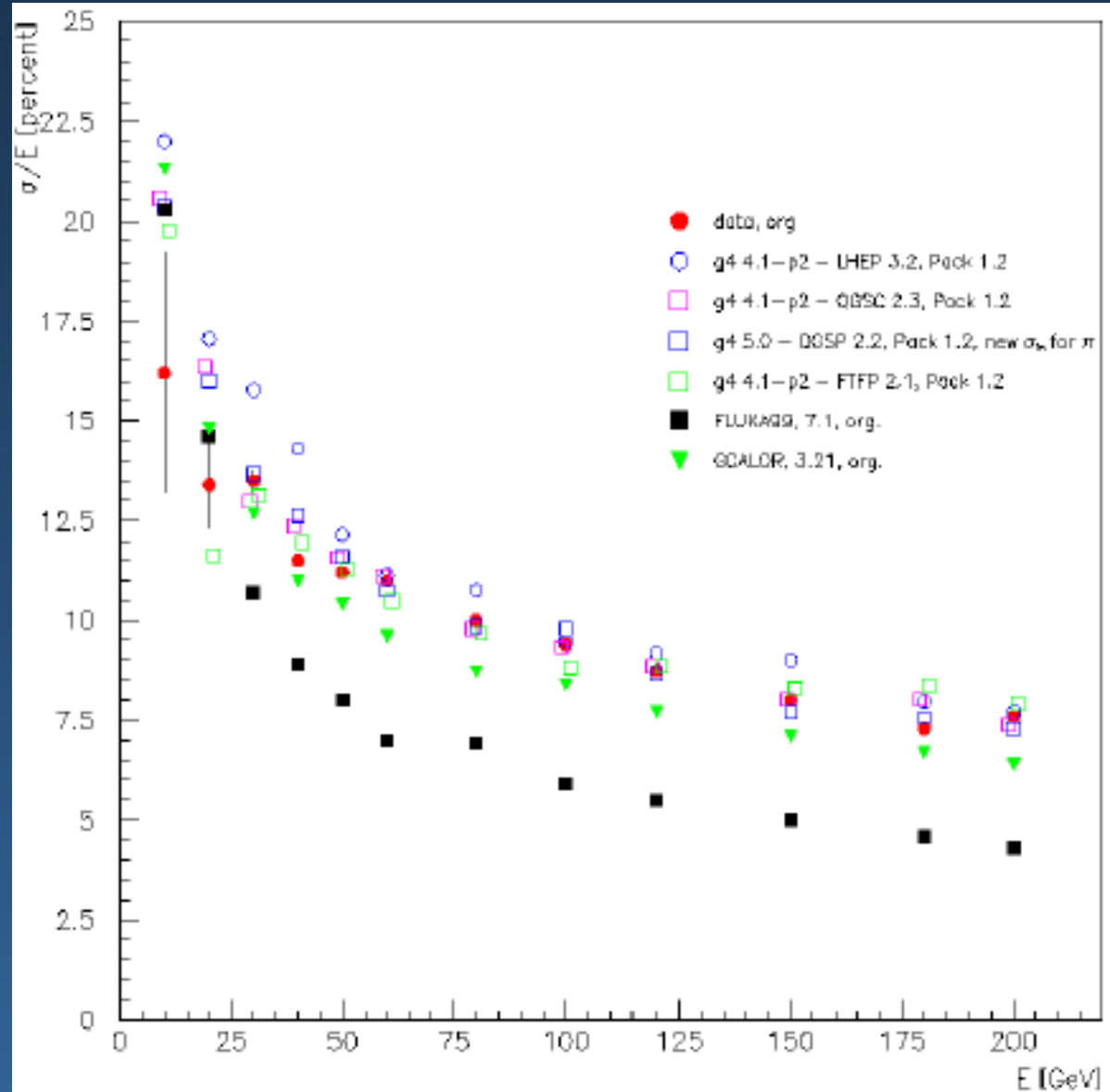

Comparisons: e/π

Experiment's

data

FLUKA
(latest)
simulation

Geant3
(CALOR)
simulation

+ various
PhysicsLists,
with different
Geant4 hadronic
models

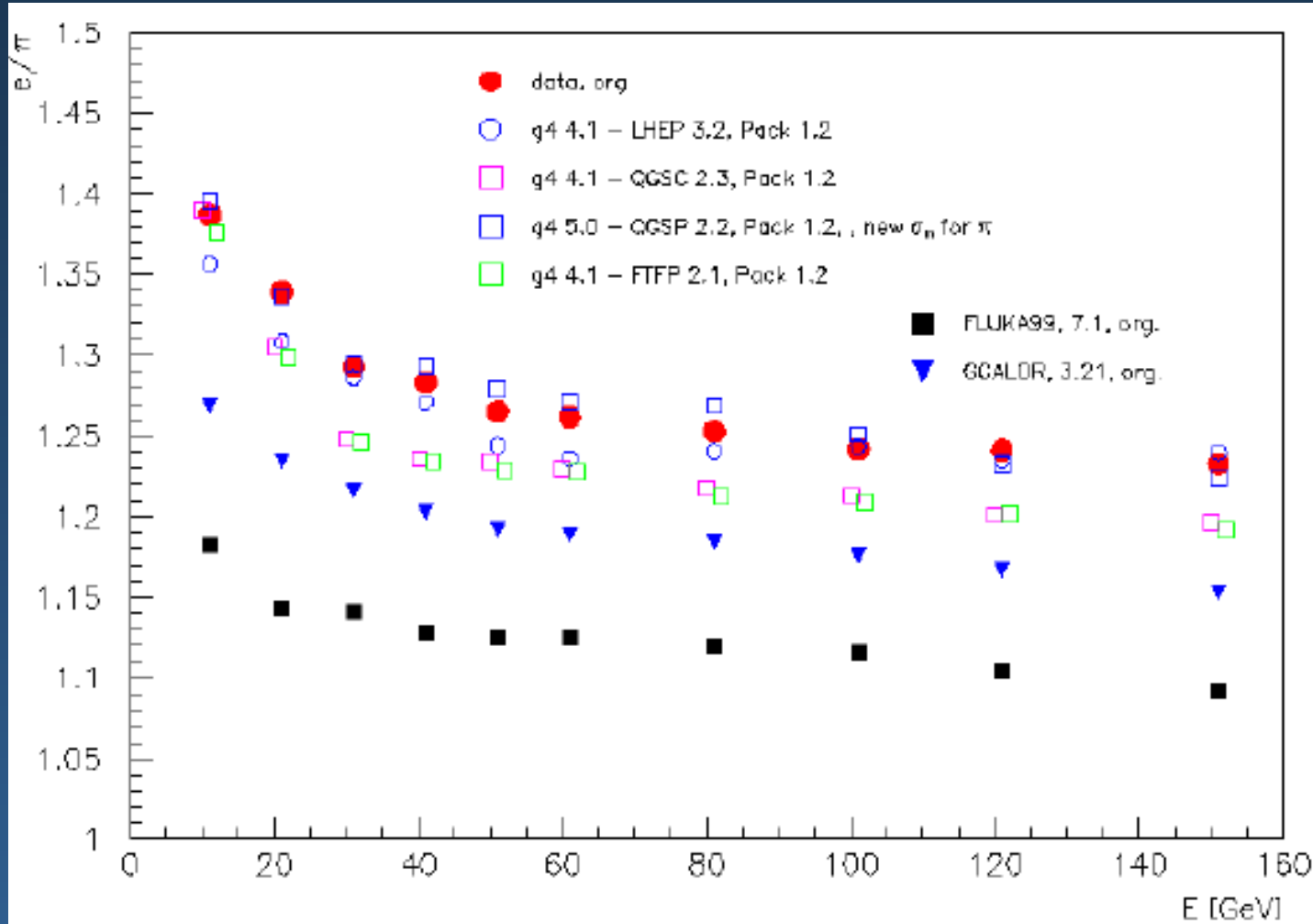

Further work in progress, shower shapes etc.

Simulation of the LHCb RICH test beam setup using GEANT4

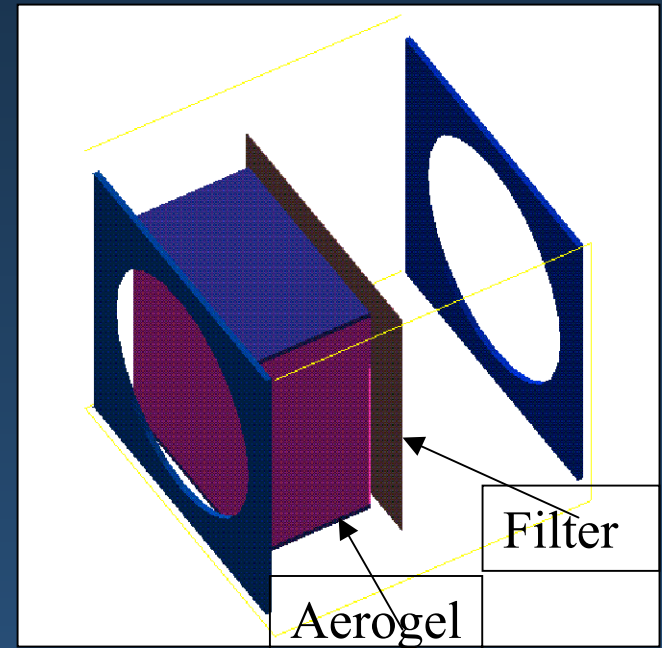
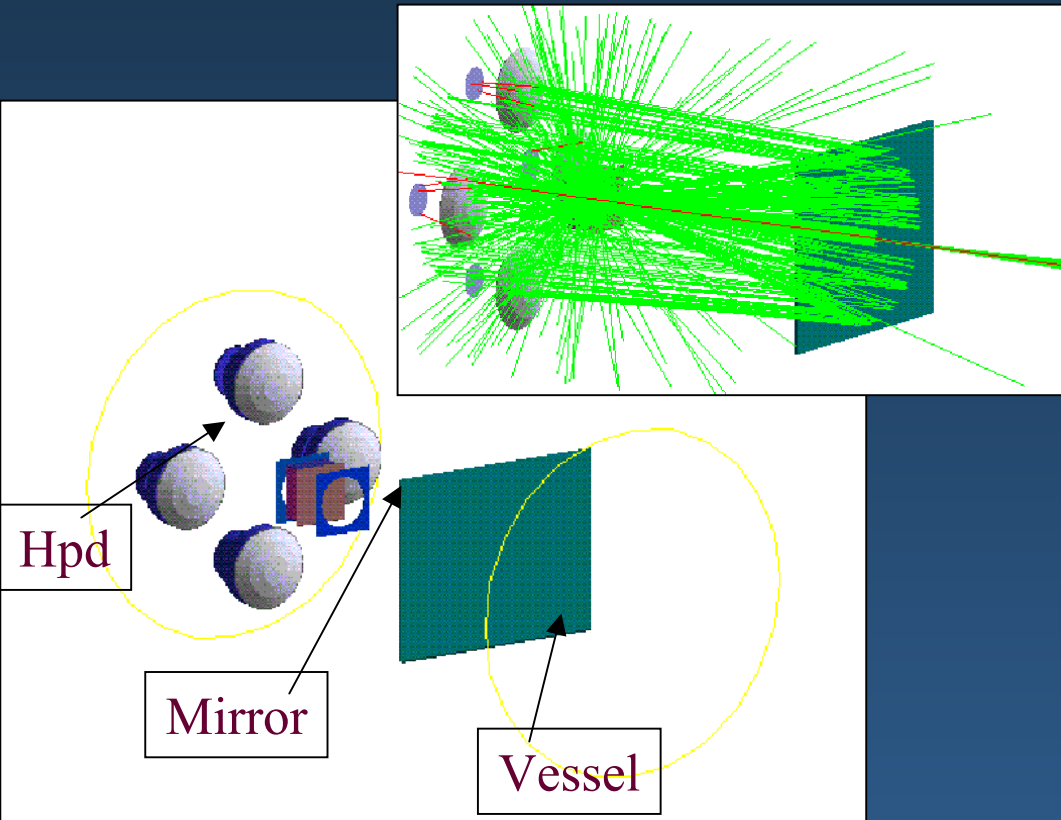

Courtesy of S. Easo, LHCb

Photoelectron yield

Novosibirsk	No Filter	Filter D263
4 cm	9.7 ± 1.0 11.5 ± 1.2	6.3 ± 0.7 7.4 ± 0.8
8 cm	12.2 ± 1.3 14.7 ± 1.6	9.4 ± 1.0 10.1 ± 1.1

Data

MC

Cherenkov angle reconstruction

Thickness	No filter		Filter D263	
4 cm	250.0	5.4	247.1	5.0
	248.7	4.0	246.8	3.1
8 cm	246.8	5.8	245.4	4.8
	245.0	3.9	243.7	3.0

Test & Analysis project →

major role played by Geant4-INFN

quantitative
physics validation
of Geant4

Test & Analysis

is a project to develop a statistical analysis system for usage in [Geant4] testing

Main application areas:

- ◆ physics validation
- ◆ regression testing
- ◆ system testing

Interest in other areas, not only Geant4 →

LCG

Provide tools to compare Geant4 simulation results with reference data

- equivalent reference distributions (*for instance, regression testing*)
- experimental measurements
- functions deriving from theoretical calculations or from fits

Vision, URD, Risk List on the web

Powerful architectural design, several goodness-of-fit algorithms etc.

First β -release available

Example: photon attenuation coefficient, vs. NIST reference

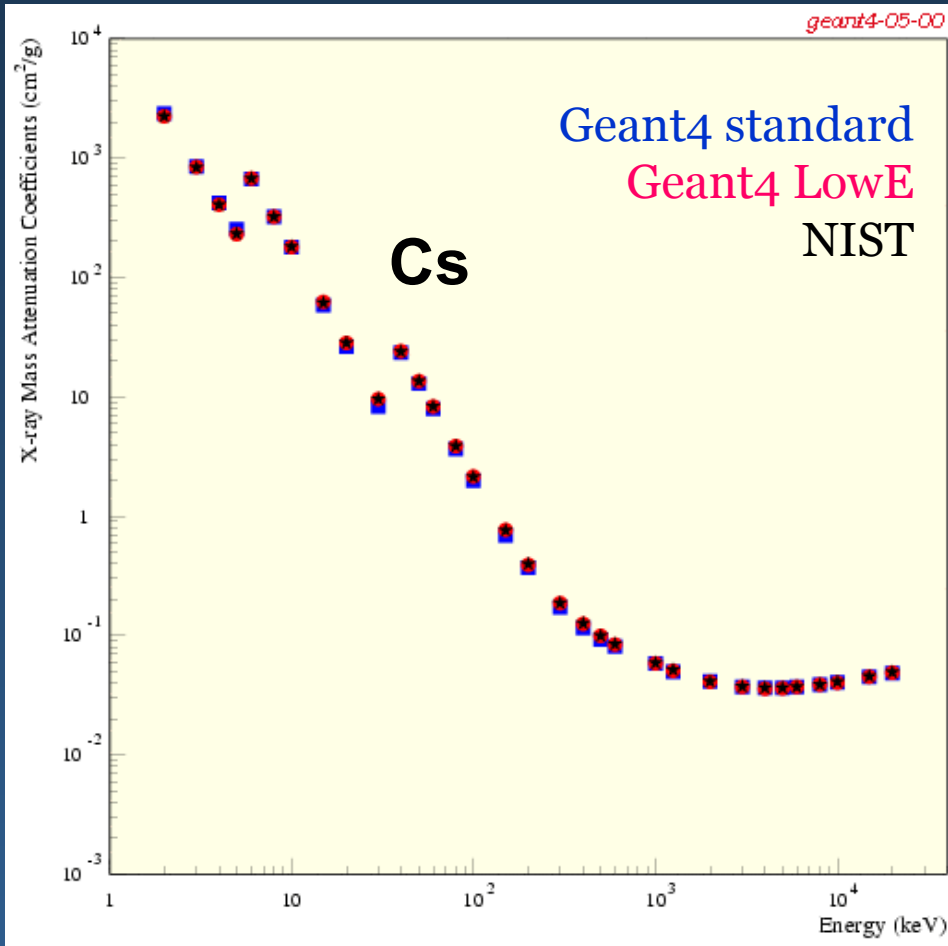

Geant4 LowE

Element	Chi2	P-value	ν	Max Difference %
Al	2.06	1	29	0.035
Cs	4.14	1	34	0.017
Pb	2.074	1	21	0.024
Fe	2.95	1	35	0.023
Water	24.6	0.65	28	0.044
Be	22.3	0.92	33	0.075
Au	3.28	1	32	0.024
Liquid Argon	5.96	0.99	19	0.025

Geant4 standard

Element	Chi2	P-value	ν	Max Difference %
Al	24.2	0.11	17	0.057
Cs	34.4	0.099	25	0.143
Pb	58.05	0.00003	21	0.067
Fe	34.1	0.173	27	0.059
Water	18.9	0.59	21	0.048
Be	25.66	0.59	28	0.079
Au	63.41	0.0002	28	0.088
Liquid Argon	12.1	0.80	17	0.053

Hundreds of plots and tables like these ones
Production at Gran Sasso

powerful developers' layer,
adopting advanced design
techniques
(policy based class design)

powerful statistics content,
adopting state-of-the-art
goodness-of-fit algorithms

- Pearson's χ^2 test
- Kolmogorov Test
- Kolmogorov-Smirnov Test
- Goodman Approximation of K-S test
- Lilliefors test
- Fisz-Cramer-von Mises test
- Cramer-von Mises test
- Anderson-Darling test
- Kuiper test

Statistical comparison: algorithms

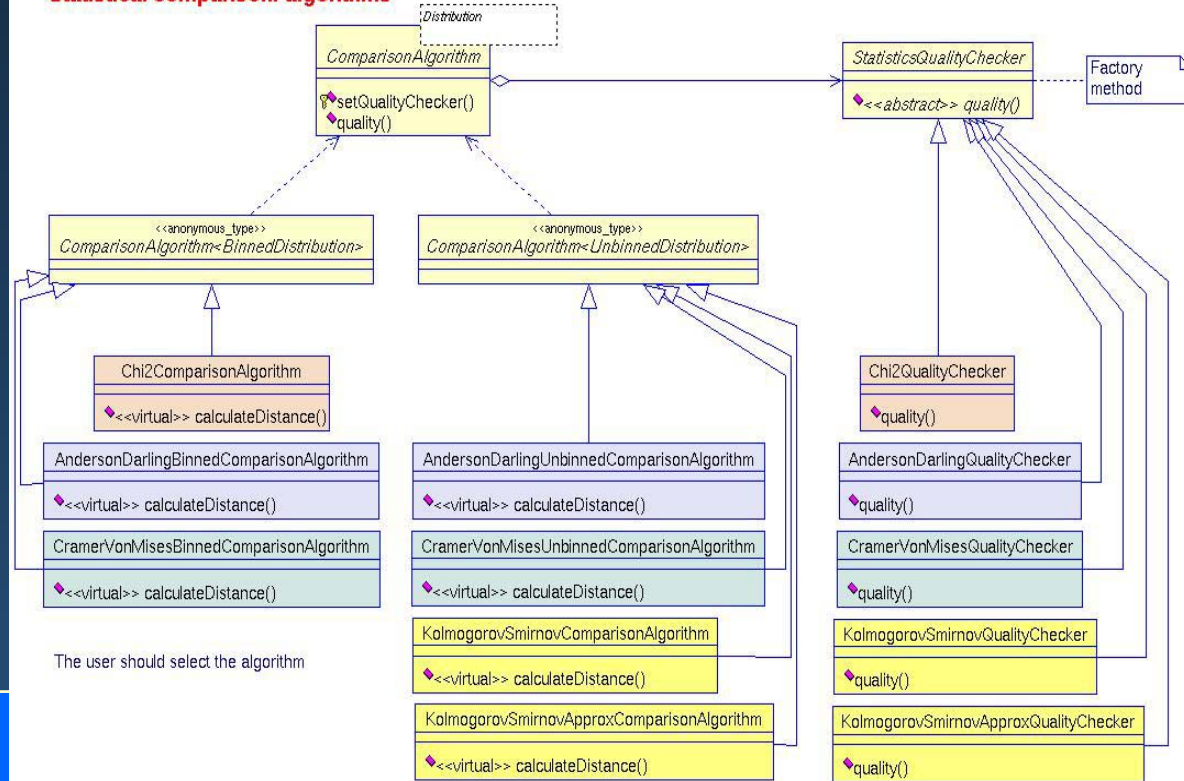

simple, AIDA-based user layer

User layer

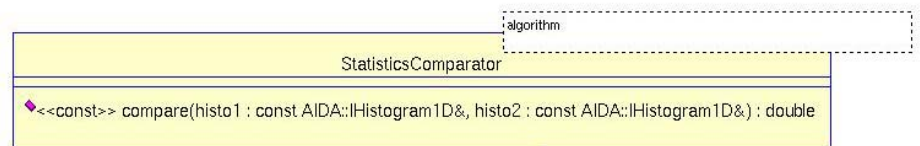

In progress, planned, under discussion...

- “Modular” RunManager
- Abstract Navigator, multiple navigation algorithms
- Various new/improved physics models (*electromagnetic, hadronic*)
- Major re-design of electromagnetic physics in progress
- “Pythonization”
- More event biasing methods
- Error propagation (*à la GEANE*)
- New advanced examples
- Systematic quantitative validation suite of electromagnetic physics
- etc.

(some) Recent (permanent) support activities

● Many support channels

- PRS, HyperNews, direct consultancy of developers, examples (3 levels), web, documentation, introductory seminars, training courses, user workshops...

● Advanced examples

- two examples for LHC-like calorimeters
- one in preparation for LHC-like RICH
- show “clean” design, usage of various physics processes/models
- in collaboration with test-beam groups

● PhysicsLists by use cases

- provide guidance to users through PhysicsLists tailored to specific use cases
- eg.: high energy calorimeter, radiation background etc.

● Heavy daily load of user support

- many users say “thanks”
- many don't...

Geant4 training

Hands-on courses

- Japan (*several*)
- SLAC (*February 2002*)
- Univ. of Salamanca (*July 2002*)
- CERN (*November 2002*)
- ESA (*January 2003*)

Short courses

- Giornate sui Rivelatori, Torino (*2000, 2001, 2002*)
- INFN LNGS (*July 2002*)
- INFN LNS (*December 2002*)

● Geant4 introductory seminars

- at various institutes and laboratories (*Genova, Bologna, Trieste, Udine, Roma2, LNF*)

● Short course at IEEE-NSS 2003 conference

- coordination by Geant4-INFN

● Training programme and experienced trainers available

- invitations welcome...
- help with logistics appreciated

Digression: basic training

- Lack of basic knowledge in “modern” software encountered in the (extensive) experience with Geant4 users (*including LHC experiments*)
 - many physicists do not “speak” C++ (Python, Java) yet
 - hardly any knowledge of the most basic concepts of OO technology
 - C++ = OO (!)
 - UML: “what do all those arrows mean?”
 - OOAD: hardly anybody designs before writing code
 - software process: **what is???**
- Not a criticism, of course
 - but a constructive observation highlighting the need of training
- A practical consequence:
 **many users cannot fully exploit Geant4 capabilities**
- INFN training courses in “modern” software methods and technologies?

Geant4 in Italy

● INFN, but not only...

- CNR, ASI, ENEA, IST (*Ist. Naz. per la Ricerca sul Cancro*), AIRCC (*Ass.ne Italiana per la Ricerca Contro il Cancro*), various hospitals, large industries (*eg. Alenia*), small companies (*eg. RXTEC*), ...
- some of these organizations also provide developers (eg. IST)

● Geant4-INFN developers group

- the largest group in Geant4
- responds to Commissione Calcolo e Reti
- main activities:
 - precision electromagnetic models
 - physics validation: testing tools and data comparisons
 - advanced examples (in collaboration with user groups)
 - integration in distributed computing environments
 - collaboration of frameworks (simulation/analysis)
 - OOAD (a lot!)
 - software process
 - training
- and **a lot of** user support

Geant4 at LNGS

Significant activity in progress

Presentation by S. Parlati at Geant4 Workshop

2 people joined the Collaboration

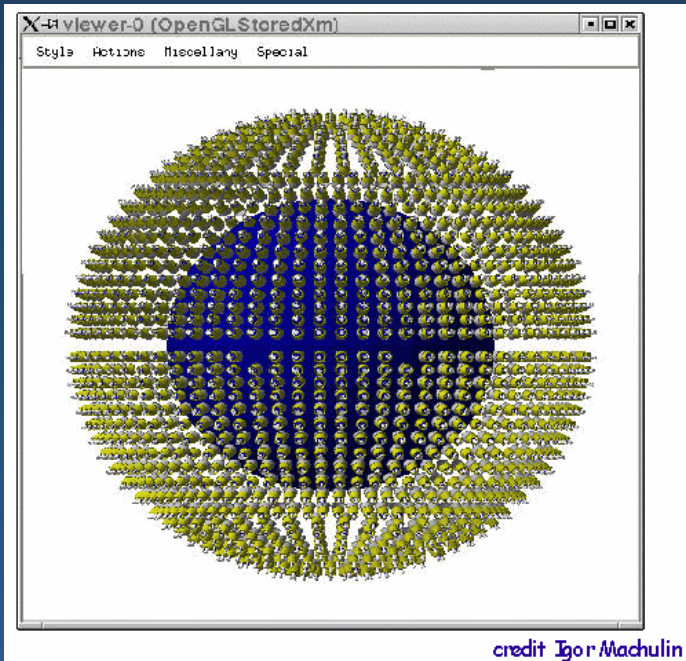

credit Igor Machulin

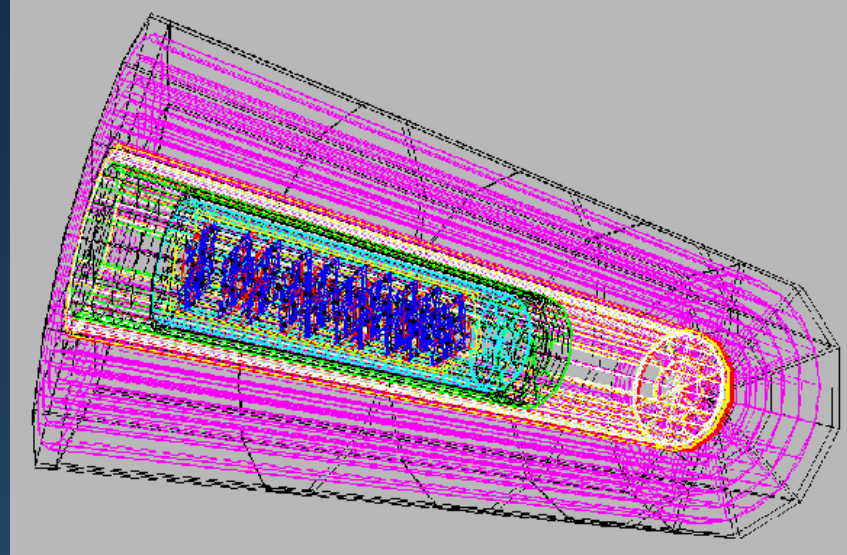

credit Oliviero Cremonesi

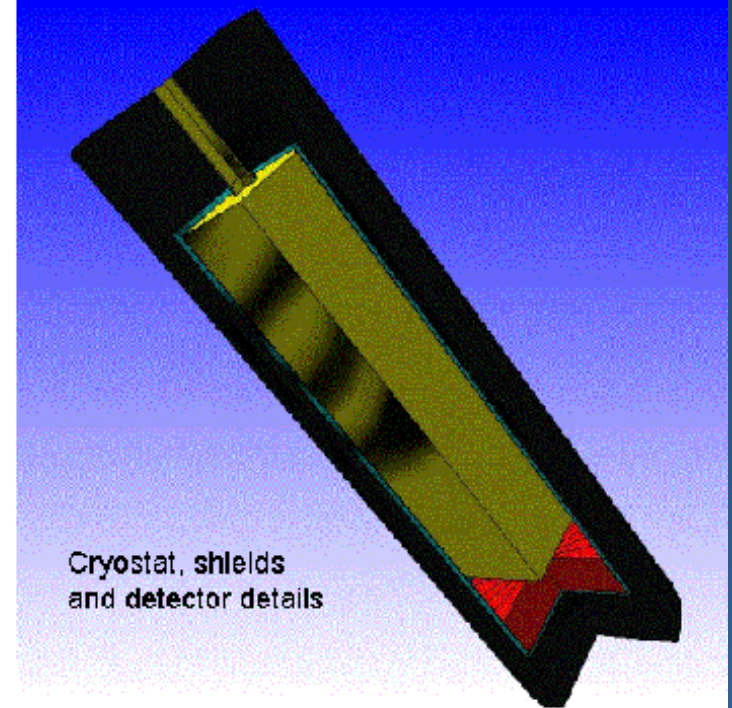
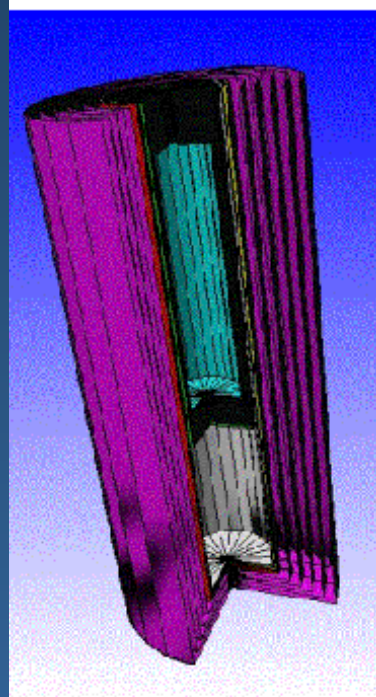

Cryostat, shields
and detector details

Credit Oliviero Cremonesi

No time to mention all on-going
Geant4 astroparticle
applications, not only at LNGS

Maria Grazia Pia, *INFN Genova*

Courtesy of GATE

metabolic therapy

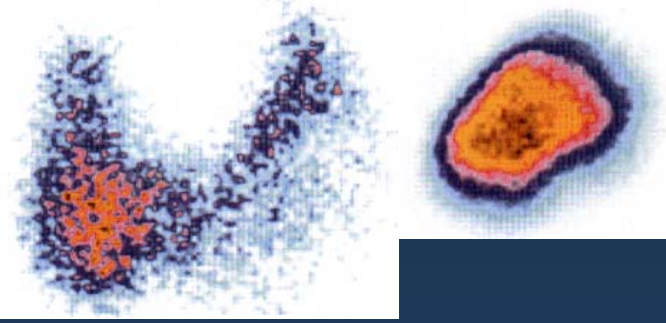

PET

IORT

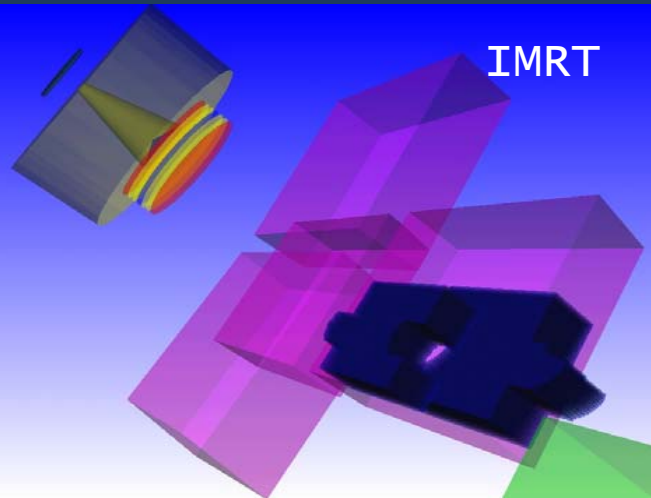
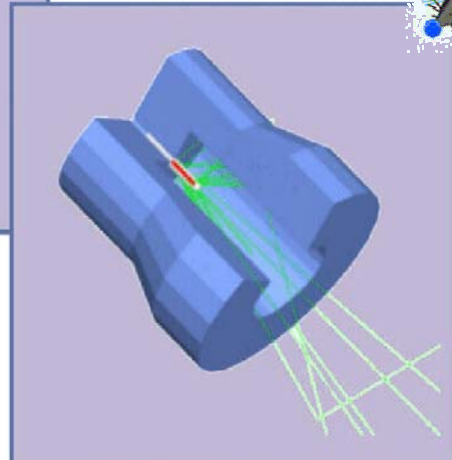
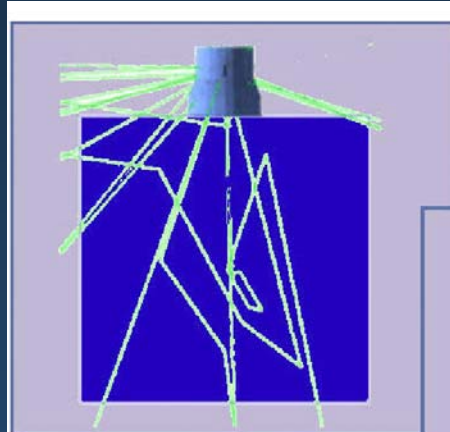

IMRT

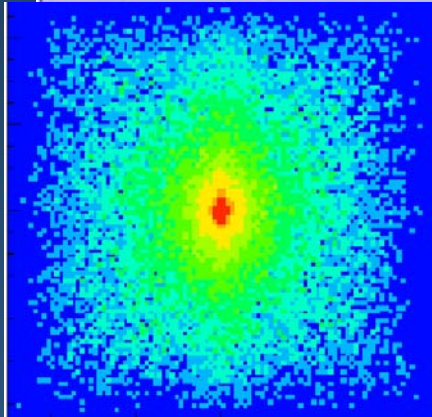

hadrontherapy (CATANA)

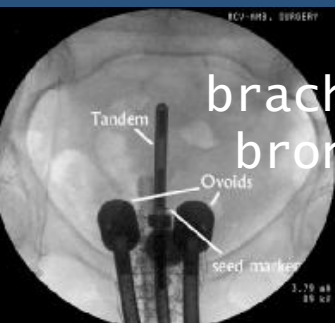

brachytherapy (prostate cancer, bronchi, vagina, uterus cancer, skin cancer etc.)

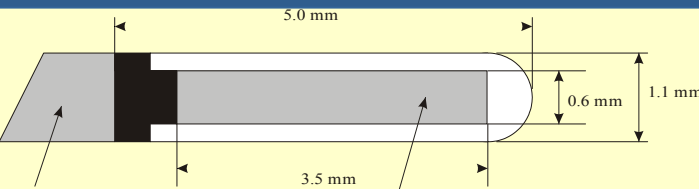

Geant 4

Medical applications

From CT to the GRID

(results in summer conferences)



Technology transfer

Particle physics software aids space and medicine

M.G. Pia and J. Knobloch

“Geant4 is a showcase example of technology transfer from particle physics to other fields such as space and medical science”

Maria Grazia Pia, *INFN Genova*

INTERNATIONAL JOURNAL OF HIGH-ENERGY PHYSICS

CERN COURIER

VOLUME 42 NUMBER 5 June 2002

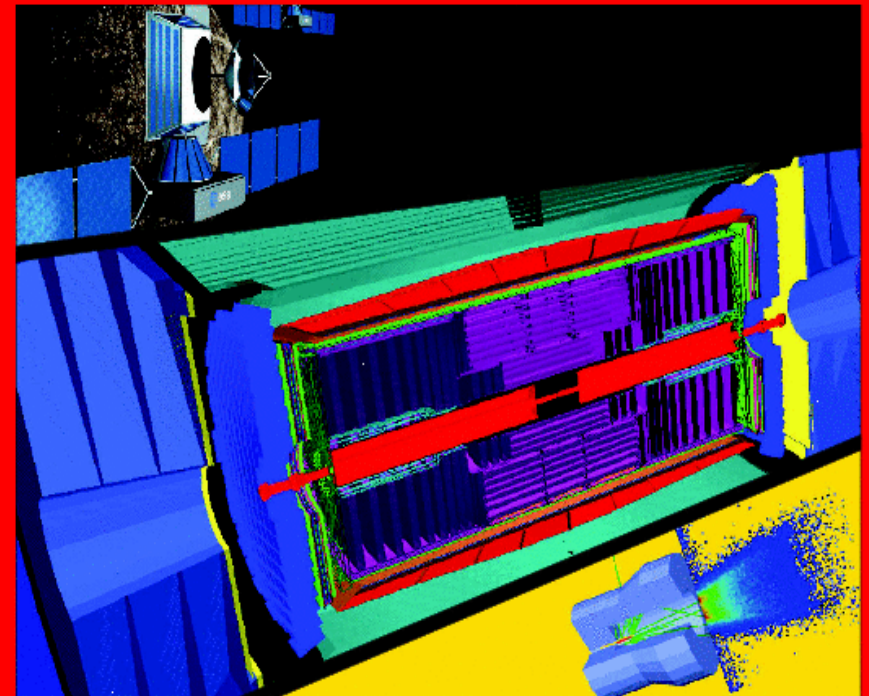

Simulation for physics, space and medicine

<http://www.cerncourier.com>

NEUTRINOS

Sudbury Neutrino Observatory confirms neutrino oscillation p5

TESLA

Electropolishing steers superconducting cavity to new record p10

COSMOPHYSICS

Joint symposium brings CERN, ESA and ESO together p15

Conclusion

- Facts:
 - much old and new functionality of interest to LHC experiments available
 - plenty of validation results both from Geant4 Collaboration and LHC experiments
 - guidance and user support provided by the Geant4 Collaboration
- Of course, all of the above is also true for other experiments, not only for LHC
- Invest into training physicists in the (LHC) experiments to modern software technologies and methods

Proposal to improve communication:

- what about making such Geant4 report to CSN1 a more frequent, regular event?
- one or more “Geant4 advanced examples” in collaboration with LHC INFN groups

Conclusions:

- ✓ Geant4 can simulate relevant features of muon, electron and pion signals in various ATLAS detectors, in most cases better than Geant3;
- ✓ remaining discrepancies, especially for hadrons, are addressed and progress is continuous and measurable;
- ✓ ATLAS can has a huge amount of the right testbeam data for the calorimeters, inner detector modules, and the muon detectors to evaluate the Geant4 physics models in detail;
- ✓ feedback loops to Geant4 team are for most systems established since quite some time; communication is not a problem;
- ✓ Geant4 is definitely becoming a mature and useful product for larga scale detector response simulation!

Nuclear Science Symposium

Medical Imaging Conference

13th International Workshop on Room-Temperature
Semiconductor X- and Gamma-Ray Detectors



2003

Radiation Detectors and Electronics:
Applications in Physics, Industry, Space, Biology, Genetics and Medicine
Physics, Engineering and Mathematical Aspects of Medical Imaging

Plenary Sessions
Oral Presentations
Poster Sessions
Satellite Workshops
Short Courses
Industrial Exhibits
Companion Program

Abstract Submission Deadlines:
NSS & MIC: May 16, 2003
RTSD Workshop: June 27, 2003

October 19-25, 2003
Portland, Oregon, USA
DoubleTree Hotel – Hayden Island Complex

Software & Computing session
introduced for the first time into
IEEE NSS

Convenors: J. Knobloch and M.G. Pia

+

IEEE NSS/MIC Short Course
on Geant4

Organizer: M.G. Pia

Please send abstracts!

Deadline for abstract submission:
16 May