

Monte Carlo simulation with Geant4 for verification of rotational total skin electron therapy (TSET)

Christina Jarlskog

Department of Radiation Physics

Lund University, Malmö University Hospital (UMAS)

Collaborators:

Lena Wittgren, Sven Bäck, Joakim Medin (UMAS)

and

Erik Traneus (Nucletron)

Rotational total skin irradiation at UMAS



- Varian Clinac 2100 C/D
- 6 MeV electrons
- treatment SSD = 250 cm
- 36 cm x 36 cm field
- rotating platform

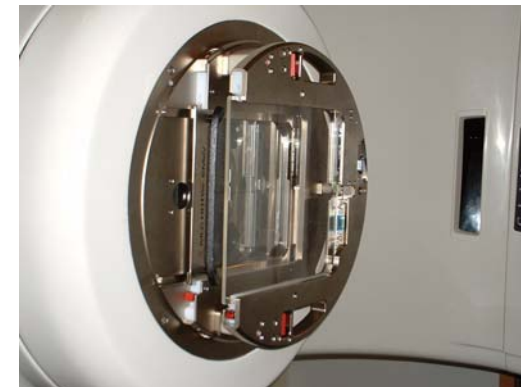

Aim of this study

- What is the absorbed dose in one rotation...?
- measure dose rate in a stationary geometry
- use the MC to relate to the treatment geometry

$$R = \frac{\text{dose in a stationary geometry for 100 MU}}{\text{dose in one rotation}}$$

$$R_{MC} = \frac{100 D_{MC}^{stationary}}{270 D_{MC}^{rotation}}$$

Simulated geometry

- beam incidence angle wrt phantom x-axis: $0^\circ \leq \vartheta < 360^\circ$
- the simulation scores energy deposition along x ('z')

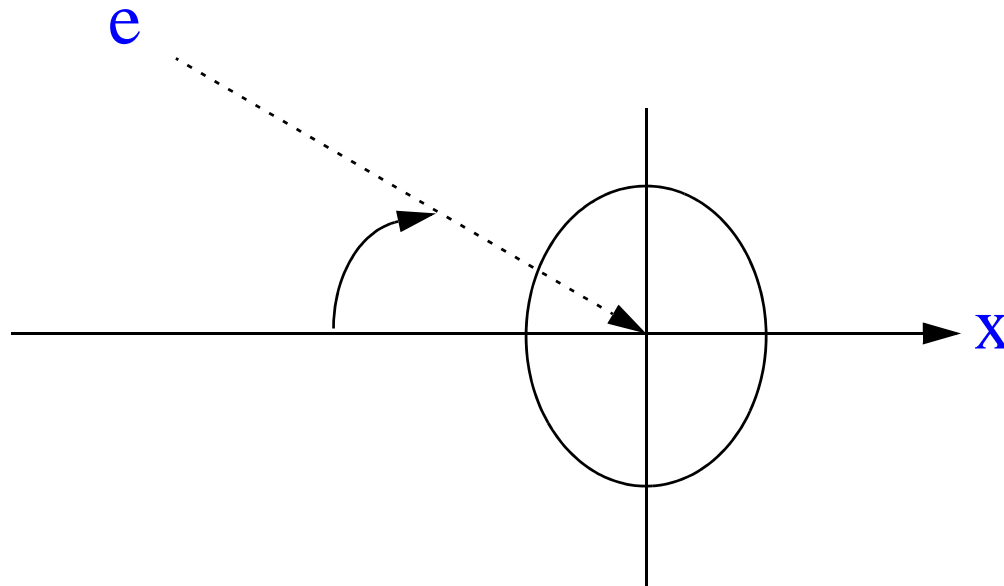

The rotational depth dose distribution

$$D_{MC}^{rotation} = \int_{\vartheta} D(z, \vartheta) d\vartheta$$

$$D_{MC}^{rotation} \cong w_{0^\circ} D_{MC}^{\vartheta=0^\circ} + 2 \sum_{\vartheta} w_{\vartheta} D_{MC}^{0^\circ < \vartheta \leq 90^\circ} + 2 \sum_{\vartheta} w_{\vartheta} D_{MC}^{90^\circ < \vartheta < 180^\circ} + w_{180^\circ} D_{MC}^{\vartheta=180^\circ}$$

$$D_{MC}^{rotation} \cong w \left(D_{MC}^{\vartheta=0^\circ} + 2 \sum_{\vartheta} D_{MC}^{0^\circ < \vartheta \leq 90^\circ} \right)$$

$$w = \frac{\Delta\vartheta}{360^\circ} \quad , \quad \Delta\vartheta = 5^\circ, 10^\circ$$

The simulation

- geometry: homogeneous water phantom
- physics models: standard em and low-energy em
- production thresholds:
 - air: 10 keV for photons/electrons
 - water: 10 keV photons, 100 keV/10 keV
- maximum allowed step length: not set

SteppingAction

- score energy distributions
- grid of 0.5 mm along x-axis
- scoring volume: cylinder of radius r (not built in the geometry)
- check if step is in a water volume
- check if step is within/crossing cylinder
- find energy deposition in scoring volume
- split energy deposition in the grid
- fill energy histogram

Primary Generation: 'OTP electrons'

- parametrization of a Varian 2100C/D accelerator with 25x25 applicator
- virtual source position: 85 cm upstream the isocenter
- exit phase space plane: 5 cm upstream the isocenter
- field size 36 cm x 36 cm (yz plane)
- y and z coordinates from flat distribution
- direction cosines corrected for scattering in accelerator
- correction independent of radial displacement
- only direct electrons simulated
- energy sampled from OTP spectrum

OTP energy spectrum

- extracted for PDD measured at SSD = 100 cm: $D_{meas}(z)$
- precalculated $D_{mono}(E, z)$ with VMC++
- E is the kinetic energy of the primary electrons
- assuming an energy spectrum $F(E)$ with unknown constants
- PDD is given by: $D(z) = D_{\gamma}(z) + \int F(E)D_{mono}(E, z)dE$
- the unknown constants in $F(E)$ are calculated by fitting
- $D_{meas}(z)$ by $D(z)$

Fitted PDD

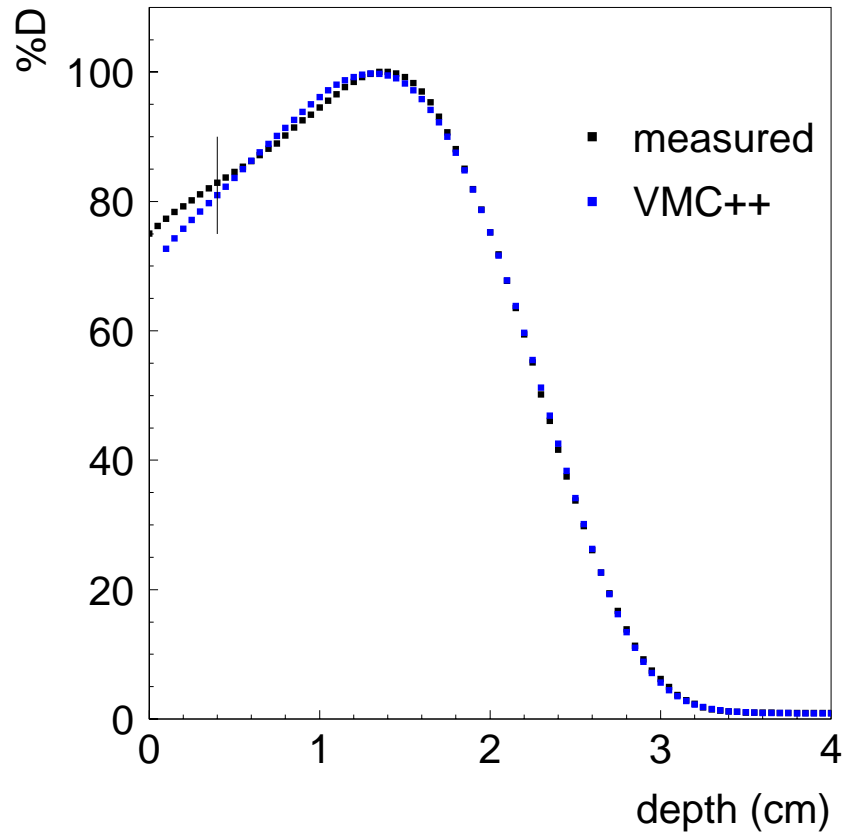

the distribution is fitted
for $z > 4$ mm to neglect
low-energy electrons
that deposit energy
close to the surface of
the phantom

Kinetic energy of primary electrons

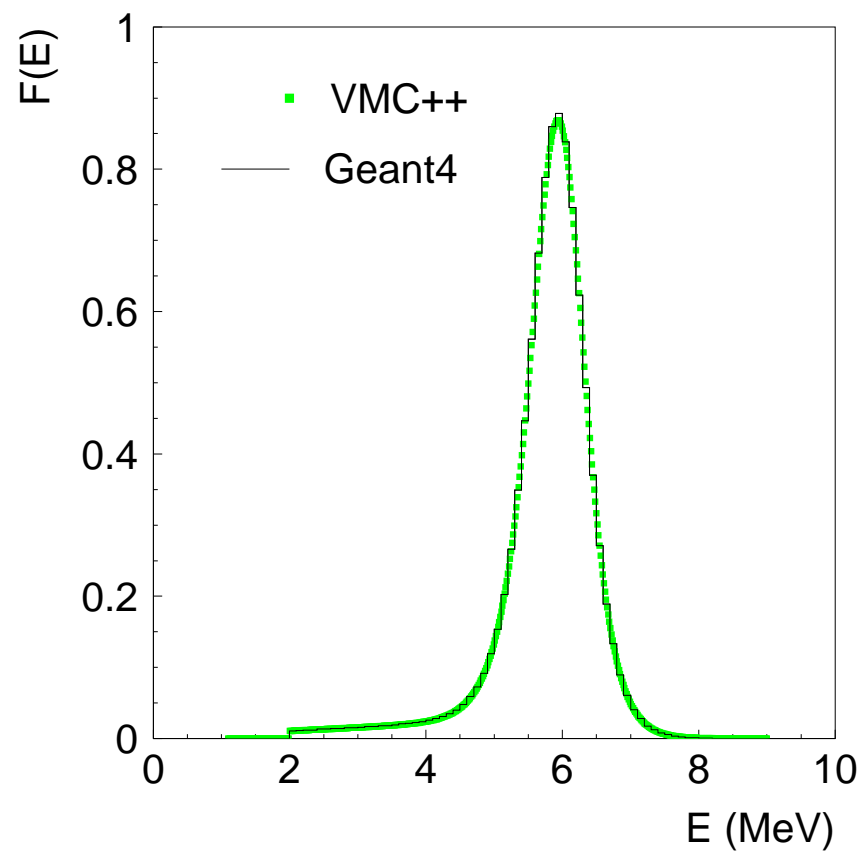

Overview of the simulations (uniform thresholds)

Stationary geometries ($r = 2$ cm, cubic phantom 50 cm side):

- SSD = 100 cm, standard em physics
- SSD = 100 cm, low-energy em physics
- SSD = 250 cm, low-energy em physics

Rotational geometries (SSD = 250 cm, low-energy em physics):

- test runs: $r = ?$, $\Delta\vartheta = ?$, $N = ?$ if $\sigma_{R_{MC}} \approx 2\%$
ellipsoid phantom 35 cm in x, 50 cm in z, 25 cm in y
 - run 1: $r = 2$ cm, $\Delta\vartheta = 10^\circ$ (10 M events/angle)
 - run 2: $r = 0.5$ cm, $\Delta\vartheta = 10^\circ$ (100 M events/angle)
 - run 3: $r = 0.5$ cm, $\Delta\vartheta = 5^\circ$ (100 M events/angle)
- ellipsoid phantom 20 cm in x, 40 cm in z, 25 cm in y
- cylindrical phantom 30 cm diameter, 25 cm height

Comparison MC/measurement at SSD=100 cm

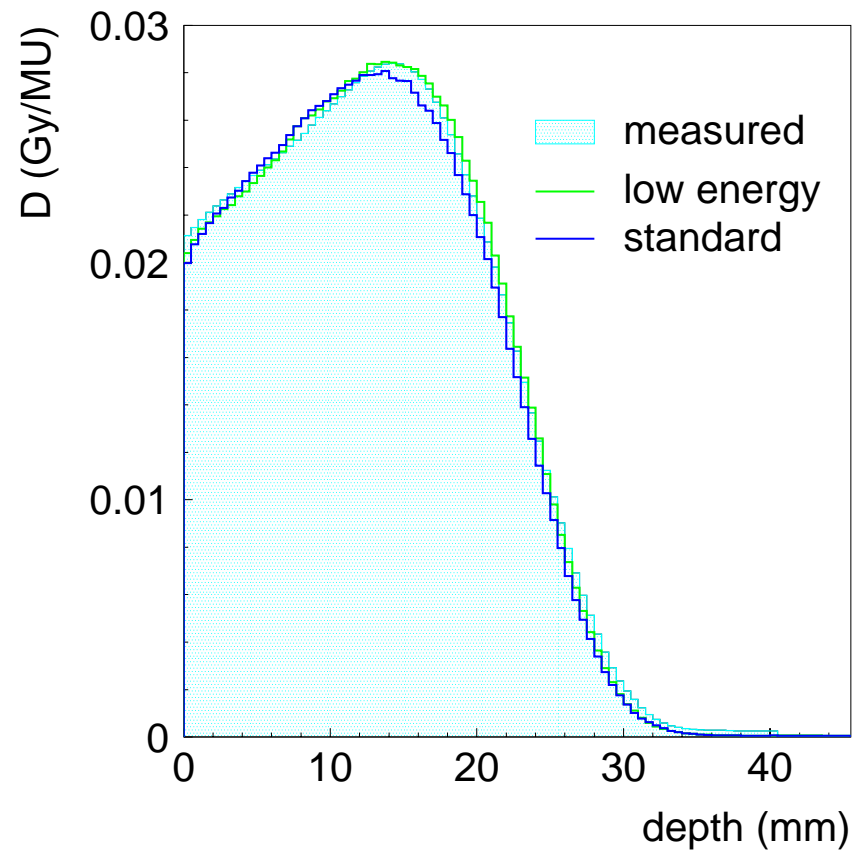

Comparison MC/measurement at SSD=250 cm

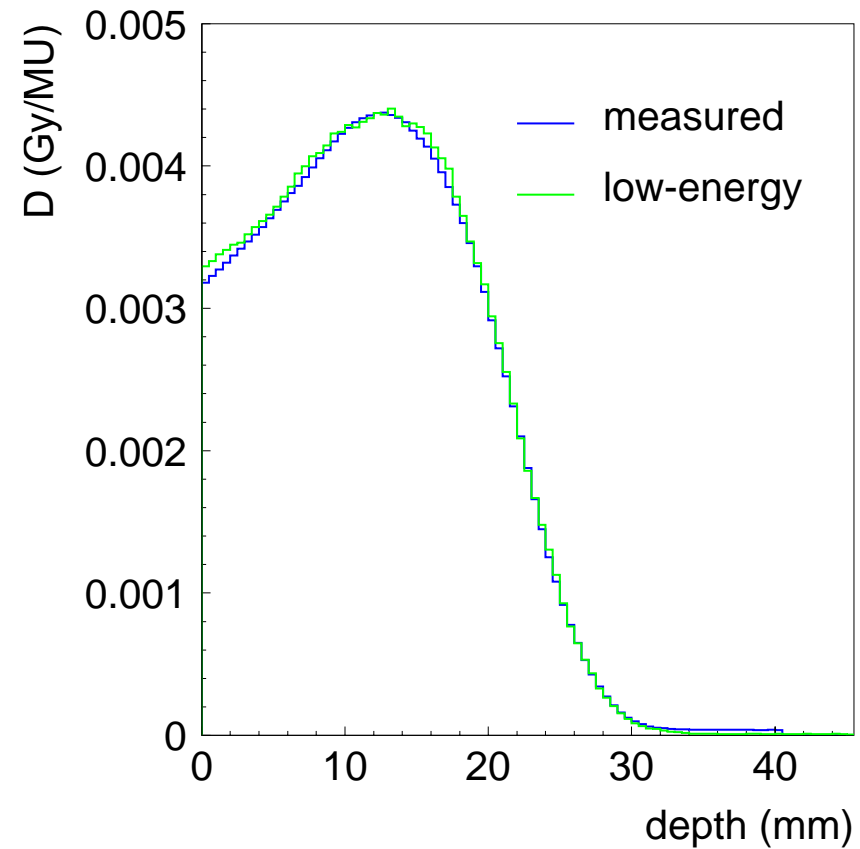

Results of test run 1 ($r = 2$ cm, $\Delta\vartheta = 10^\circ$)

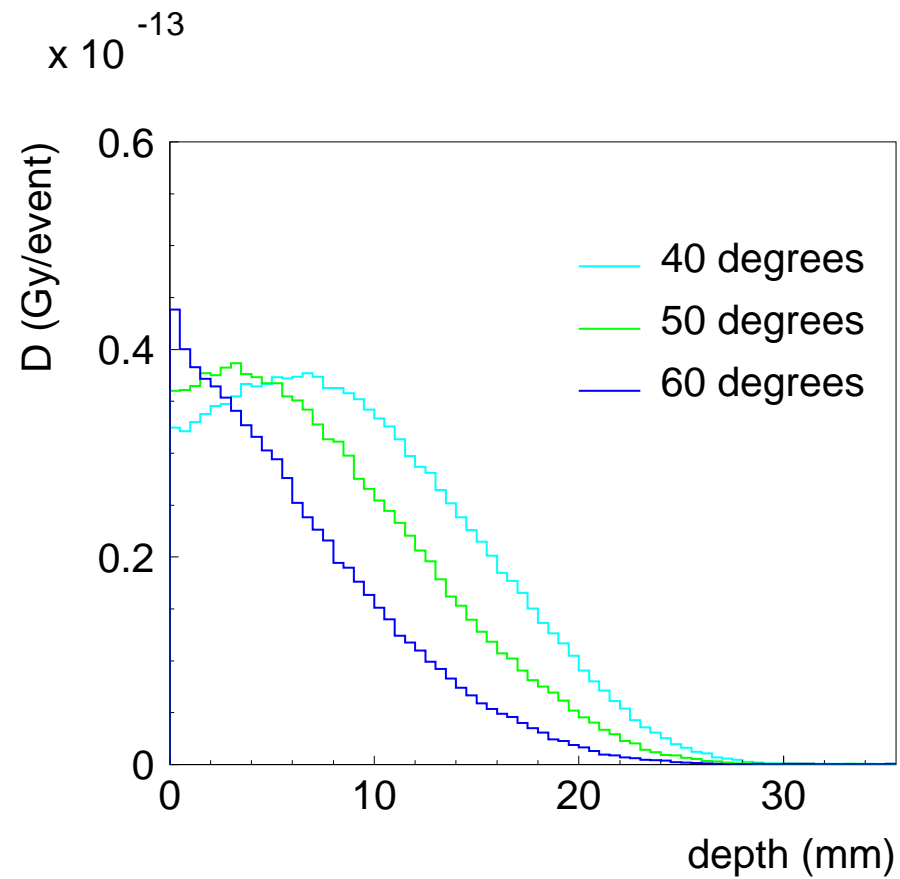
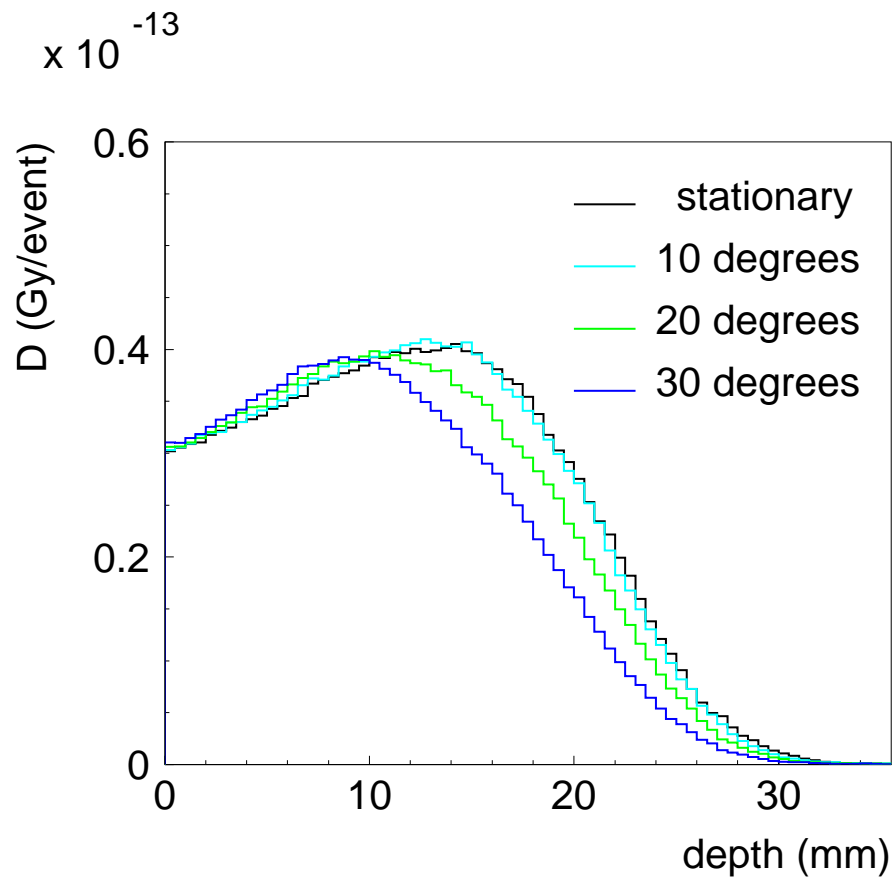

Results of test run 1 ($r = 2$ cm, $\Delta\vartheta = 10^\circ$)

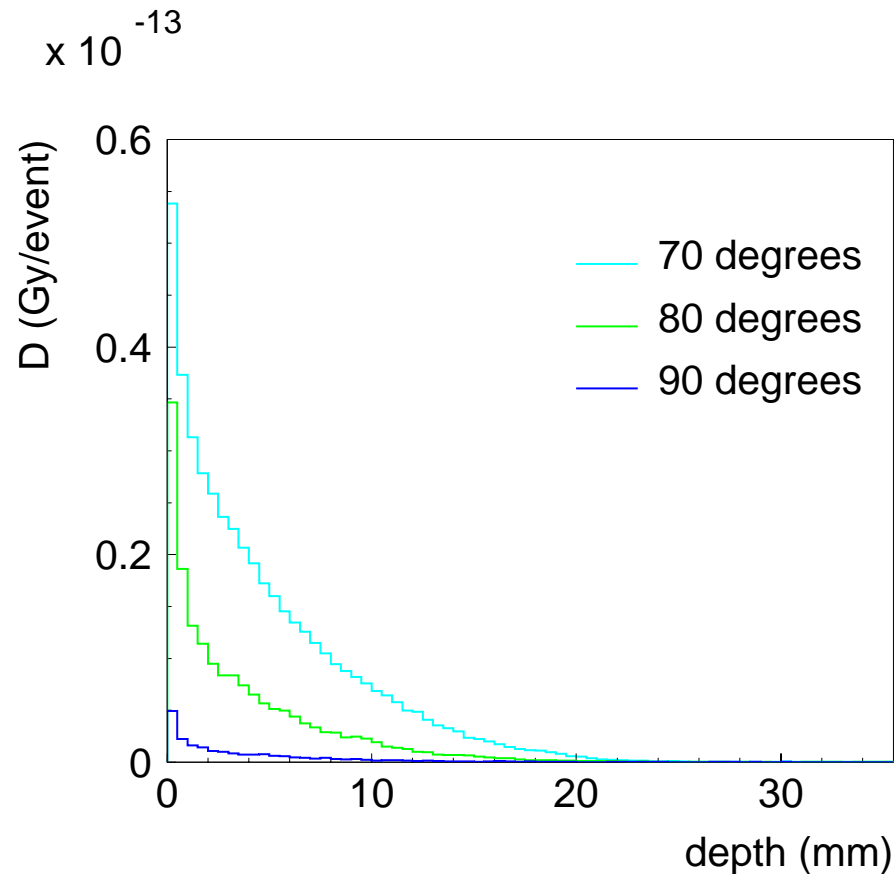

is the surface dose
too high at large
beam angles?

Results of test run 1 ($r = 2$ cm, $\Delta\vartheta = 10^\circ$)

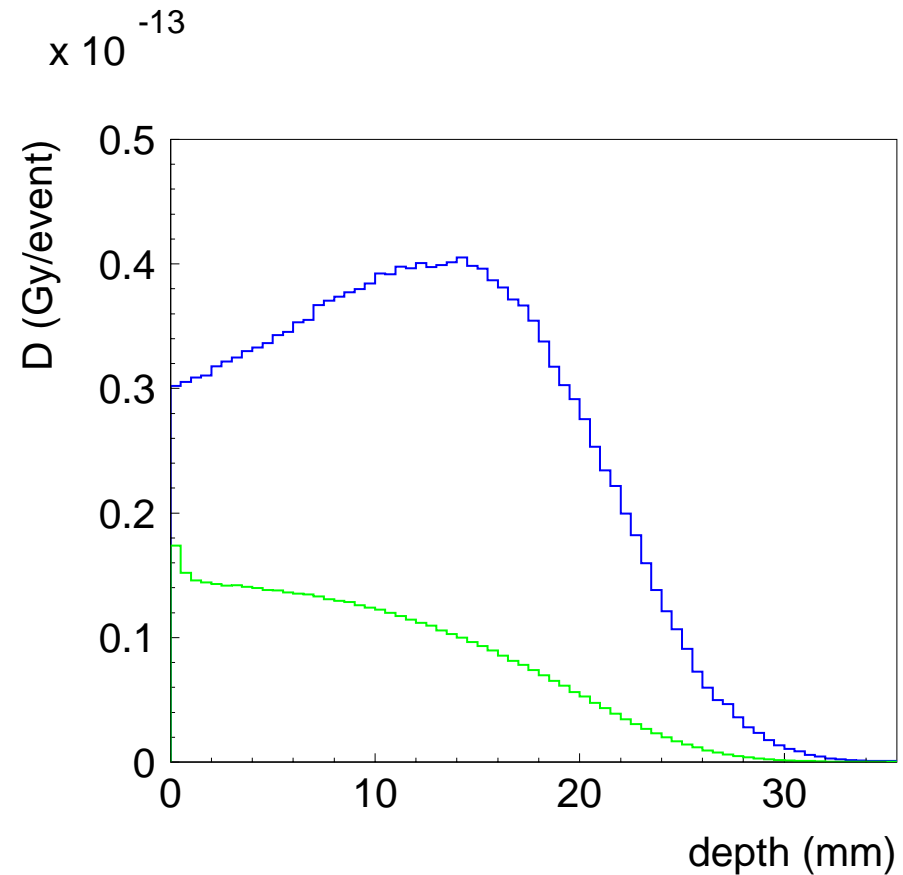

Results of test run 1 ($r = 2$ cm, $\Delta\vartheta = 10^\circ$)

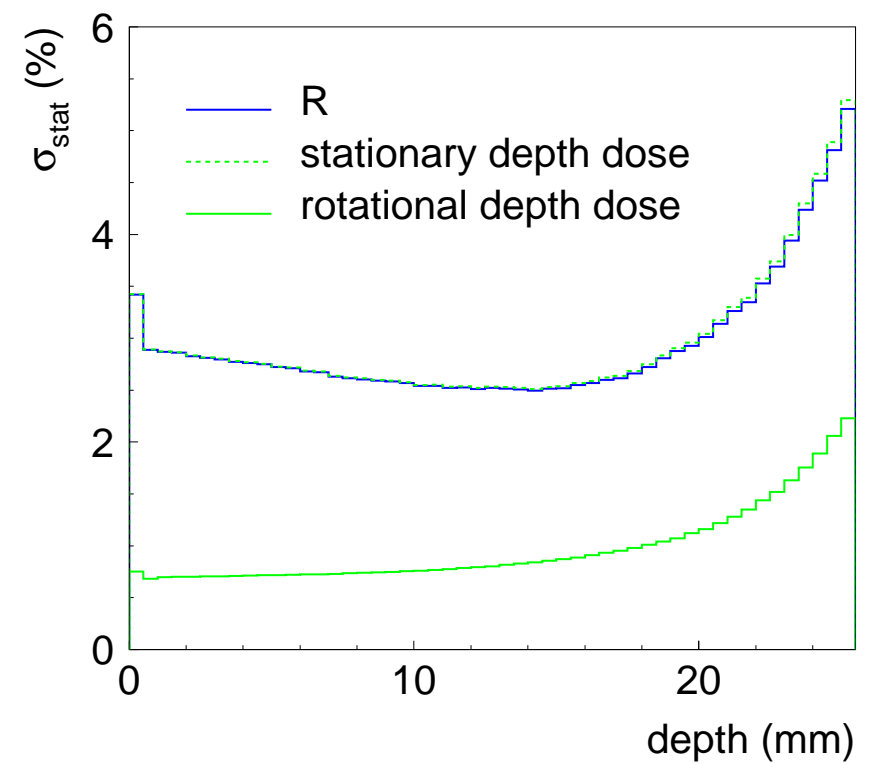
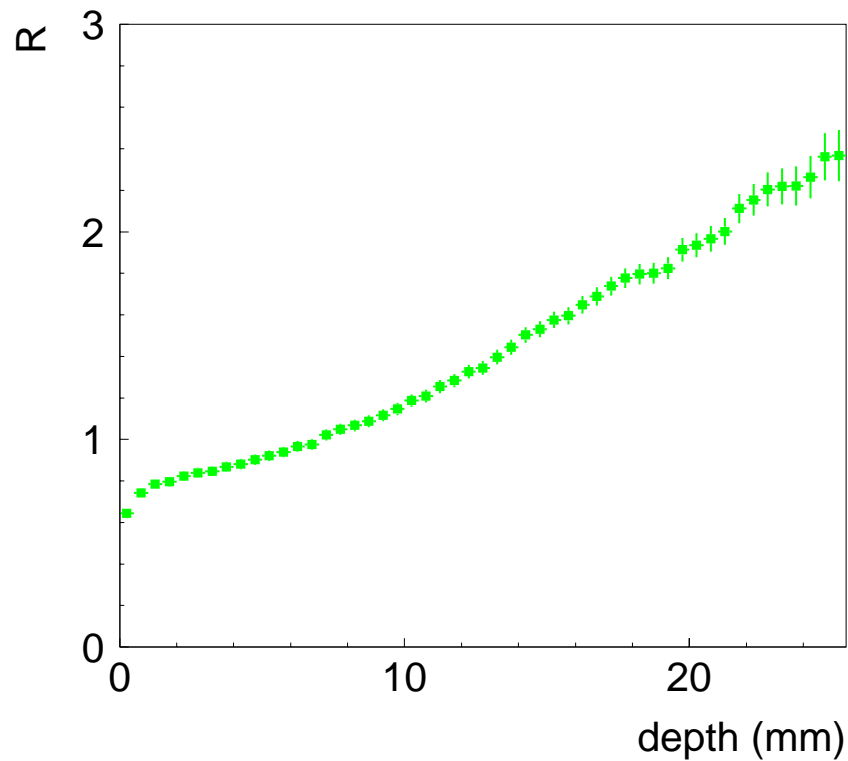

Test runs: difference in stationary depth dose

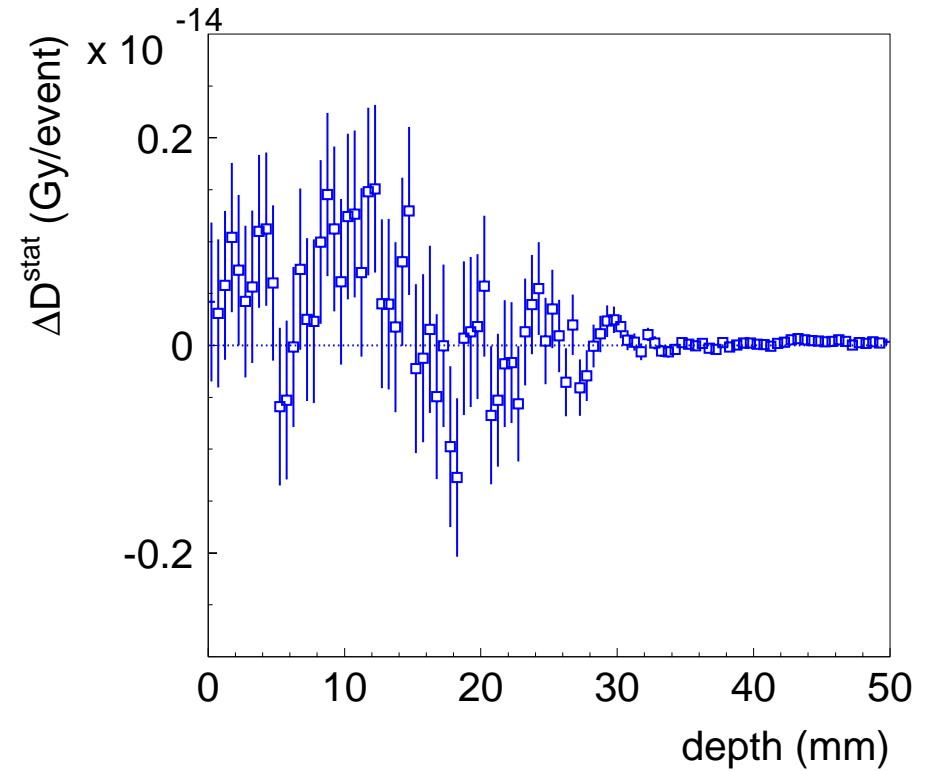
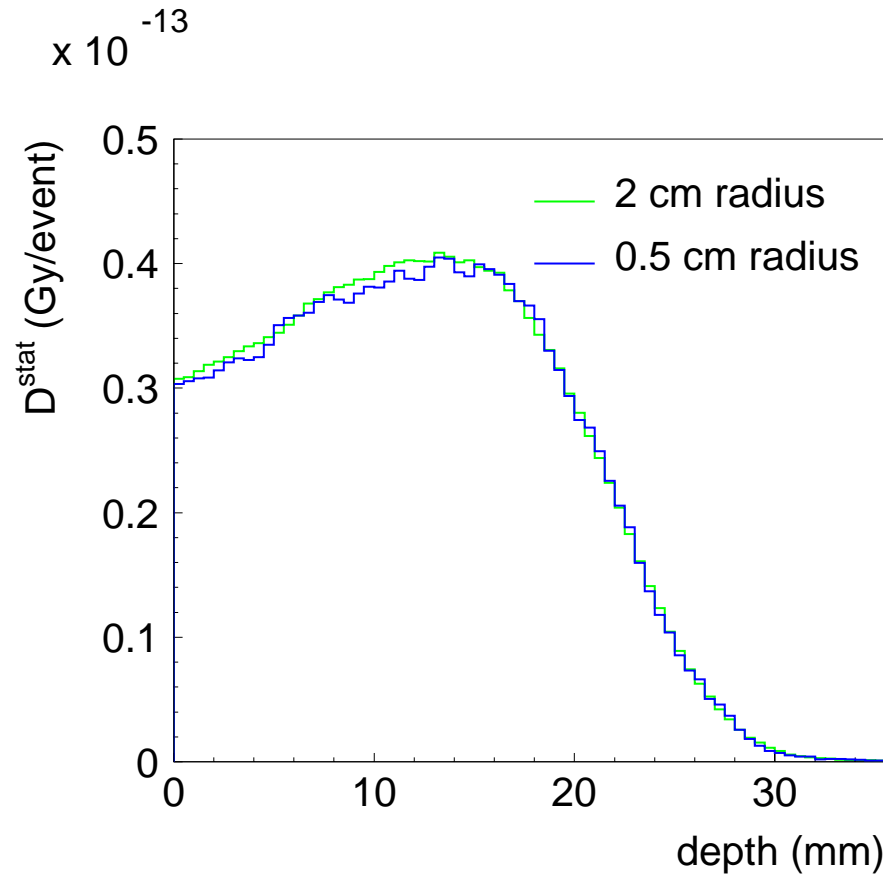

Test runs: difference in rotational depth dose

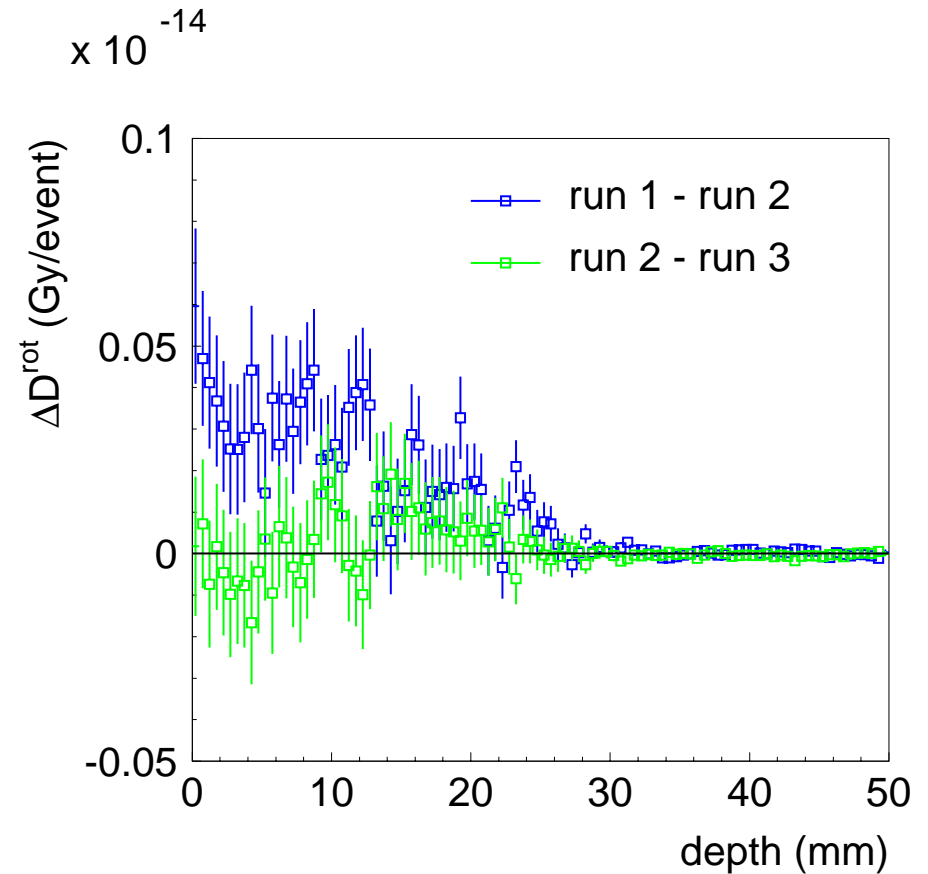
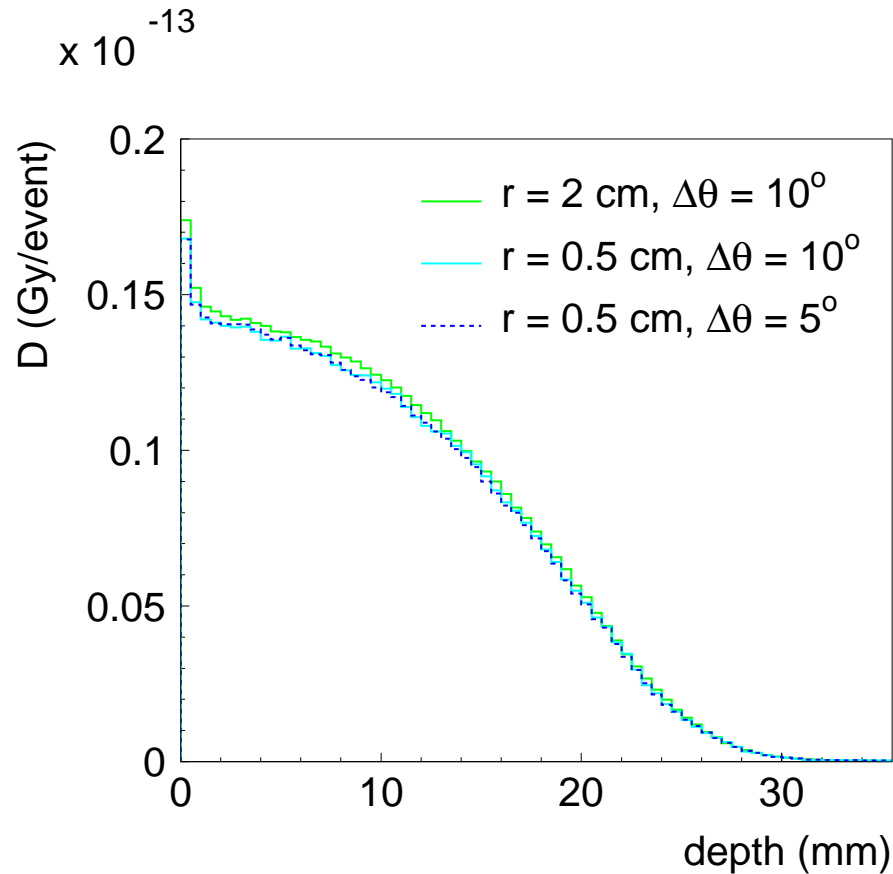

Test runs: difference in R

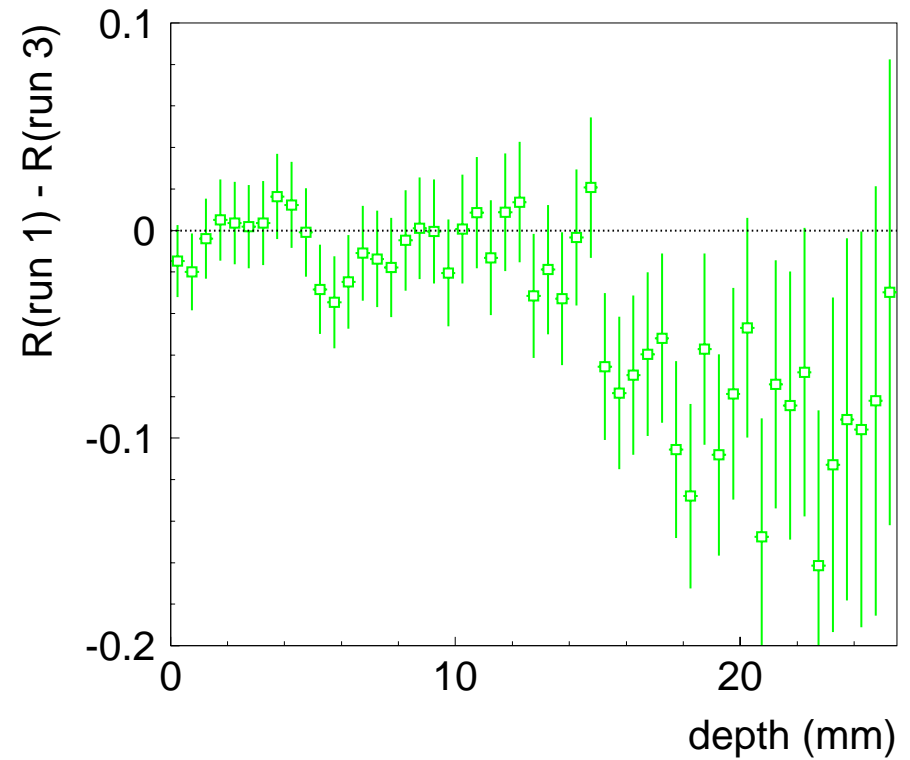
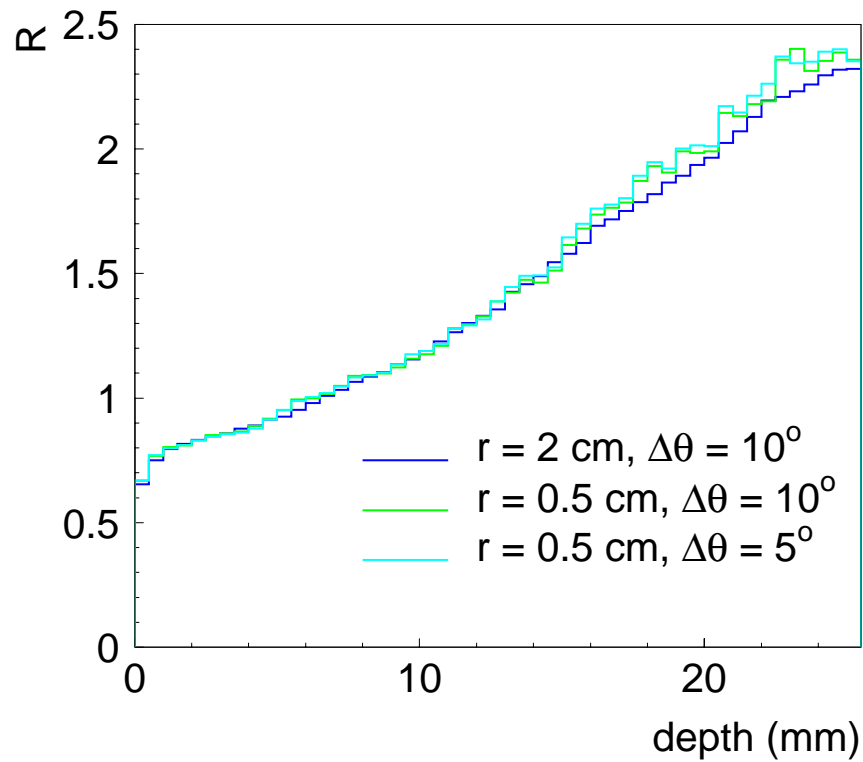

Simulation parameters

Subsequent simulations were run with the following parameters:

- a scoring volume radius of 2 cm
- a step $\Delta\vartheta = 10^\circ$ in angle of beam incidence
- 10 million events per angle for $\vartheta > 0^\circ$
- 40 million events for $\vartheta = 0^\circ$

Dependence on phantom cross-section

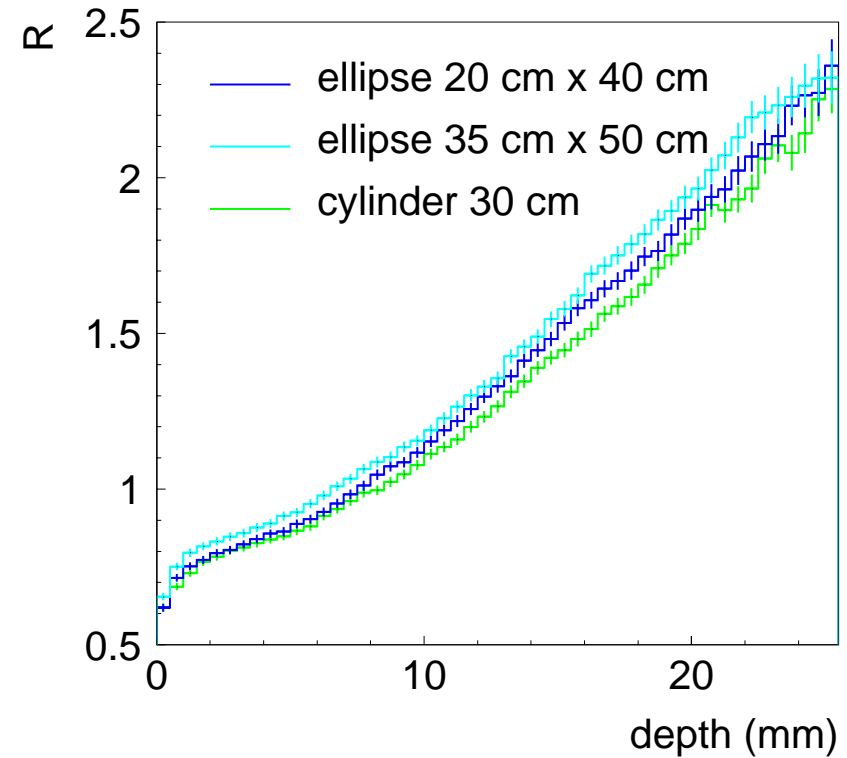
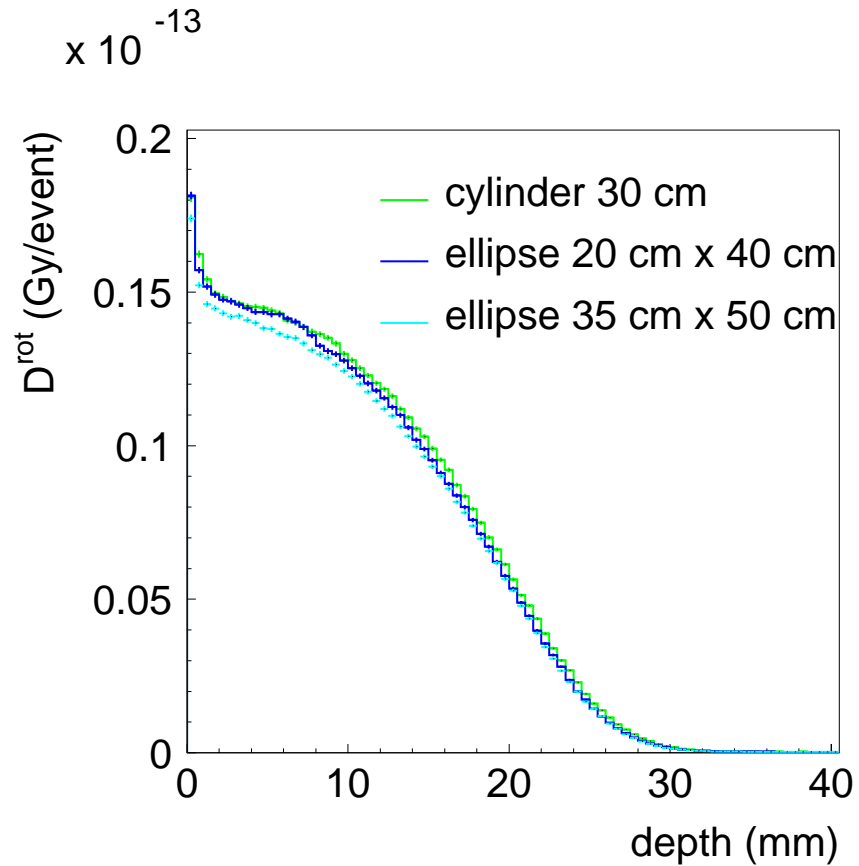

Thresholds by region for the cylindrical geometry

- inner phantom with 10 keV threshold for electrons:
 - outer radius: 15 cm, inner radius: 11 cm
 - $\Delta\phi = 30^\circ$

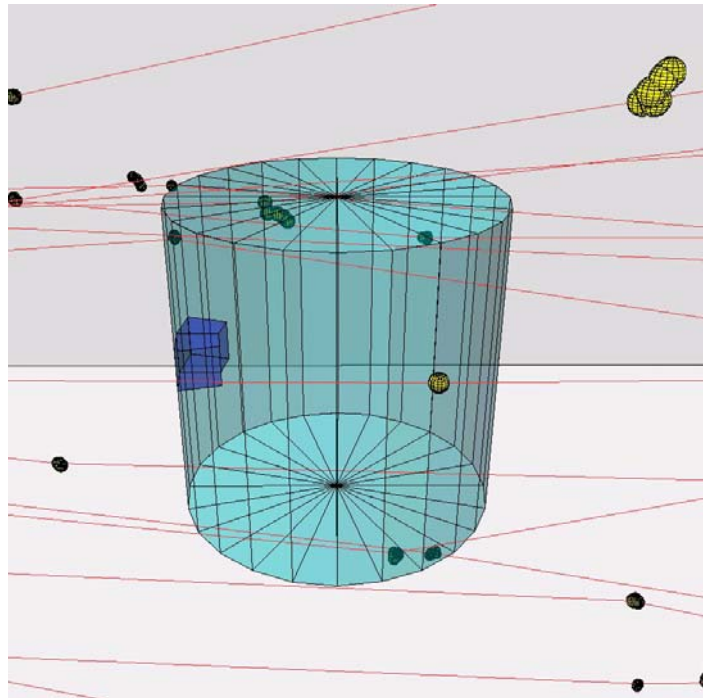

Threshold dependence at SSD = 250 cm

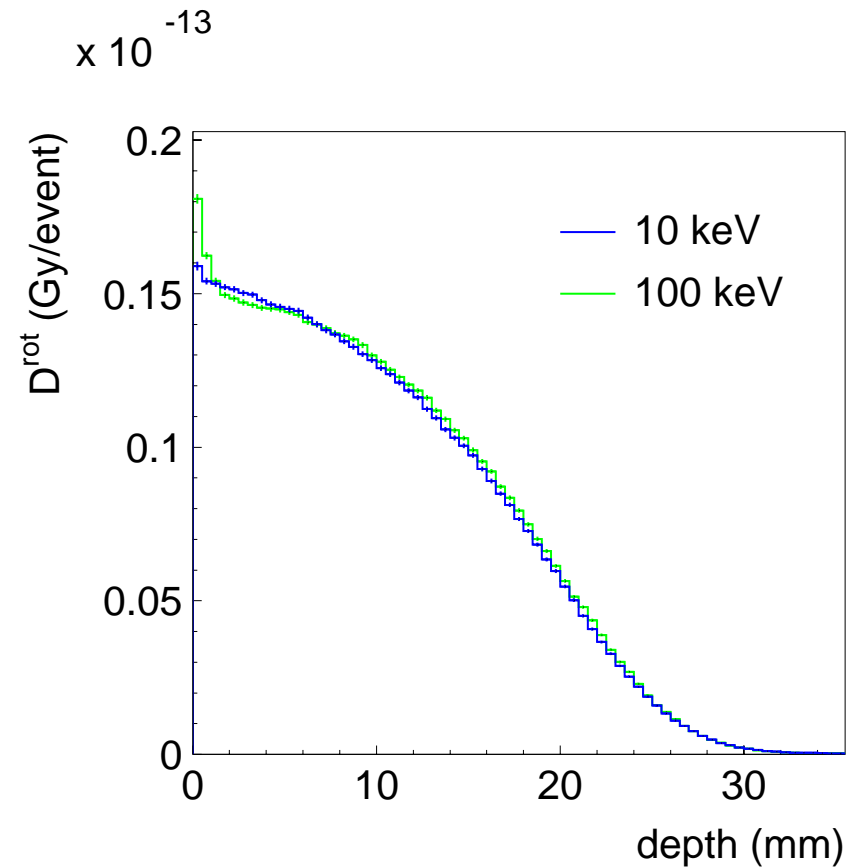
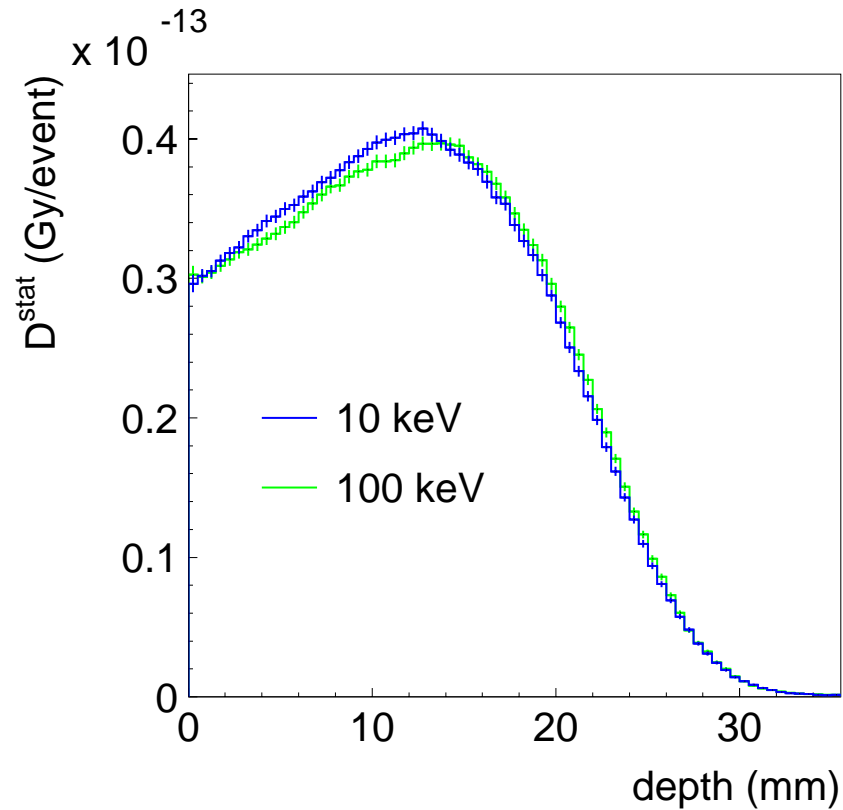

Threshold dependence at SSD = 250 cm

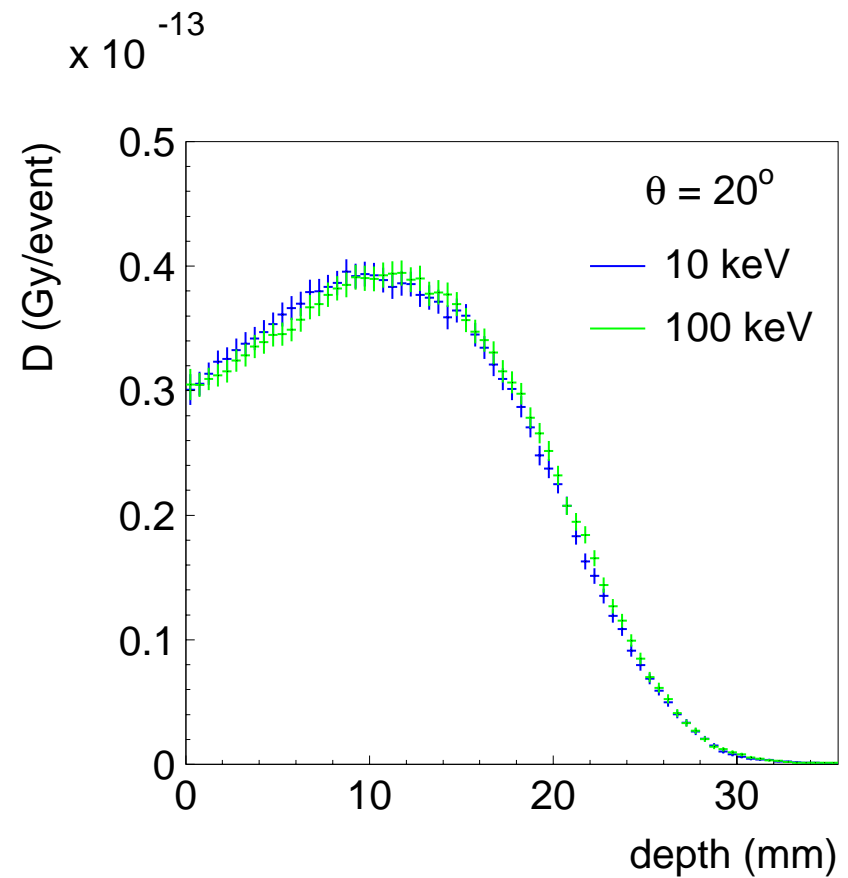
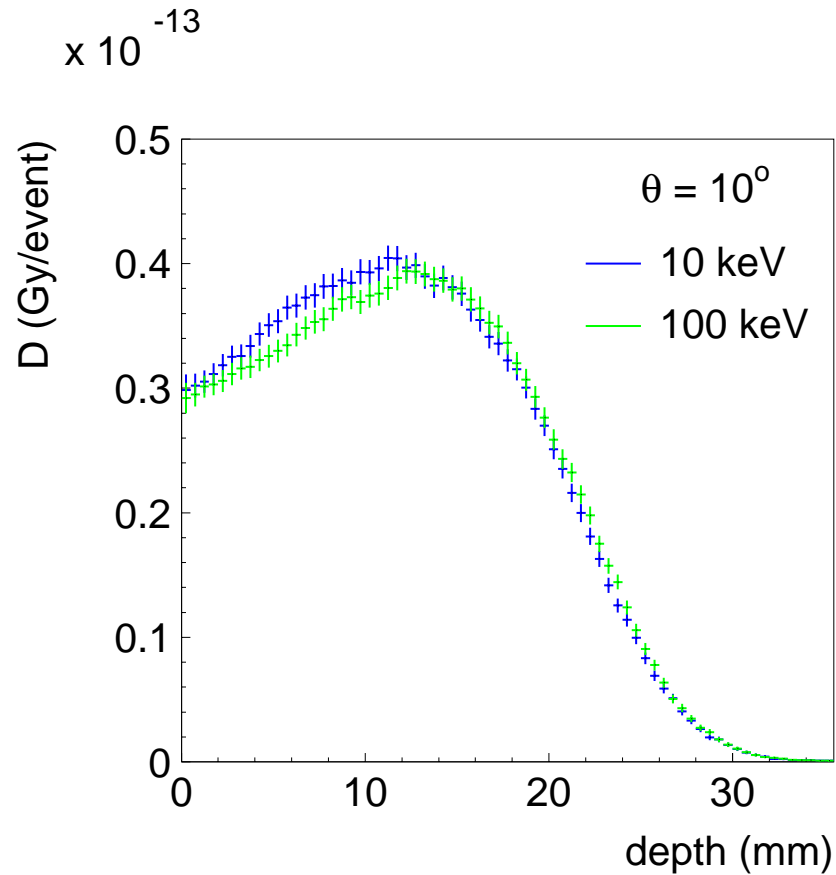

Threshold dependence at SSD = 250 cm

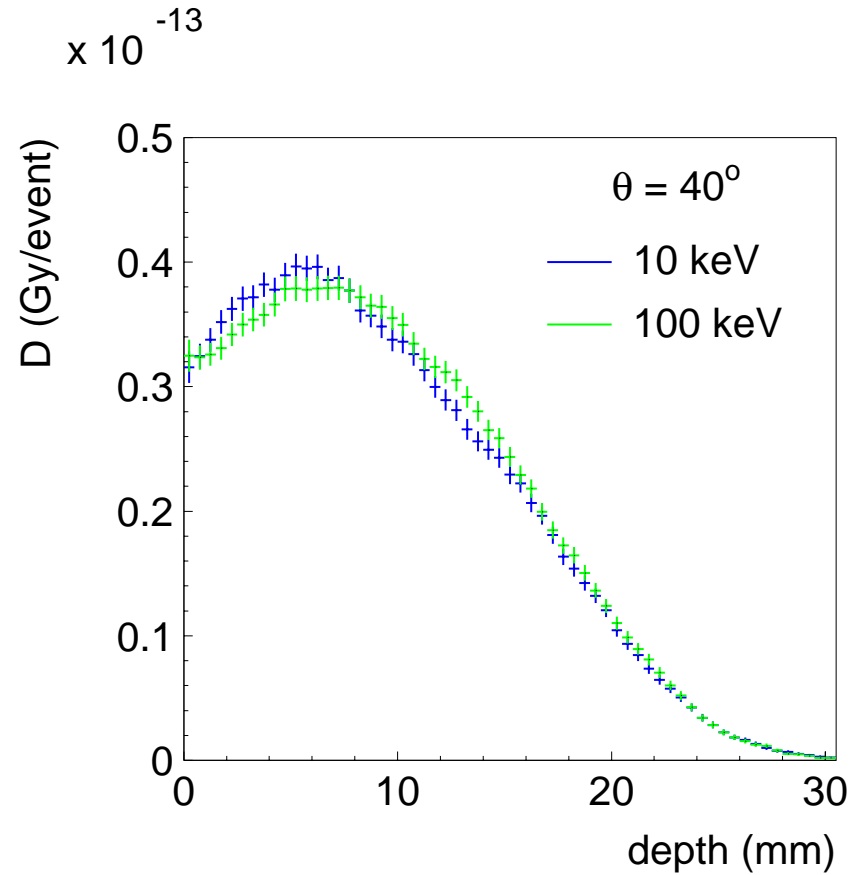
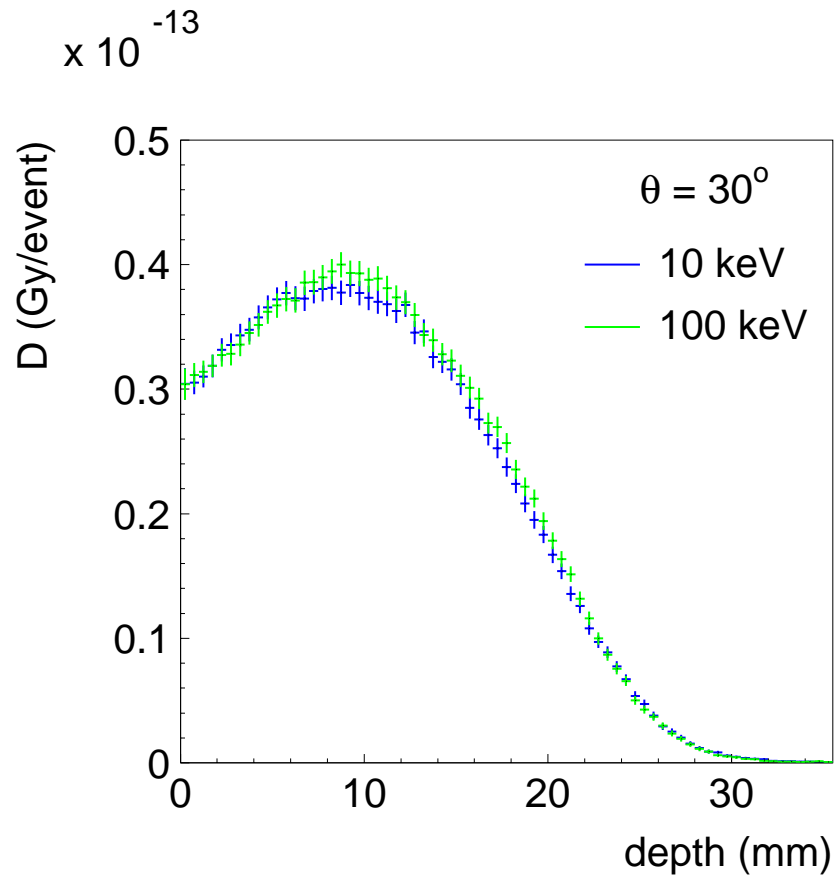

Threshold dependence at SSD = 250 cm

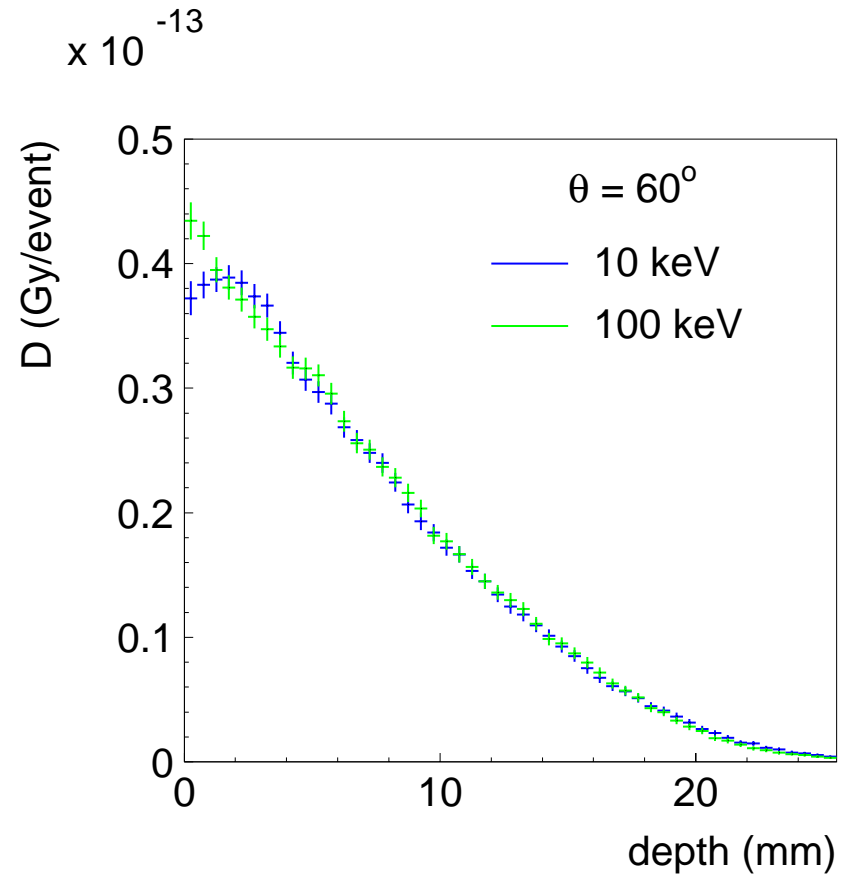
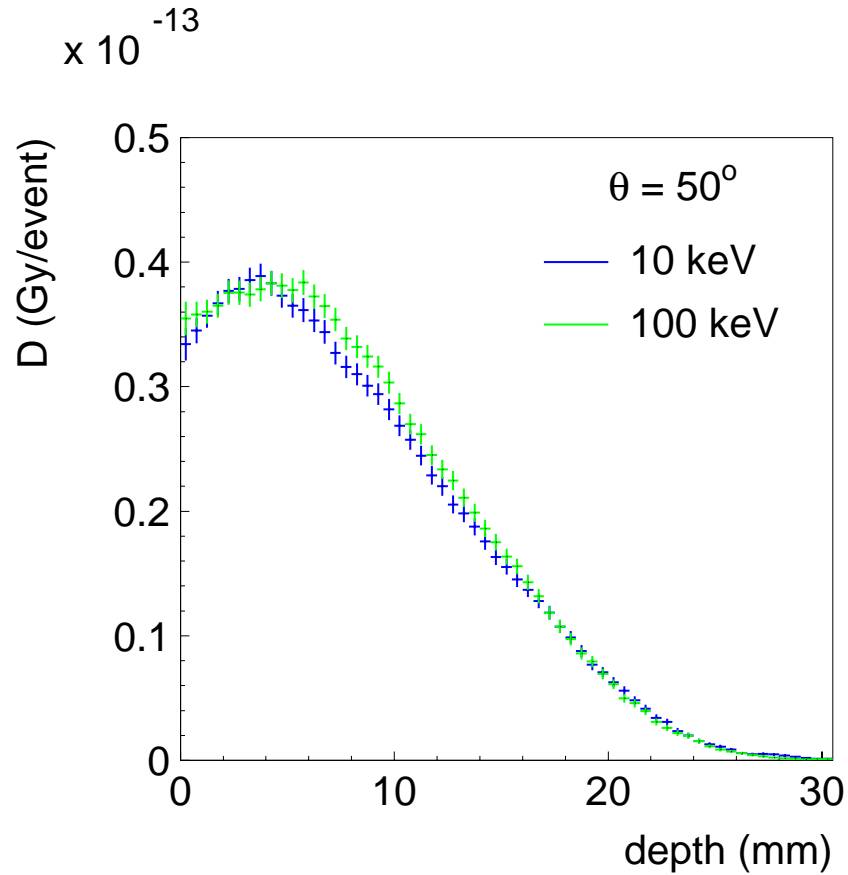

Threshold dependence at SSD = 250 cm

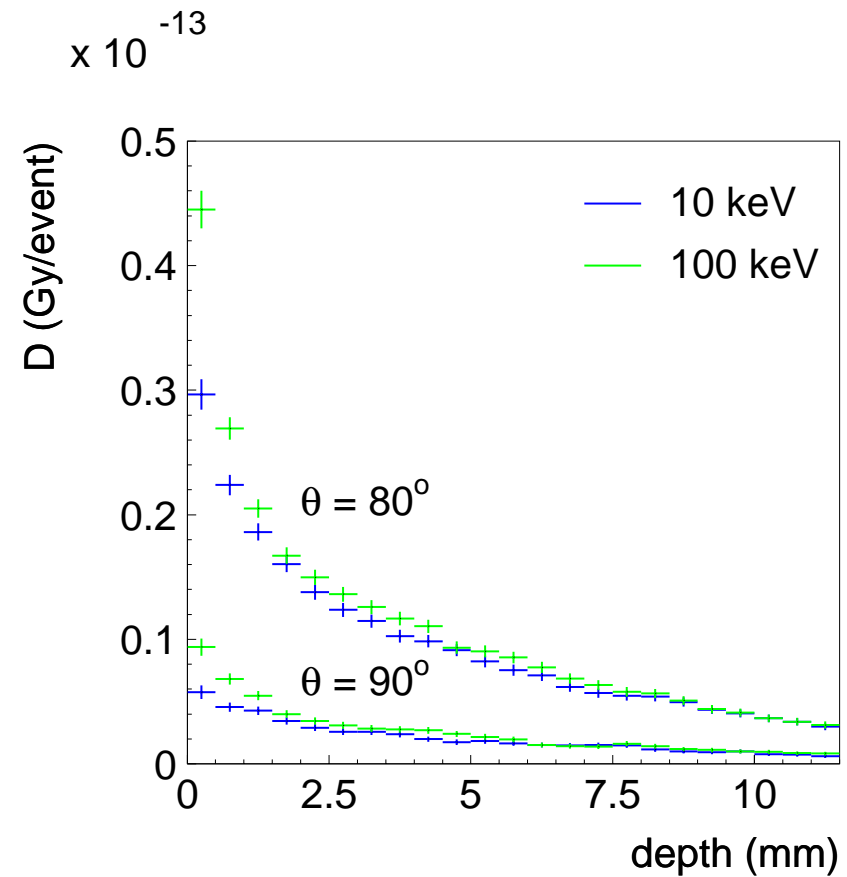
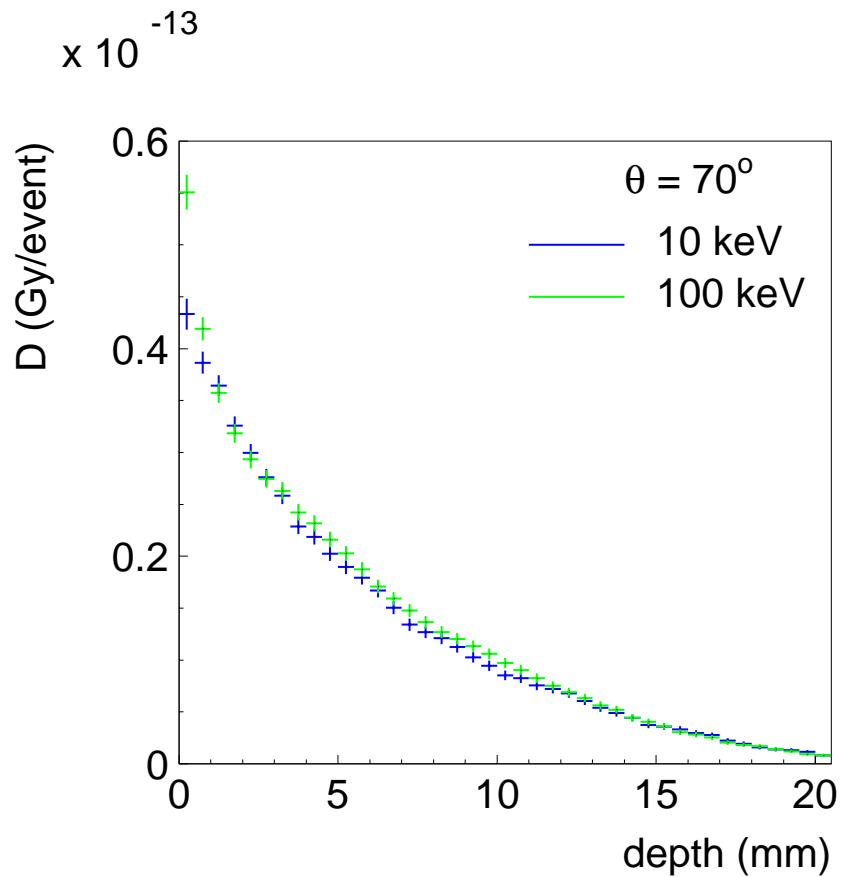

Ratio $D^{\text{stat}}/D^{\text{rot}}$ at SSD = 250 cm

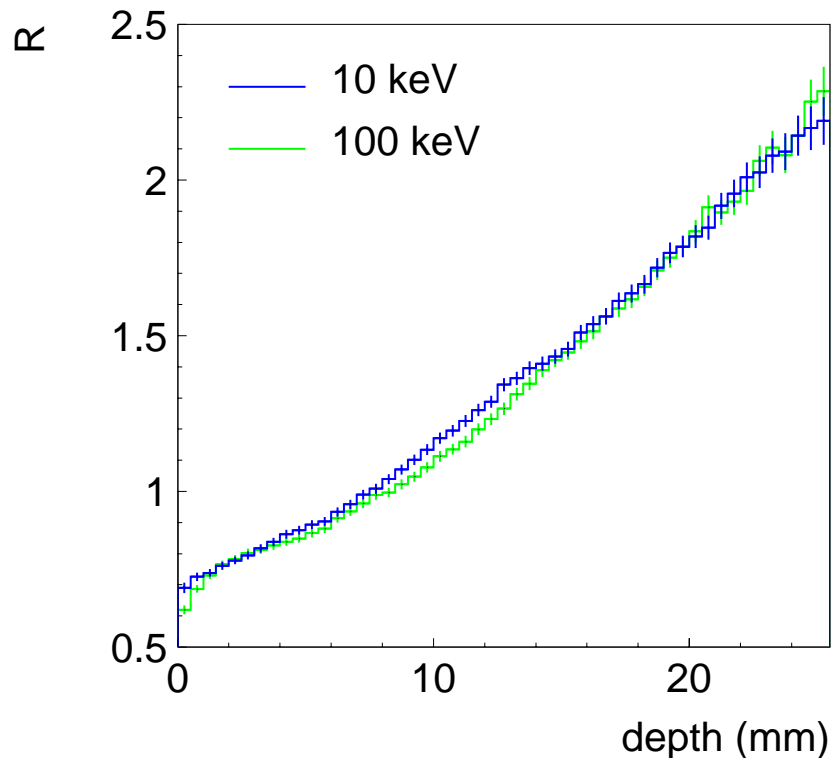

Absorbed dose in one rotation at
the prescription depth (5 mm):

$$R = 0.88$$

fraction dose = 2 Gy

- without degrader:

$$D^{\text{rot}} = 0.42 \text{ Gy}, N^{\text{rot}} = 5$$

- with degrader:

$$D^{\text{rot}} = 0.23 \text{ Gy}, N^{\text{rot}} = 9$$

Threshold dependence at SSD = 100 cm

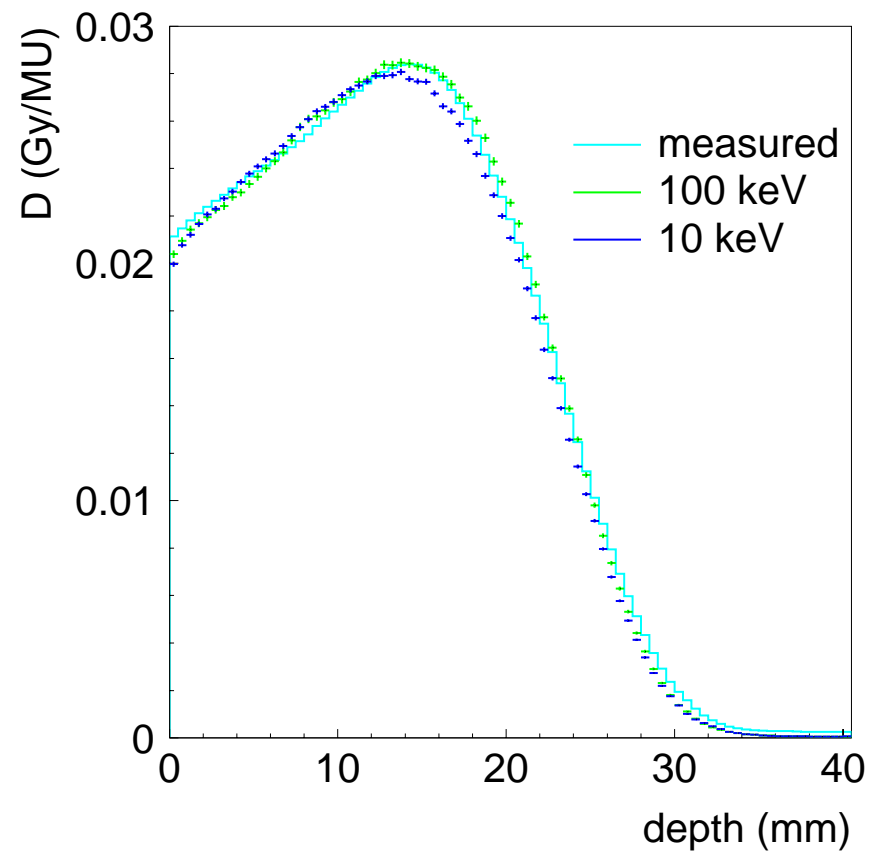

Threshold dependence at SSD = 100 cm

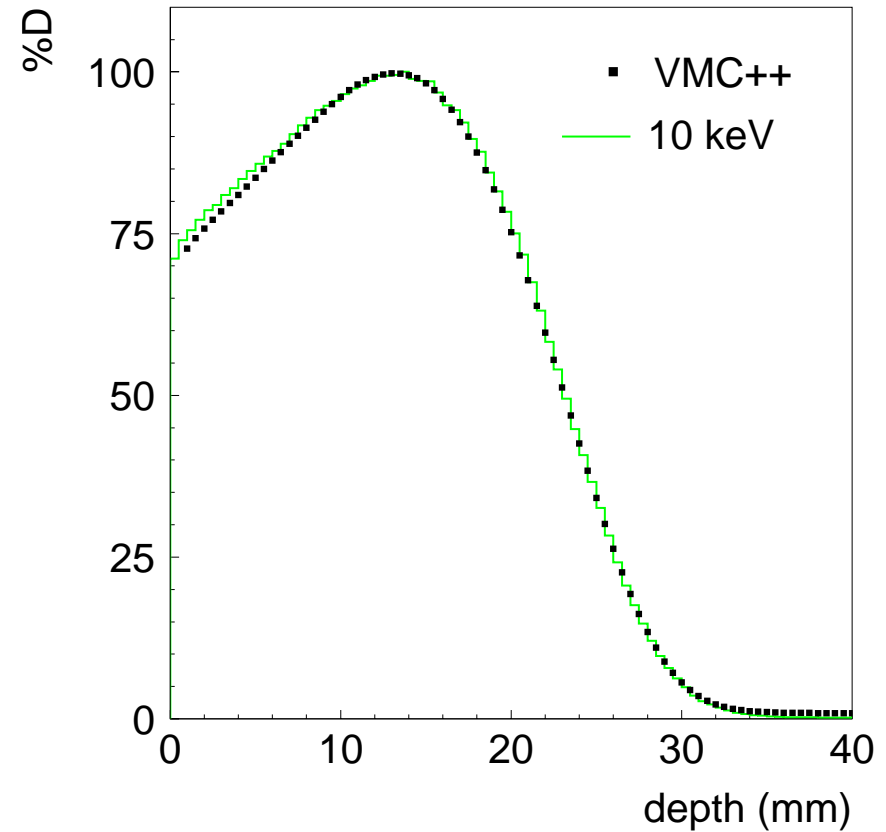
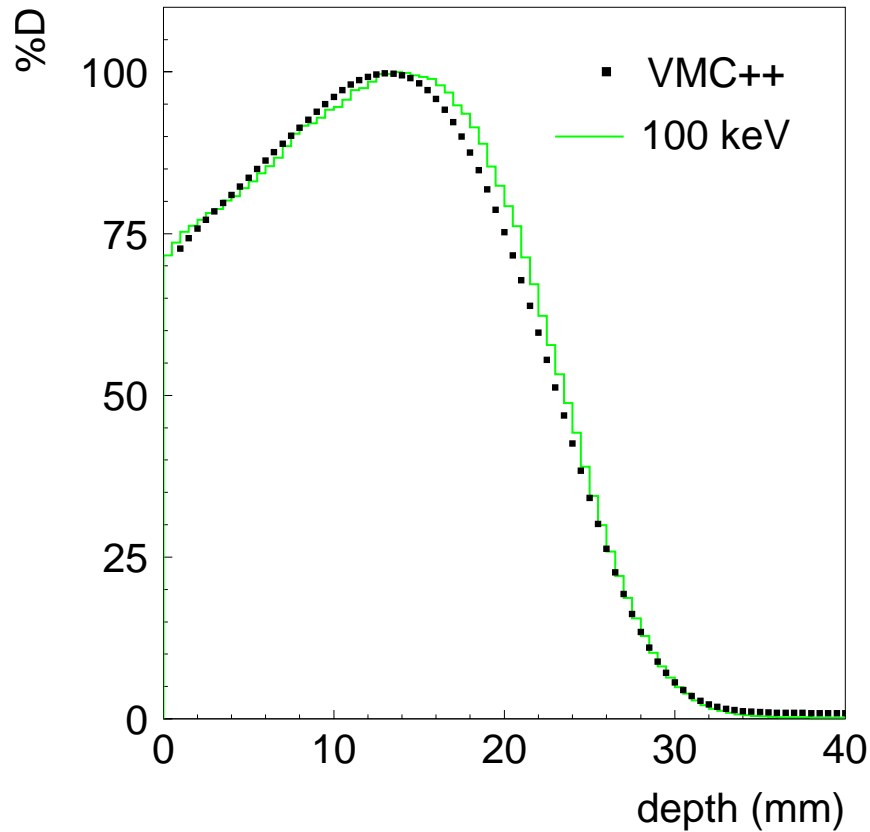

Conclusions

- the low-energy em physics model gives a good agreement both with measurements and with VMC++
- the simulation has a dependence on the electron production threshold (when no limit on step length is set)
- R can be calculated for 100 keV electron threshold
- step length distribution?
- dependence on beam angle?
- set maximum step length?
- ...