

What is the hadron-therapy?

Use of ions for the radiotherapeutic treatment of tumours

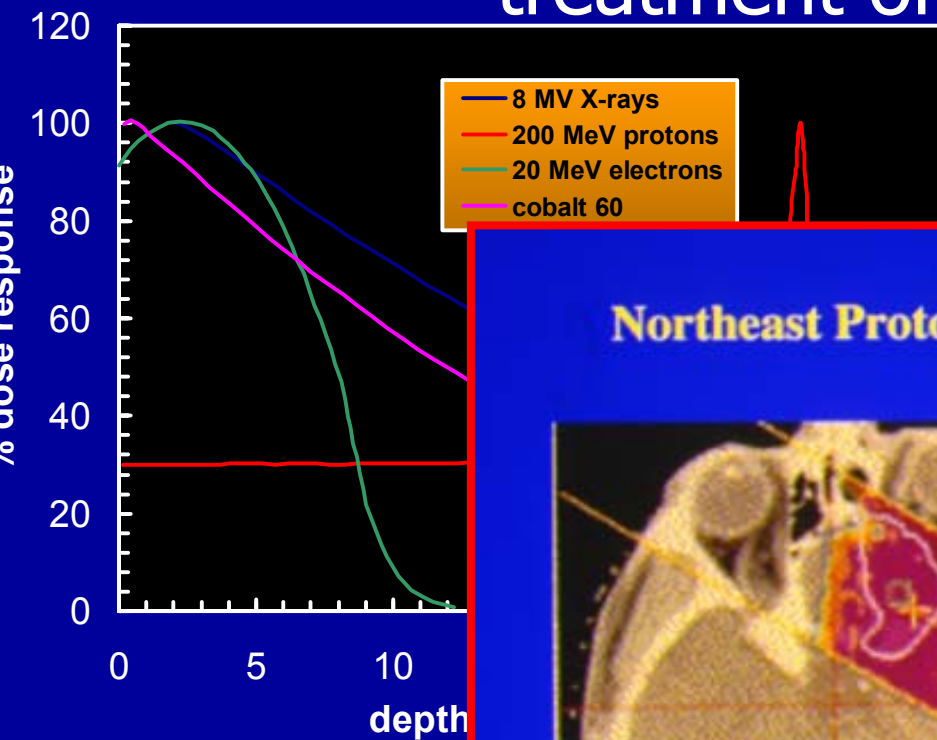

Northeast Proton Therapy Center: MGH Boston USA

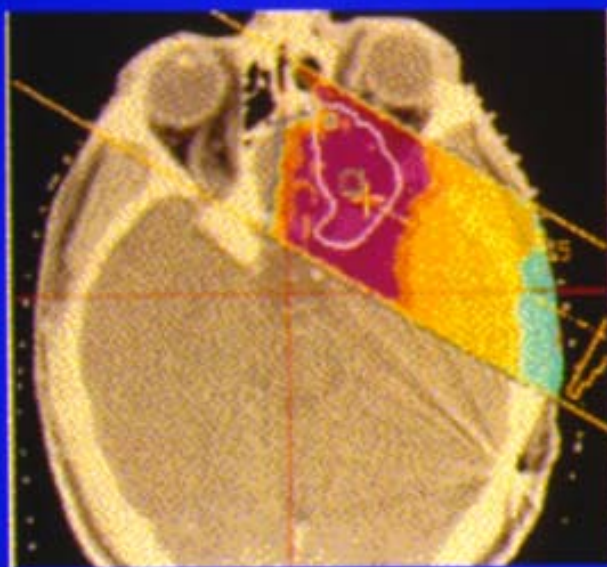

Protons

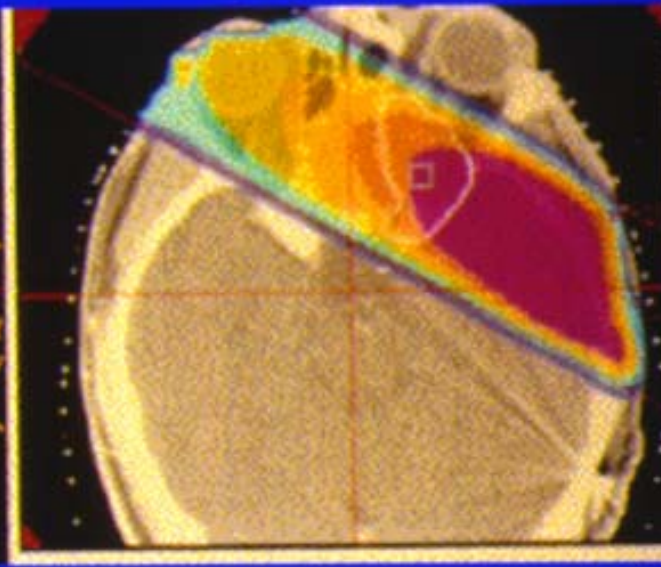

High energy X-rays

Single field

So we can answer to the question: Why clinical proton beams?

- penetration depth is *well-defined* and *adjustable*
- most energy at *end-of-range*
- protons travel in *straight lines*
- dose to *normal tissue* minimised
- **no dose** beyond target

PROTONS PERMIT TO DELIVER AN HIGH DOSE TO
THE TUMOUR SPARING THE SOURROUNDING TISSUES

In Catania we developed a facility **CATANA** for the treatment of ocular tumours with proton beams of 62 AMeV

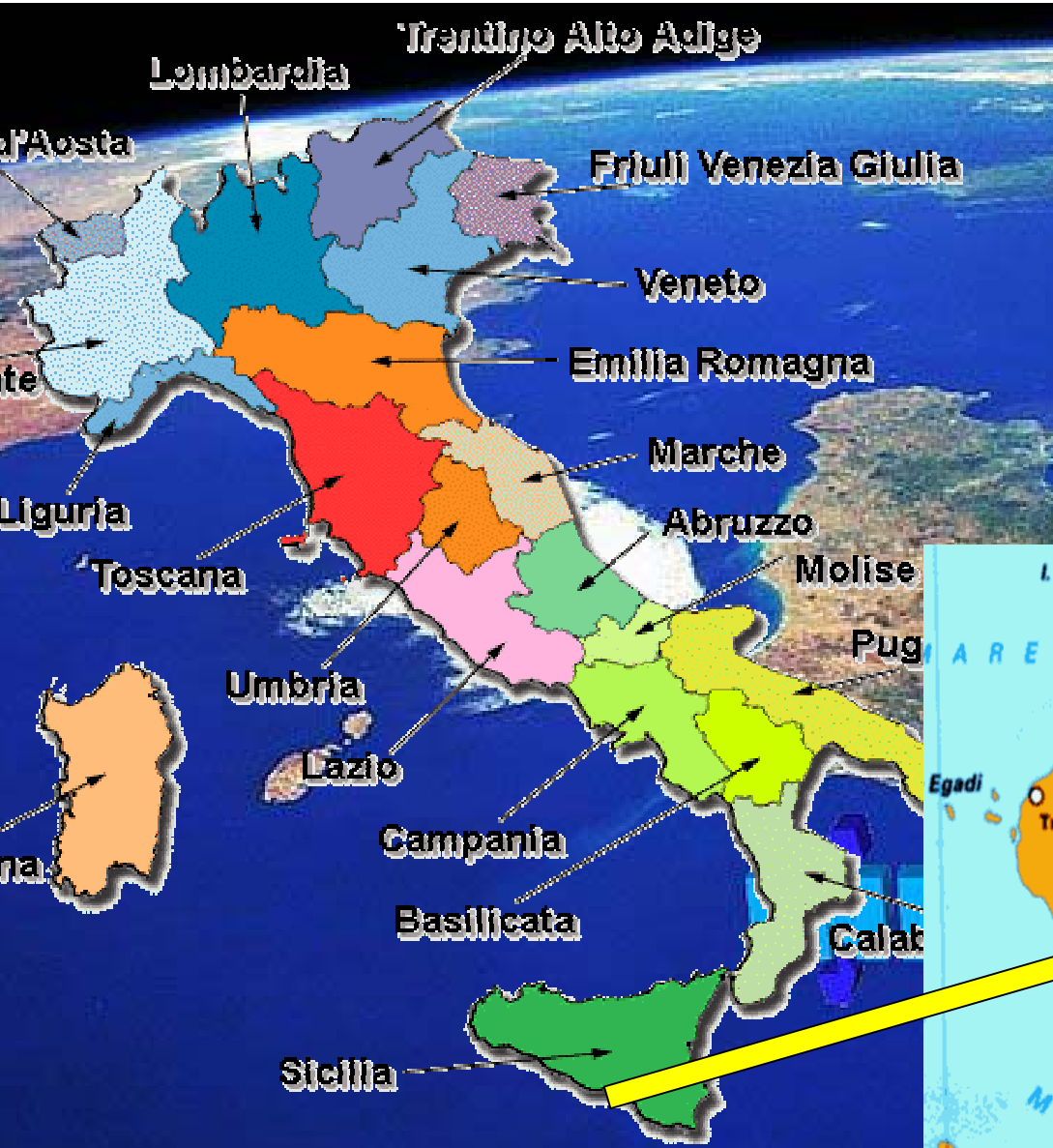



LNS
Superconducting Cyclotron is the unique machine in Italy and South Europe used for protontherapy

Treatment of the choroidal and iris melanoma
In Italy about 300 new cases for year

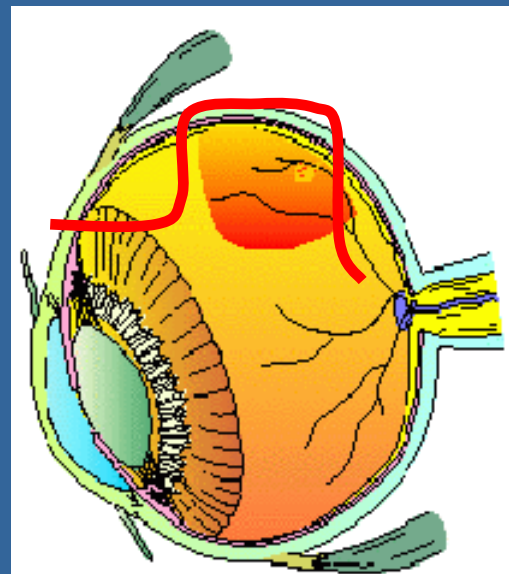

Laboratori Nazionali del Sud –INFN Catania, Italy

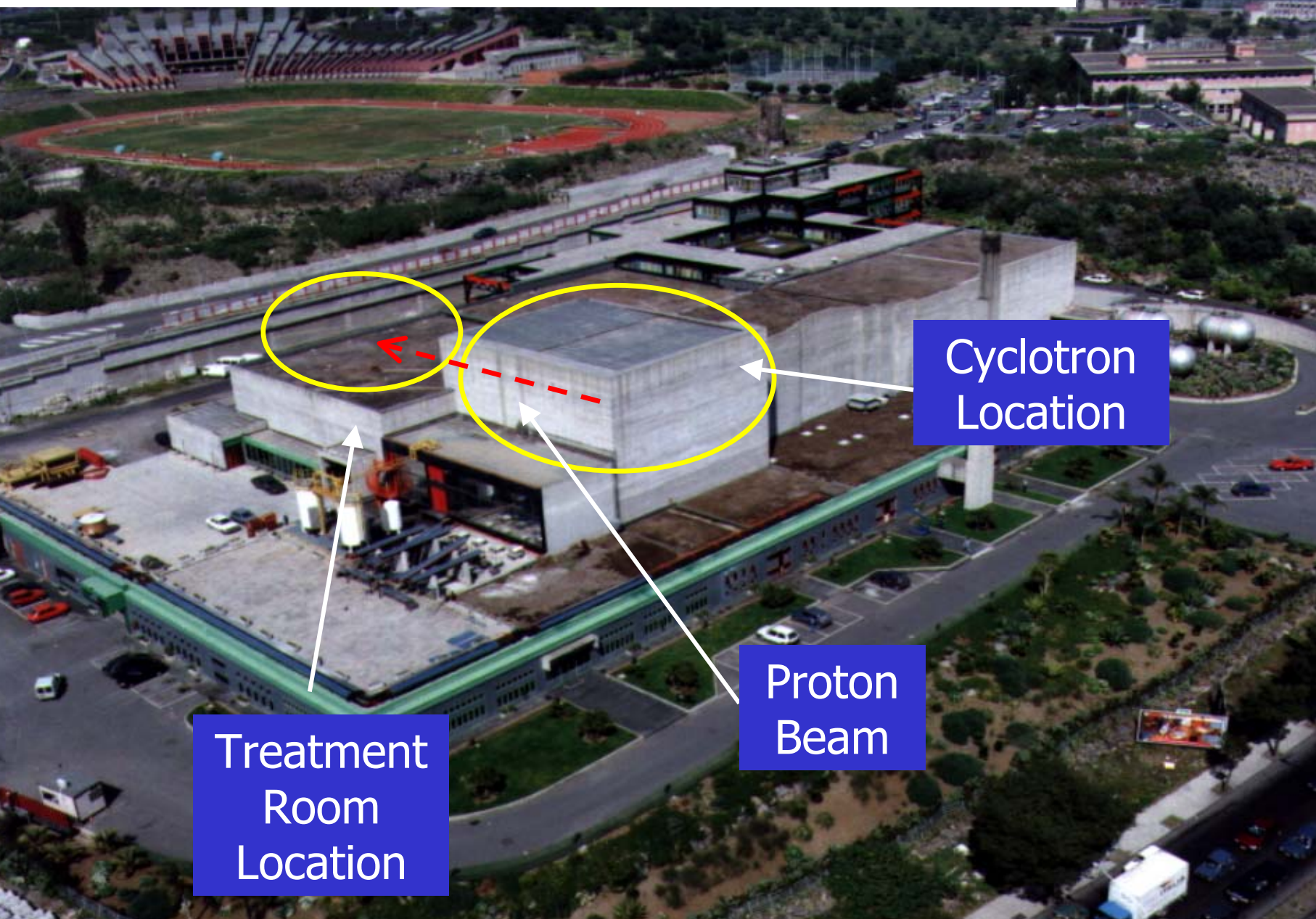

Cyclotron
Location

Proton
Beam

Treatment
Room
Location

PRESENT TREATMENT ROOM

- 0° respect the switching magnet
- 80 meter after extraction
- 3 m proton beam line

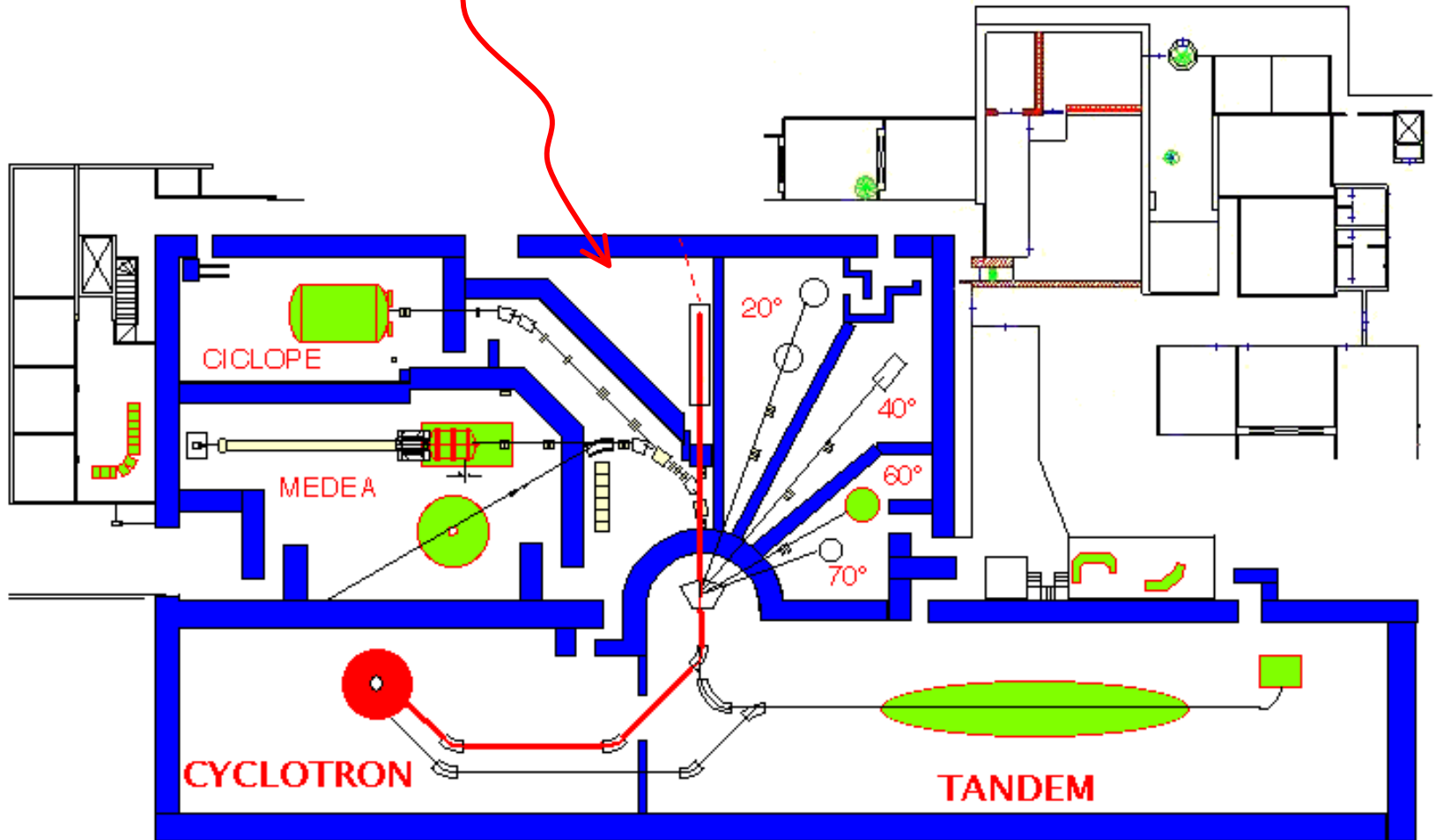

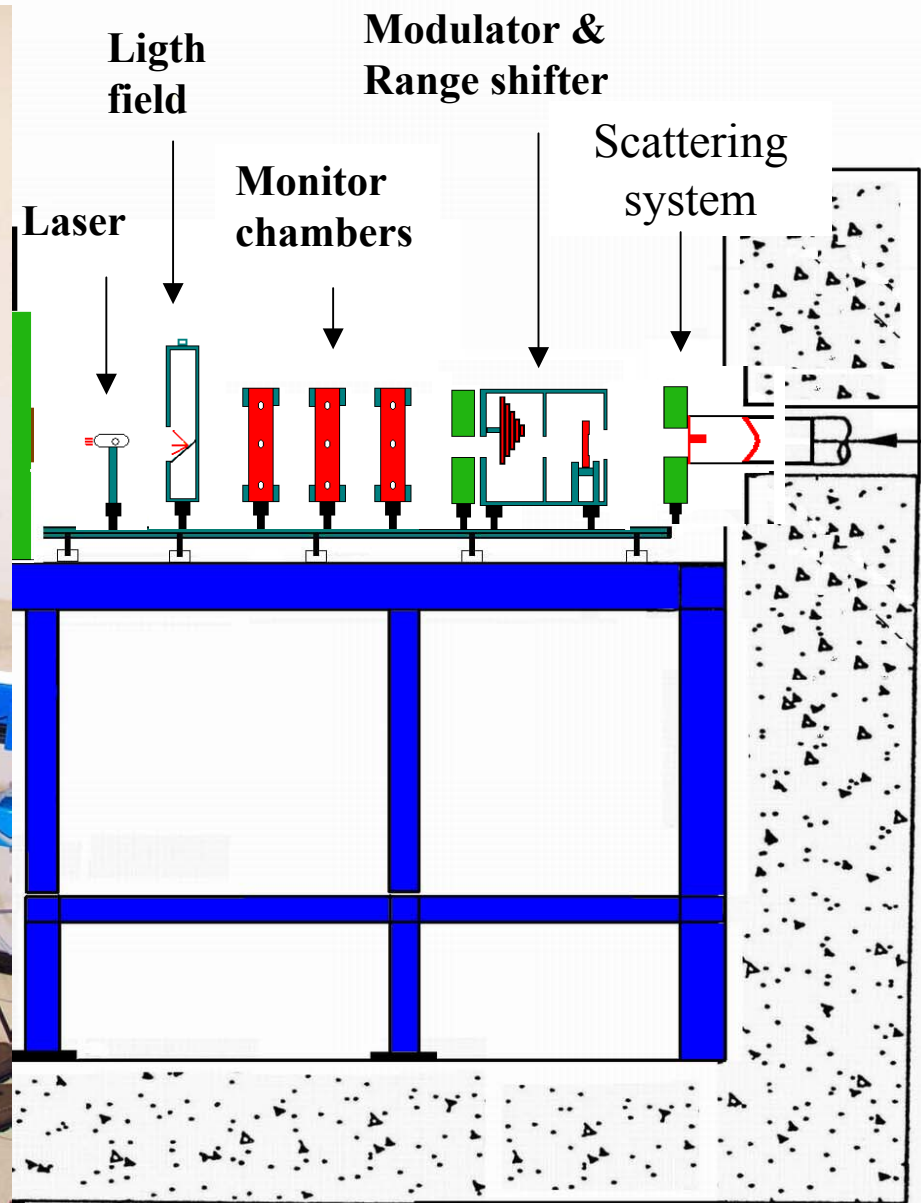

Surgical Phase (Tantalum clips insertions)

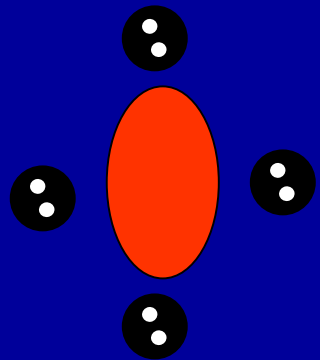

CLIPS: characterize position and size of tumor volume

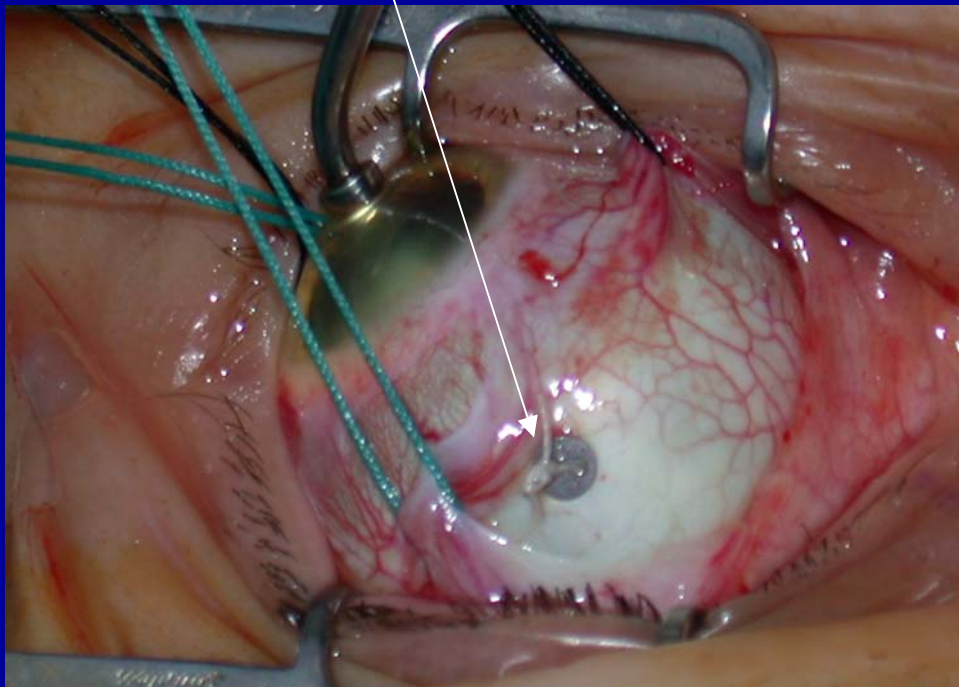

EYEPLAN

In origin developed by Michael Goiten e Tom Miller (Massachusetts General Hospital) e ora maintained by Martin Sheen (Clatterbridge Center for Oncology) e Charle Perrett (PSI)

Isodoses curves for different planes

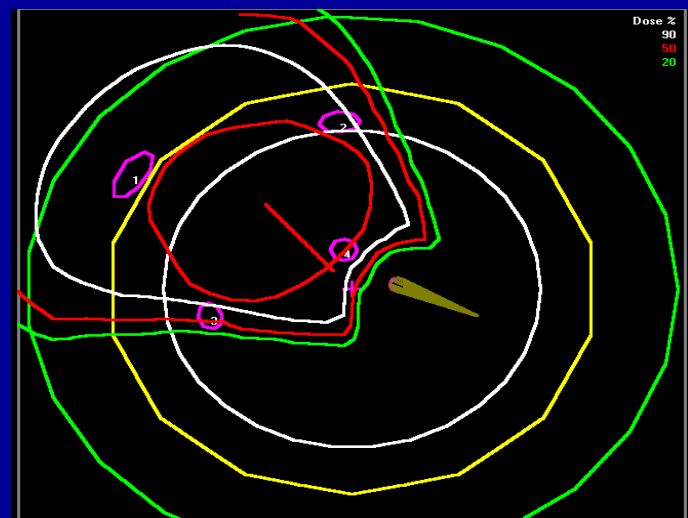
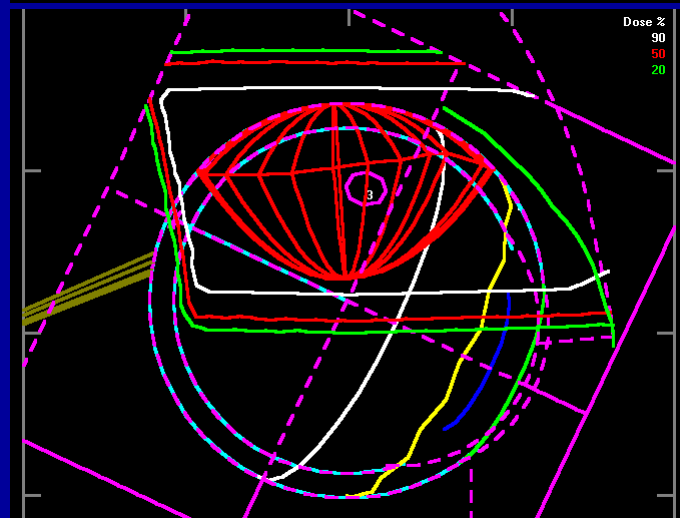
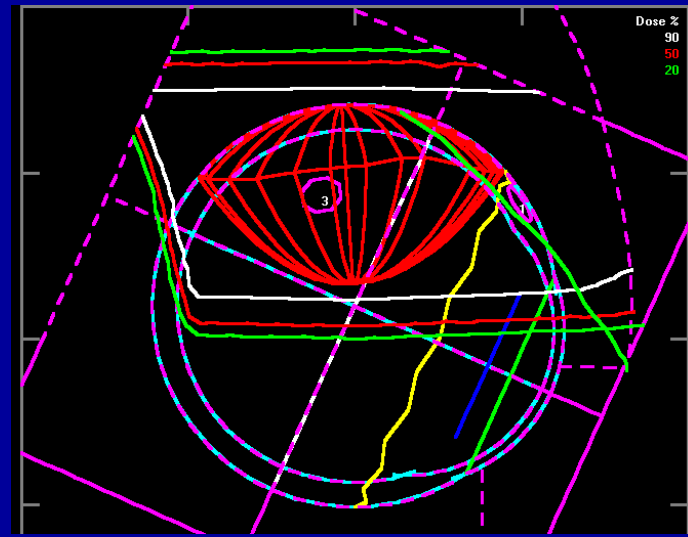
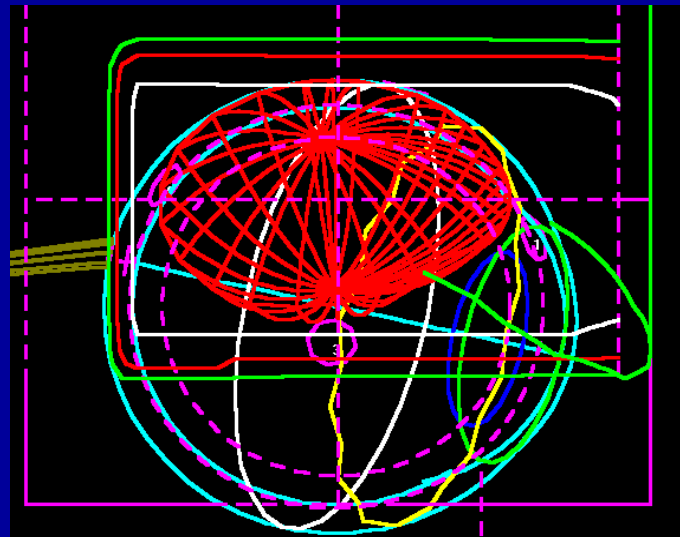

Patients look at the fixation light during the treatment

ROTON BEAM

15 03 2002 10:58

Patient Distribution by Origin Region

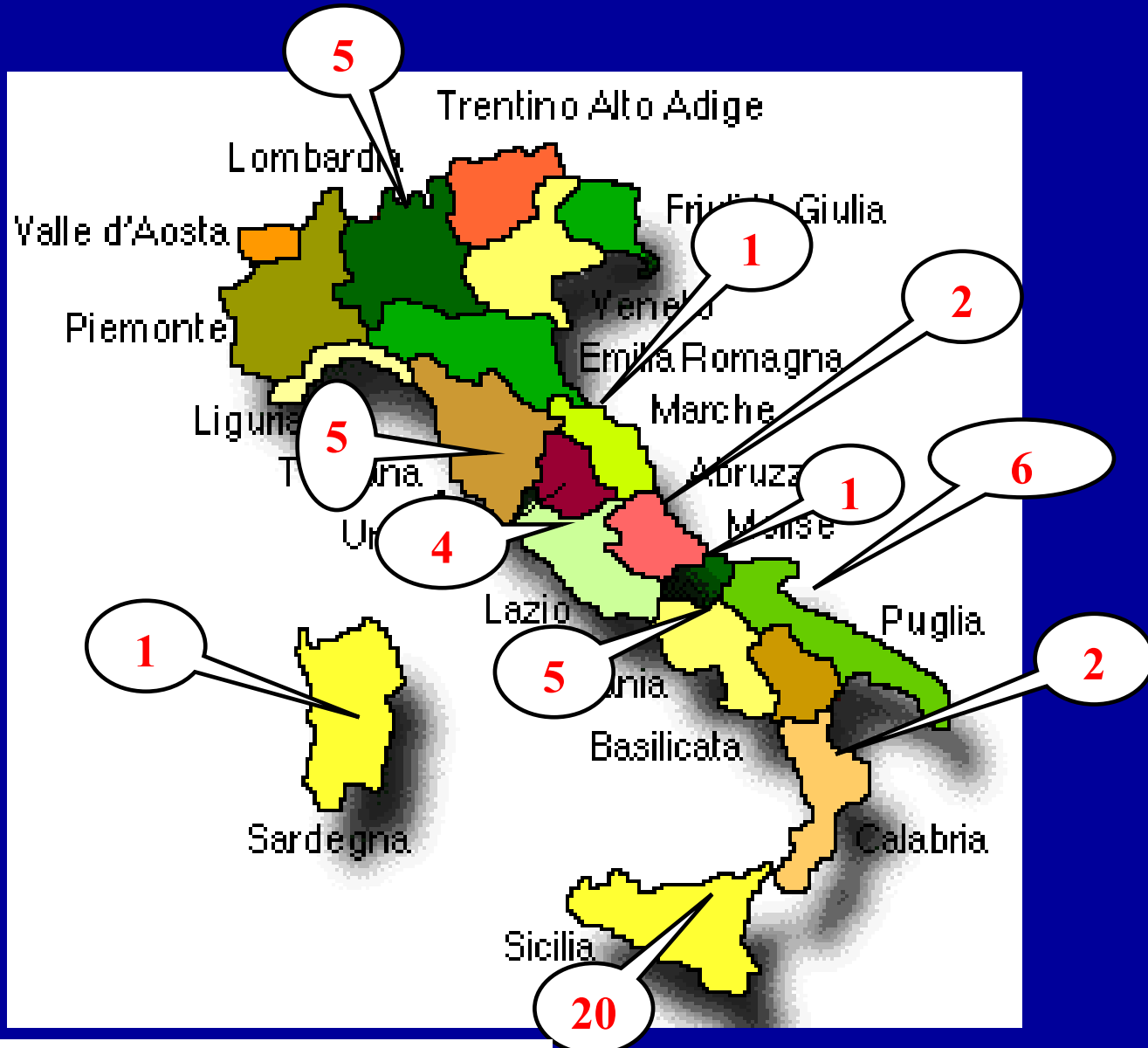

N.B Total number of patients : 66

Total number of patients : 66

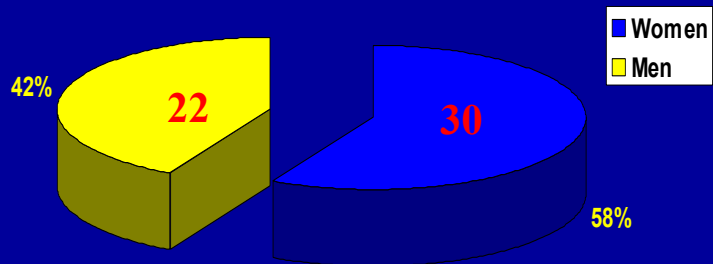
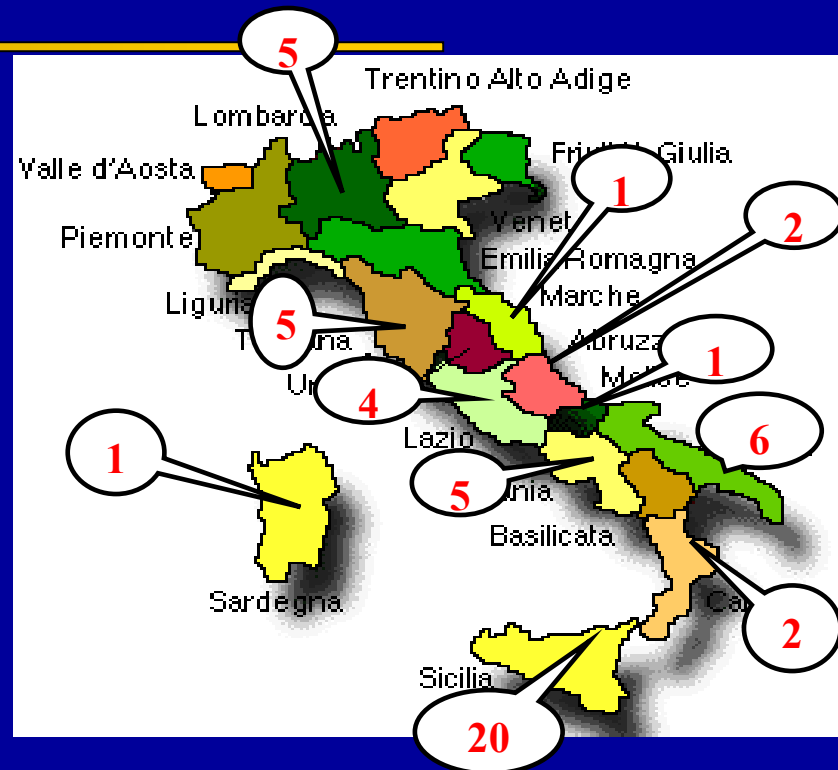

Mean age: 57.6 yrs

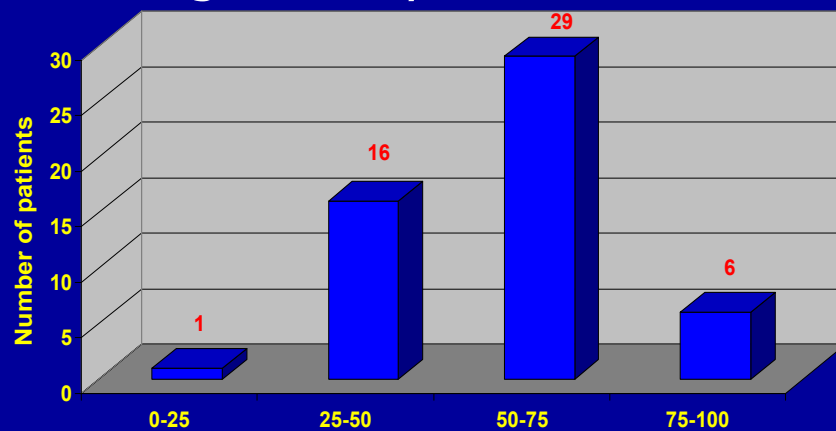

Why to start a Simulation Work ?

Therapy with hadrons still represents a pioneering technique

Today the development of a hadron-therapy facility requires a long experimental work due to the lack of
SIMULATION TOOLS

Our work is inserted in the more general **medical-physics GEANT4 activity** and represents just a different application of a more general approach in the medical-physics field

Why to start a Simulation Work ?

This work concerns mainly:

Design and optimization of the transport beam line elements:

Test of the elements

Test of the detectors

Reconstruction of the dose distributions:

To measure dose distribution also in difficult experimental region

To verify the radiotherapy treatment planning systems

Why to start a Simulation Work ?

So we start our simulation work using GEANT4:

- **To simulate our complete beam line with all its elements and**
- **To reproduce all the dose distributions**

It's impossible to conceive a modern detector w/o simulation

Rossi and Greisen 1941, Rev. Mod. Phys. 13:240

Complete simulation of CATANA hadron-therapy beam line with two dosimeters

- Depth Dose Distribution in Water (Bragg curve):
Markus type ionization chamber;
- Lateral Dose Distribution:
Radiochromic film;

Material and Methods

DETECTORS USED FOR DOSE DISTRIBUTION MEASUREMENTS

DEPTH DOSE DISTRIBUTION

LATERAL DOSE DISTRIBUTION

- Markus Ionization chamber

- GAF Chromic Film

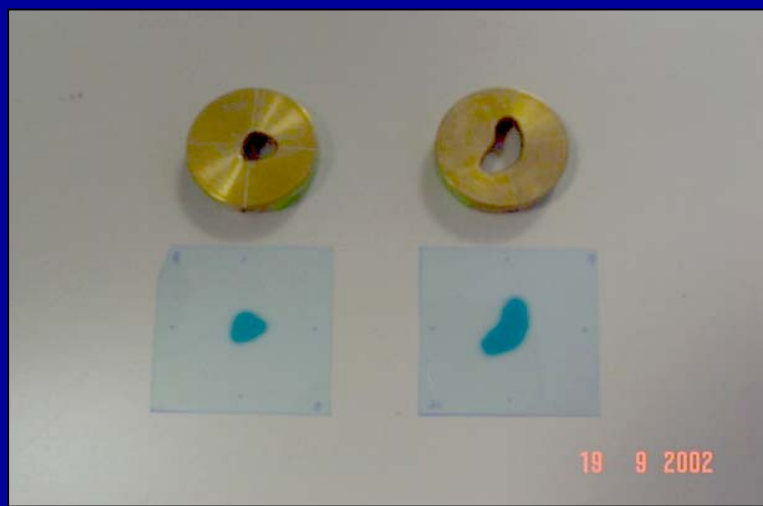
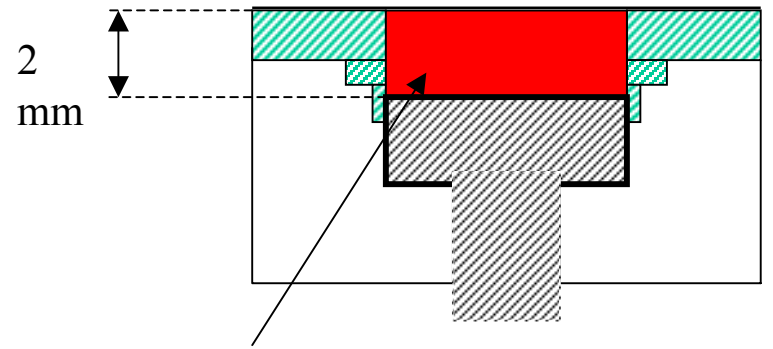

Markus Chamber layout

Irradiated GAF Chromic

Resolution 100 μm for DDP and 200 μm for LDP

TIPICI RIVELATORI PER LA RICOSTRUZIONE DELLE CURVE DI DOSE

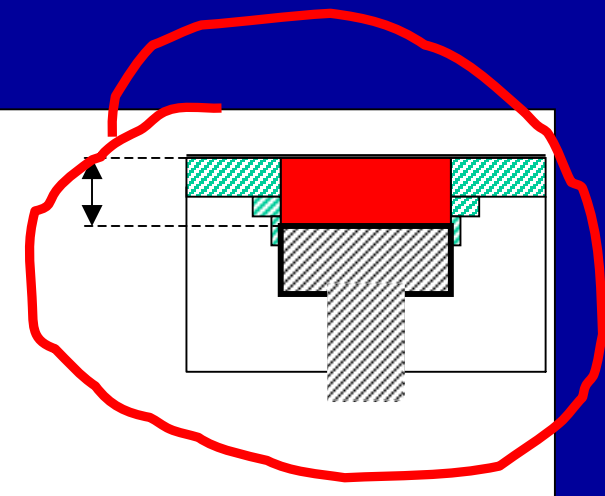

Camera a ionizzazione



TLD

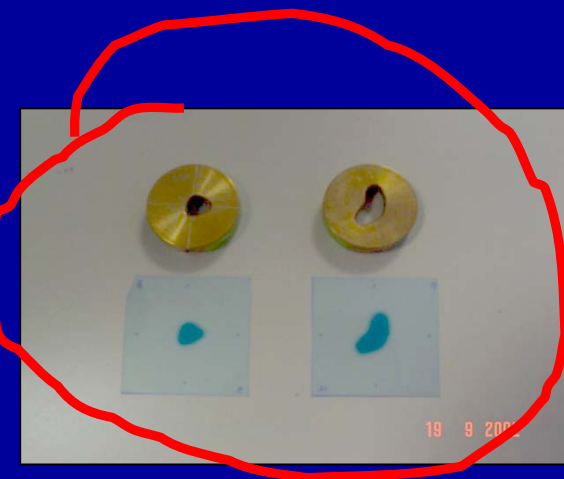

Gaf



Diodi



Diamanti

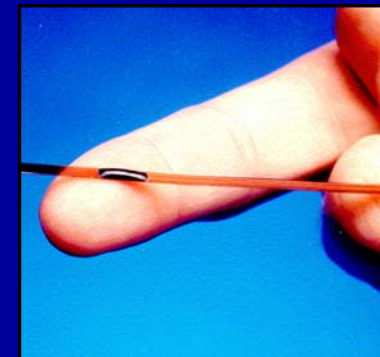

MOSFET

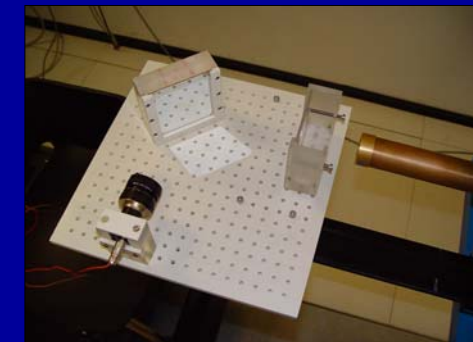

Scintillatore + CCD

Experimental 'PURE' Bragg curve

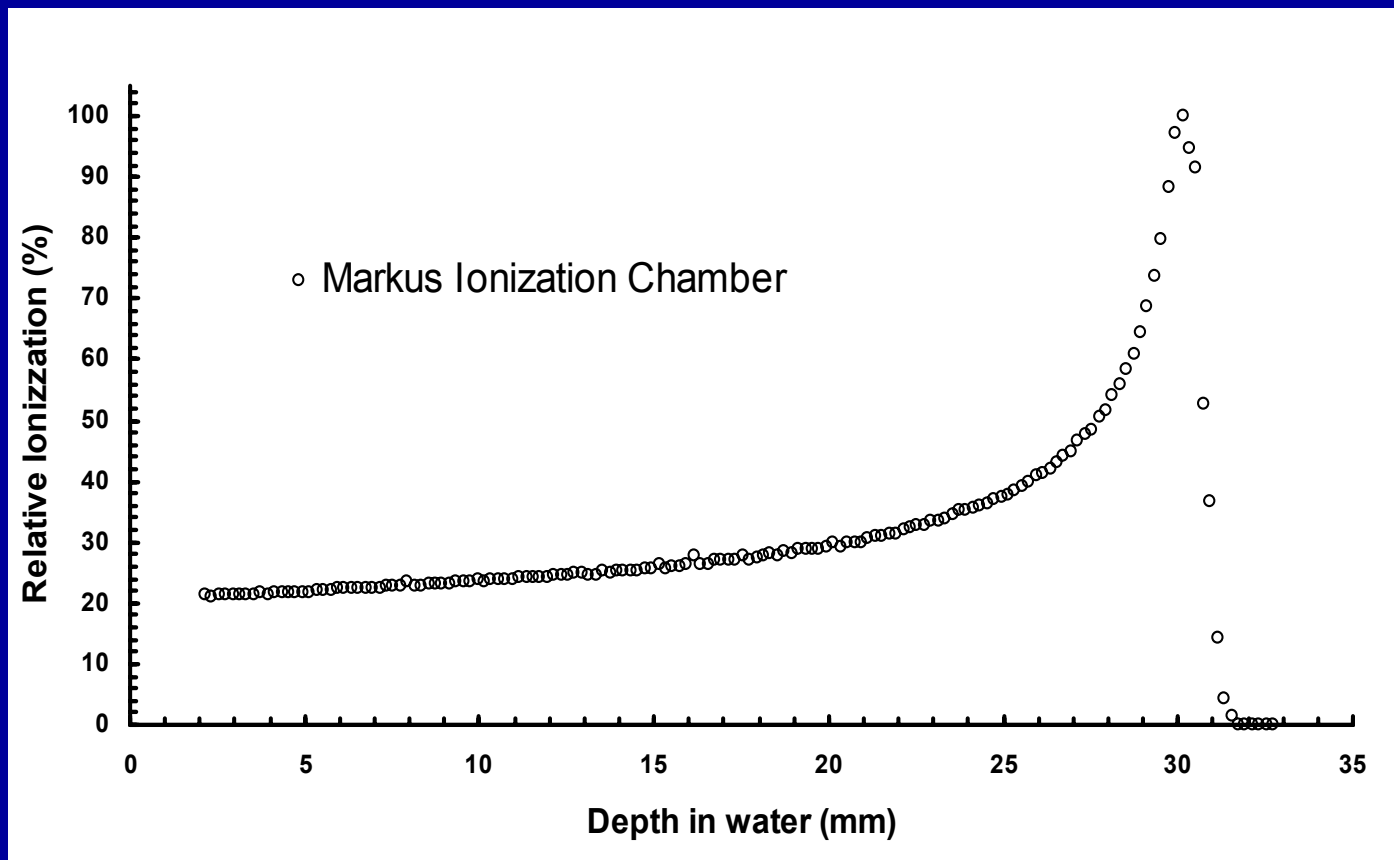

DETECTOR	PEAK DEPTH	PEAK – PLATEAU RATIO	F.W.H.M.	Distal - dose falloff $d_{80\%-20\%}$	Practical Range ($d_{10\%}$, ICRU 59)
MARKUS	30.14	4.68	3.19	0.50	31.15

Experimental 'modulated' Bragg curve

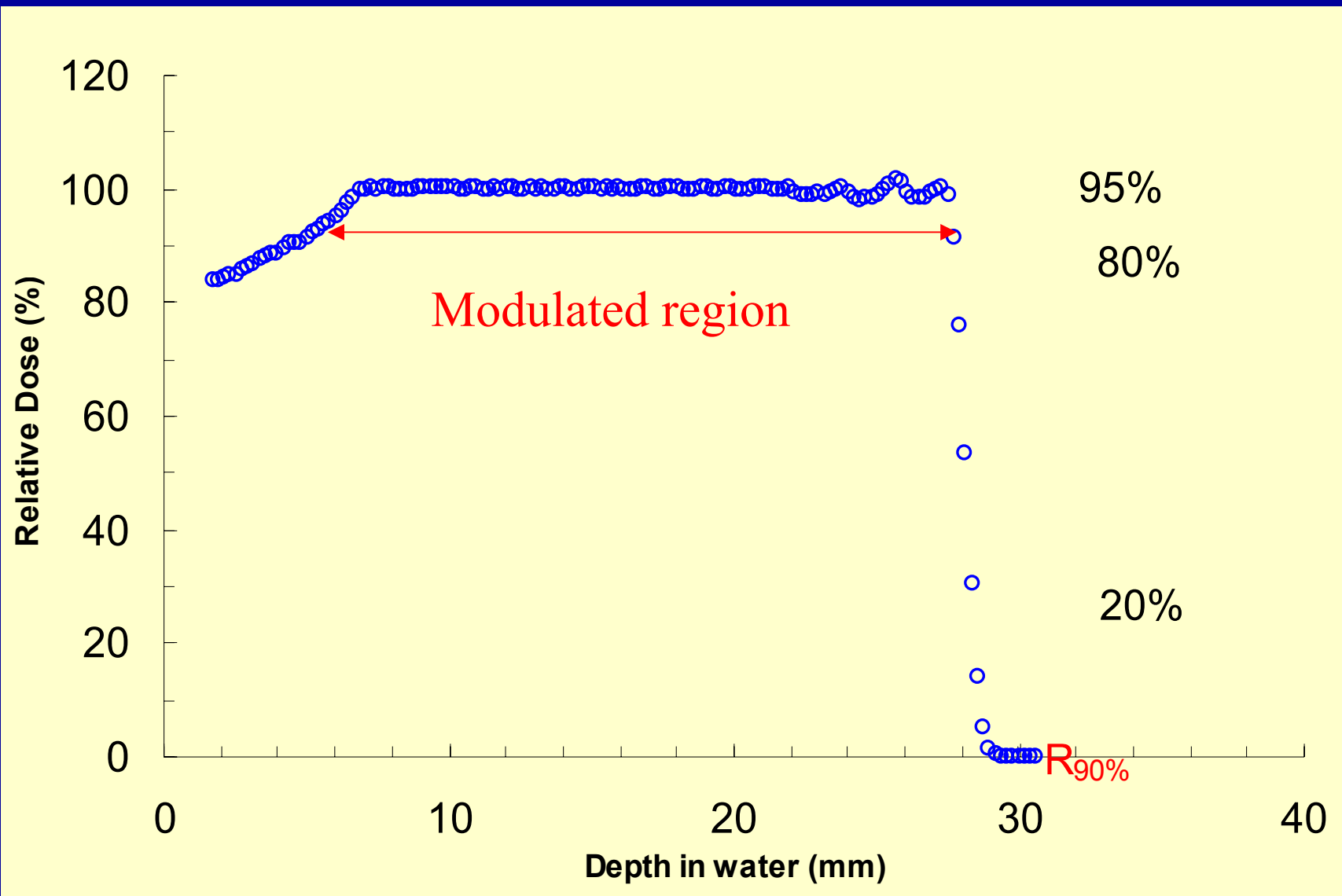

Experimental Lateral Dose Distribution

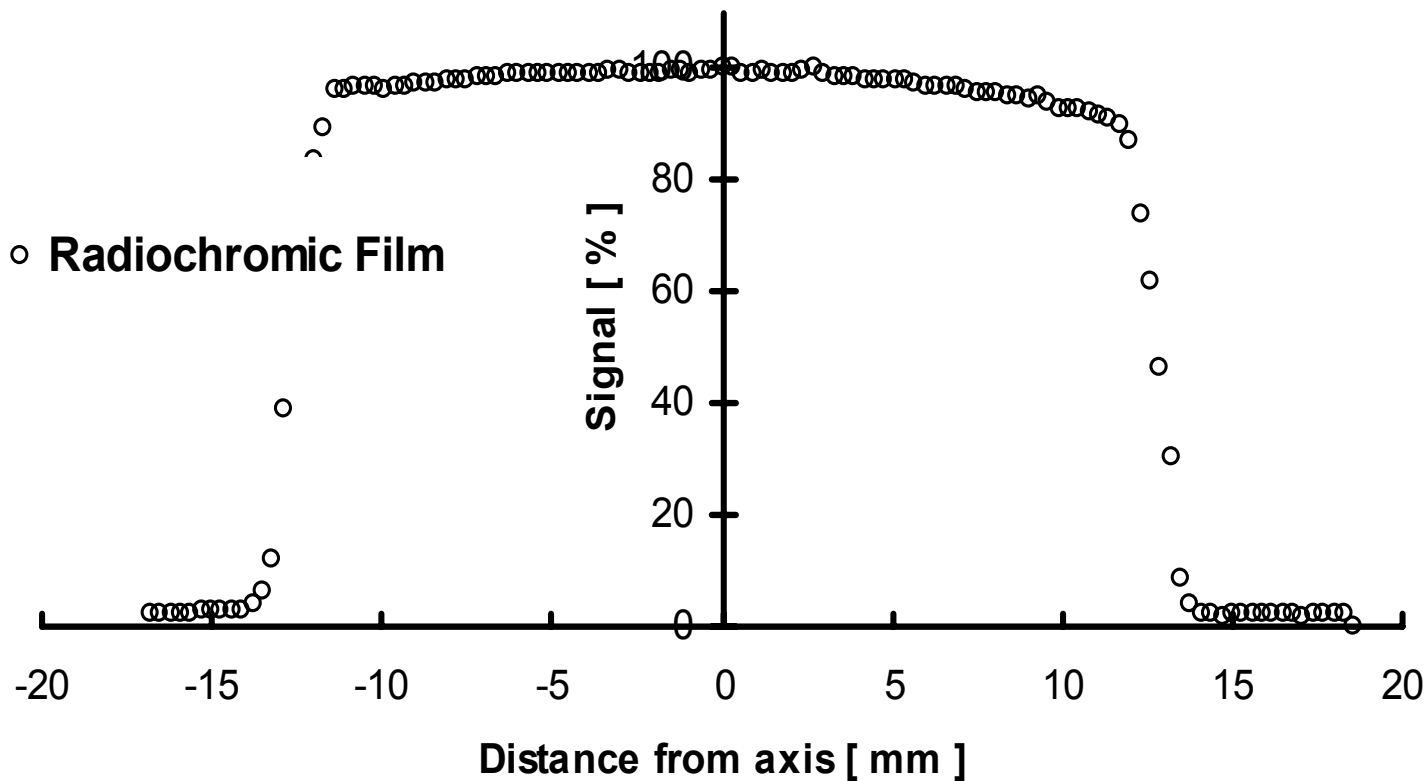

	$R_{90\%-50\%}$	Ps [mm]	Pd [mm]	Simmetry [%]	Homogeneity at 95% level [mm]
LNS	0.92	0.8	1	2.4	21
CCO	0.93	0.75	0.75	2.6	23

Bragg Curve Reconstruction

Detector is simulated with
20 K air cylindrical slices, 200 μm thick
to reproduce experimental Markus chamber response

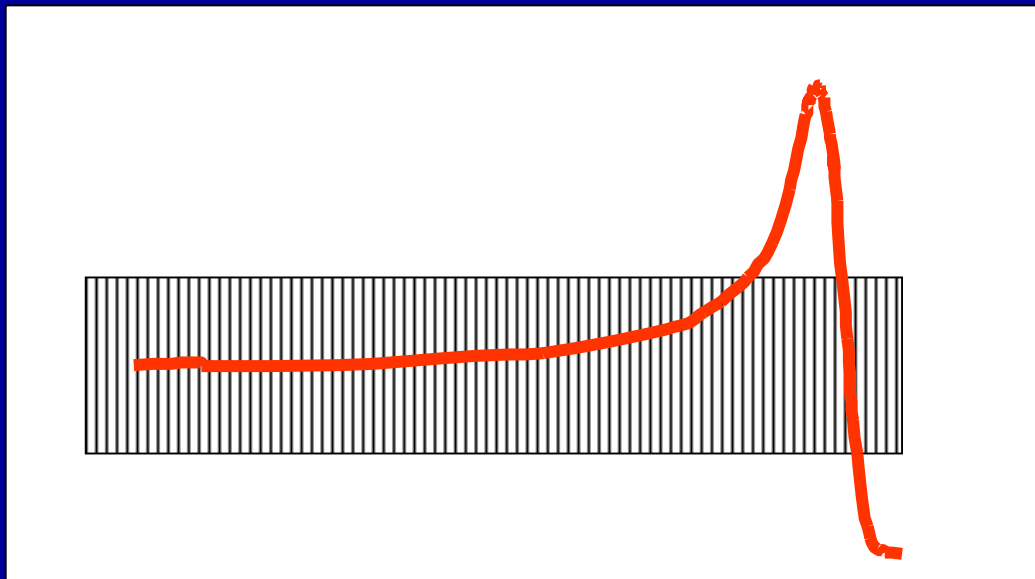

Energy deposited in
each slice is collected

We calculated range values for the detector
simulation validation from Bragg curve

Bragg Curve Reconstruction

Water box with
ionisation chamber

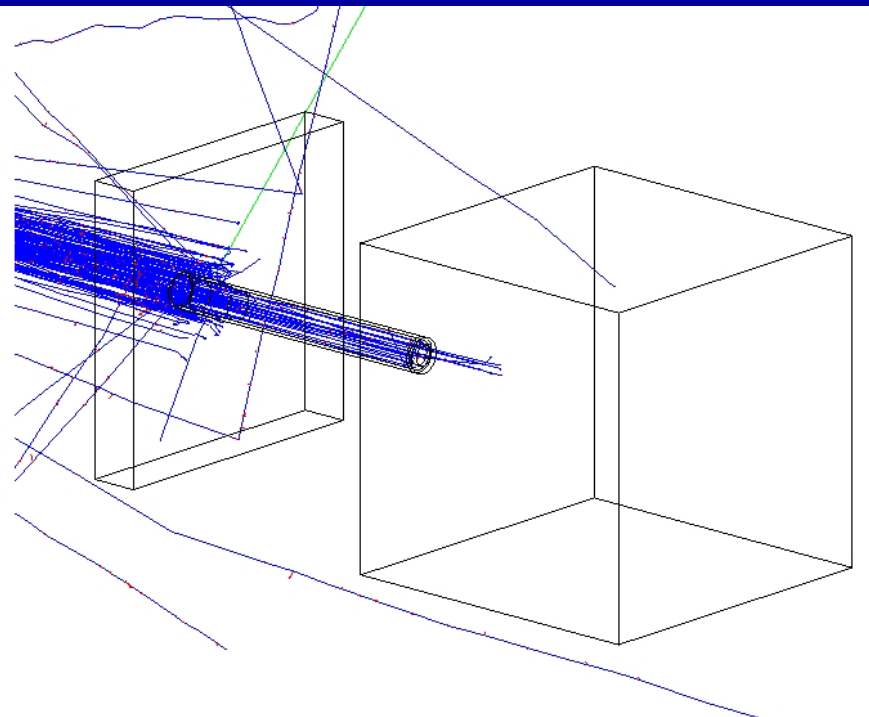
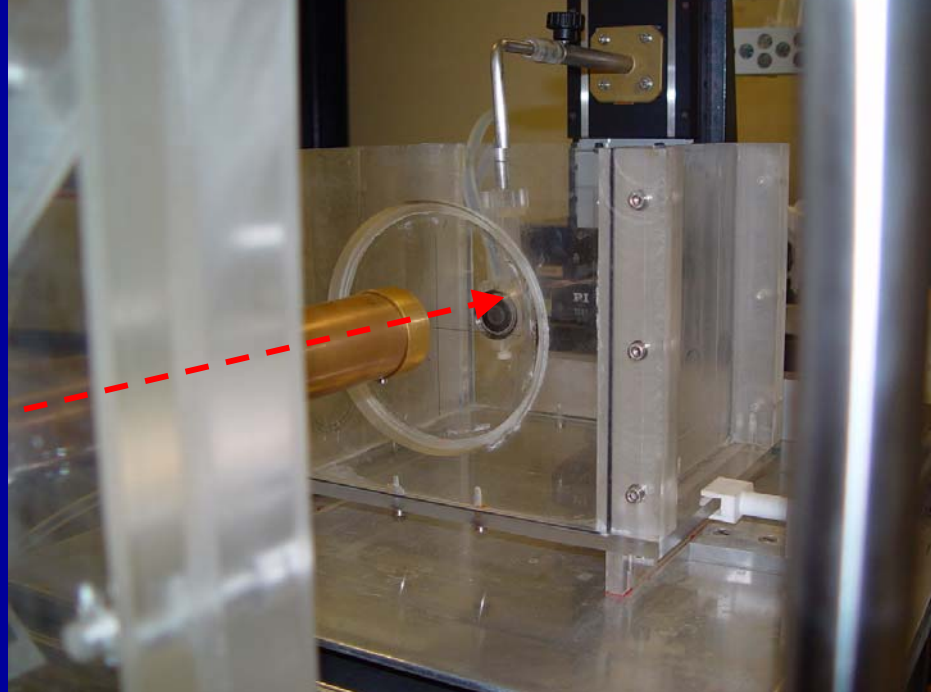

Water box + detector
for Bragg curve as
simulated

Validation of Simulated Detector (From a Software point view) Comparison with NIST ranges data

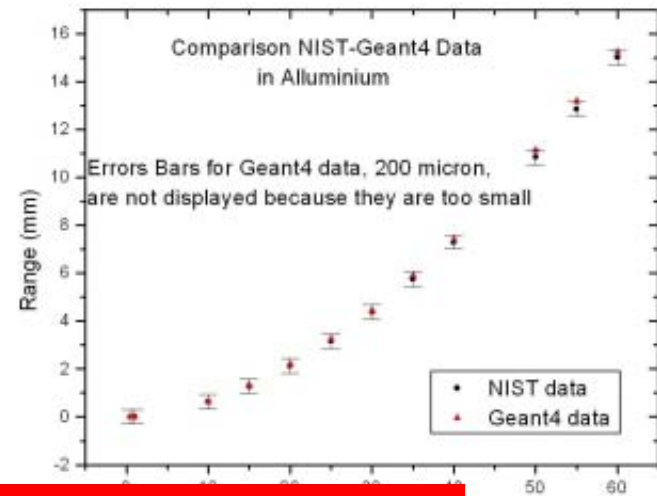
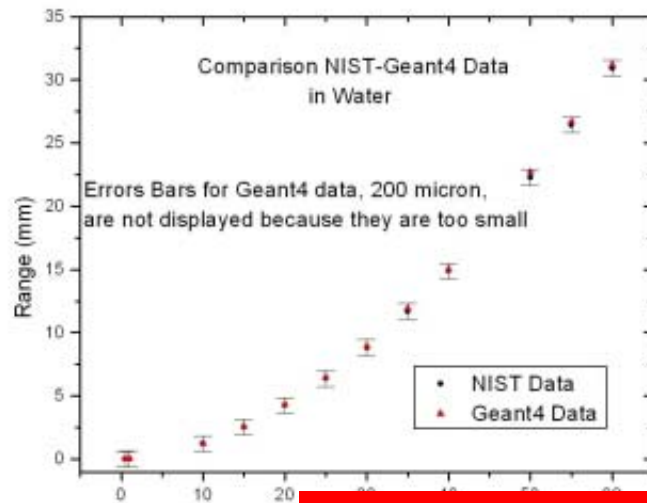

NIST DATABASE COMPARISON

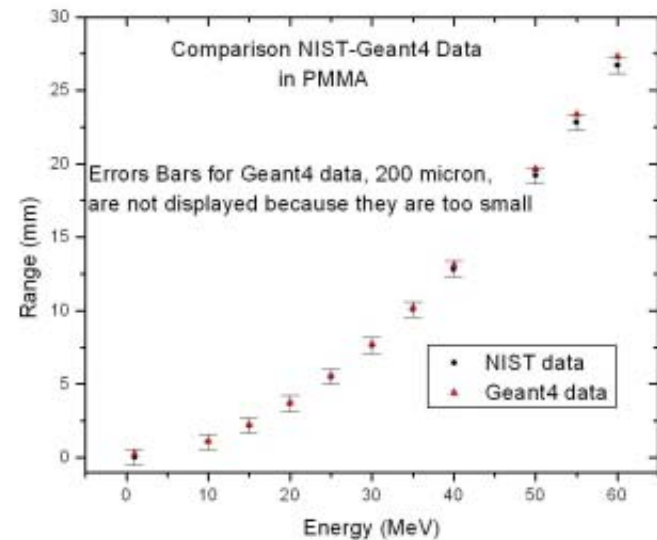
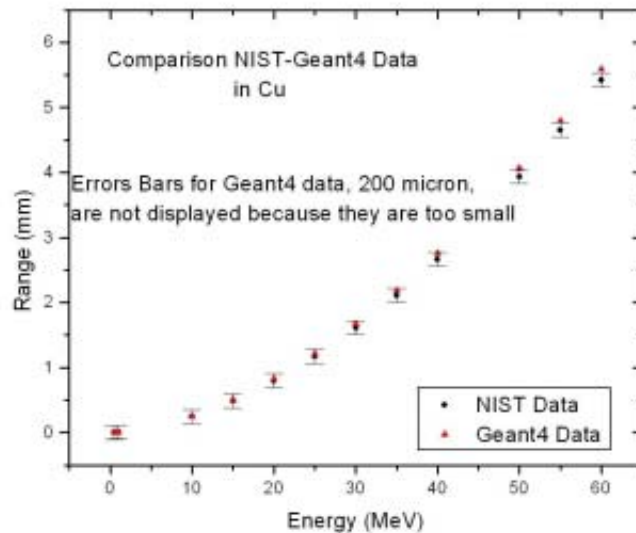

Beam Line Simulation: Scattering system

DOUBLE SCATTERER FOIL WITH CENTRAL STOPPER

15 μm + 25 μm + 7 mm thick copper beam stopper

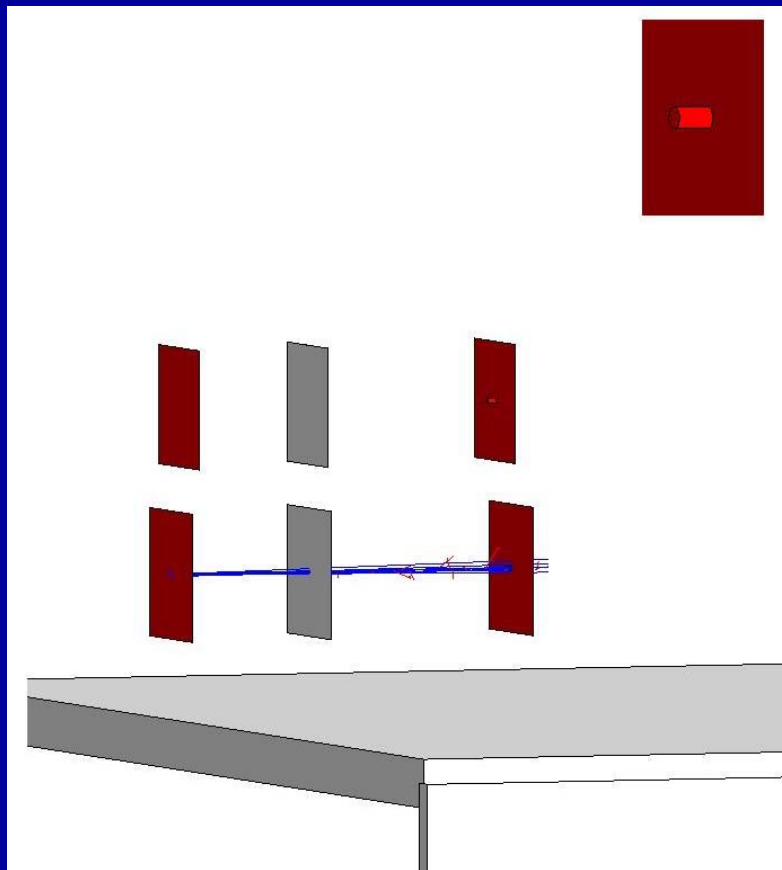
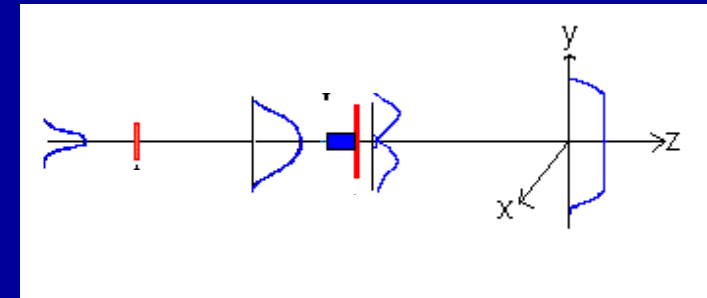

Permits to obtain an homogeneous lateral dose distribution at isocenter

Real hadron-therapy beam line

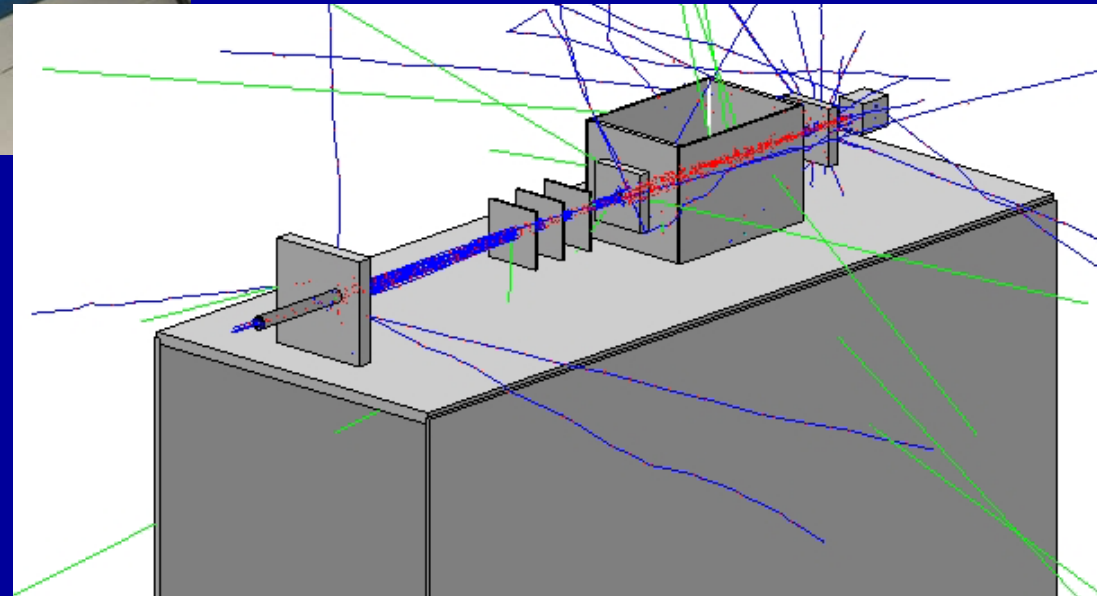

GEANT4 simulation

Each element of the line can be modified (in shape, material and position) and other kinds of dosimeters can be easily inserted

Physics models: comparison with experimental data

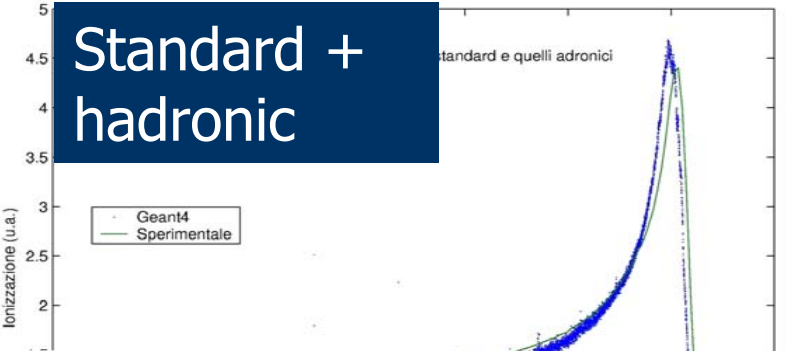
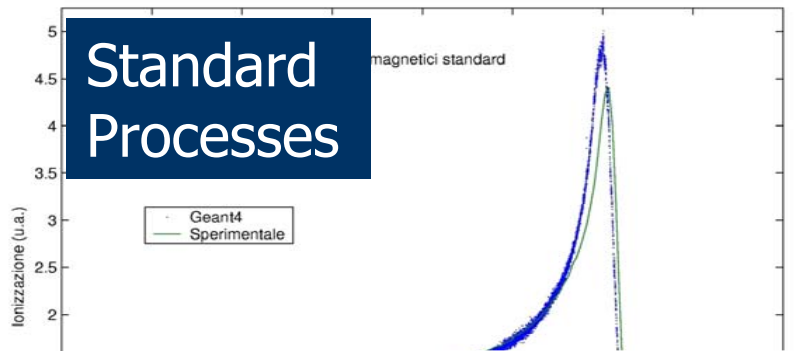

Kolmogorov test		
process	P-value	Test
Standard.	0.069	OK
Standard + Had.	0.40	OK
Low Energy	0.51	OK
Low En. + Had	0.699	OK

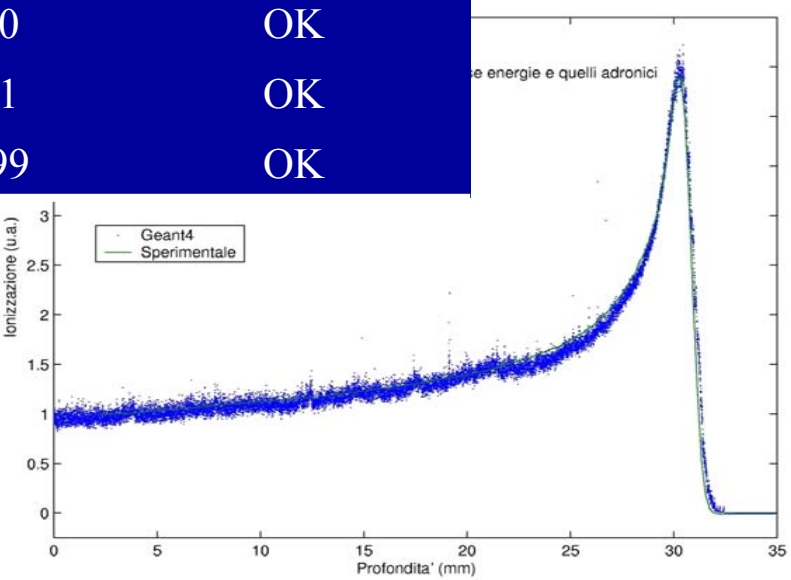
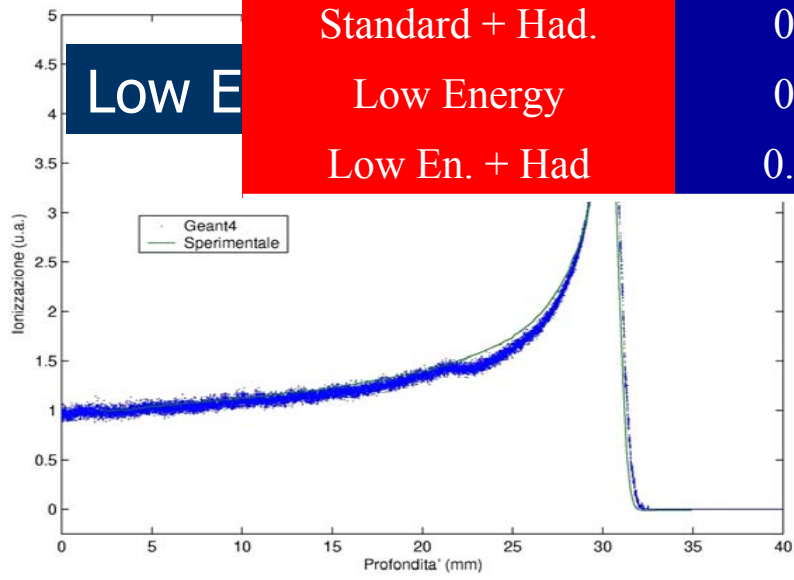

The best hadronic model we find in our investigation is the **precompound** (*Theory Driven Model* of GEANT4)

Validity range up to 6.8 MeV for protons and for any target material ($Z > 5$)

Hadronic processes

process

class

Inel. Nucl. Scatt..

G4HEProtonInelastic

Elastic Nucl. Scatt.

G4HadronElasticProcess

Fission

G4LFission

Experimental data comparison

Low energy libraries and hadronic physics

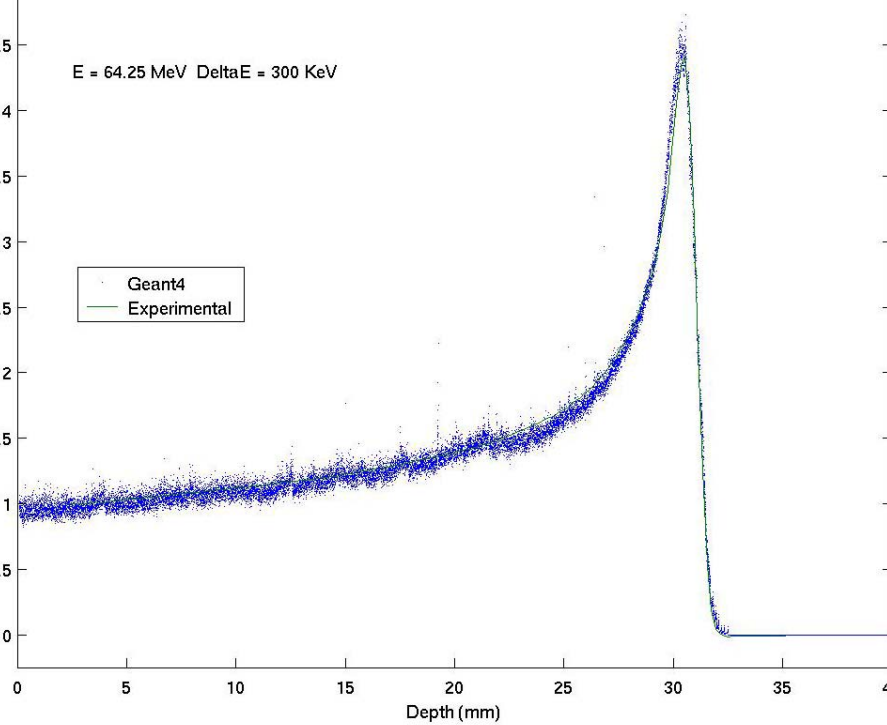

Bragg peaks at different energies

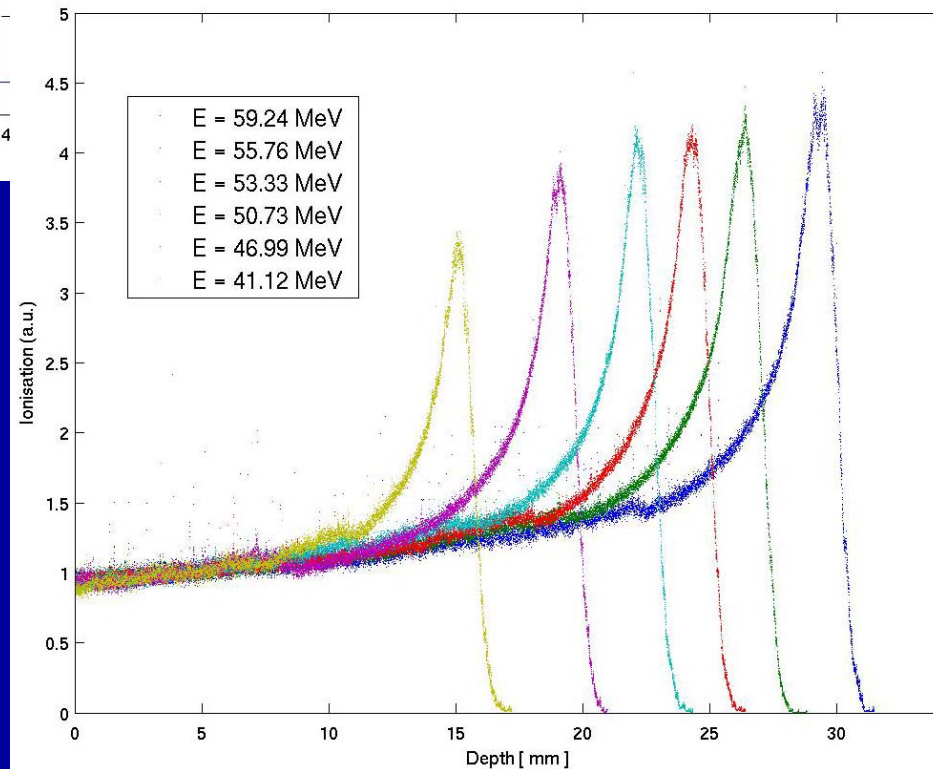

Experimental Data Comparison

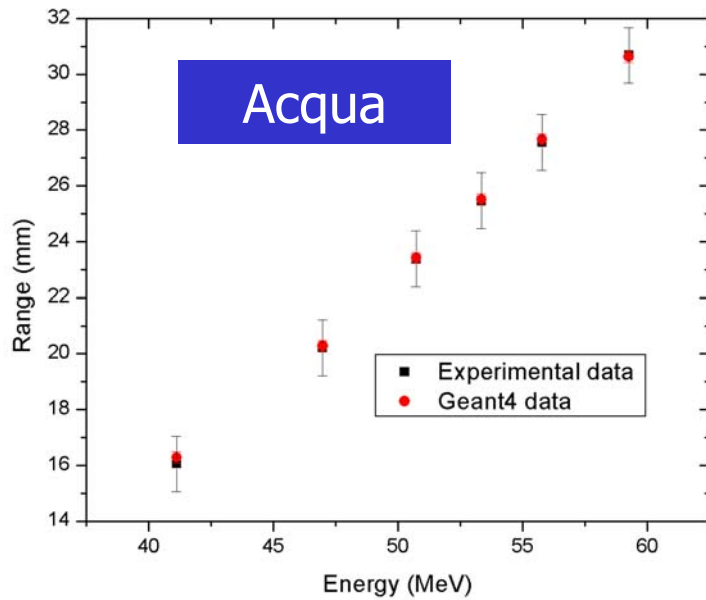

Kolmogorov test

materiale	P-value	test
Acqua	0.9876	Accettato
Rame	0.999	Accettato

Simulated and experimental range in water and copper

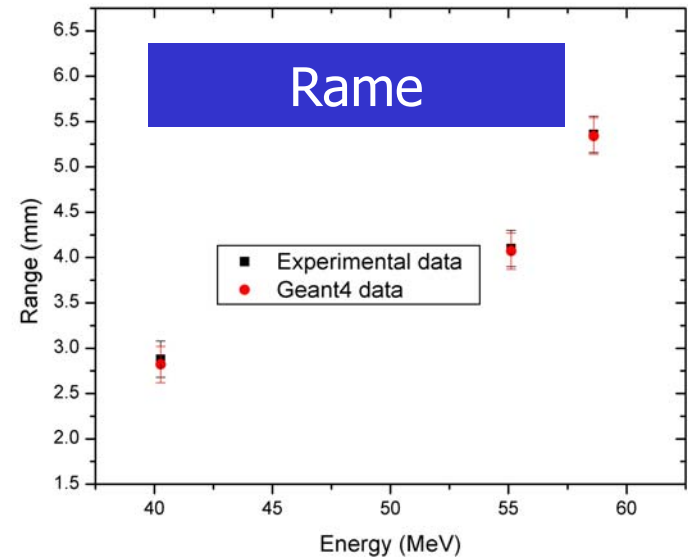

Lateral Distribution: comparison With experimental data

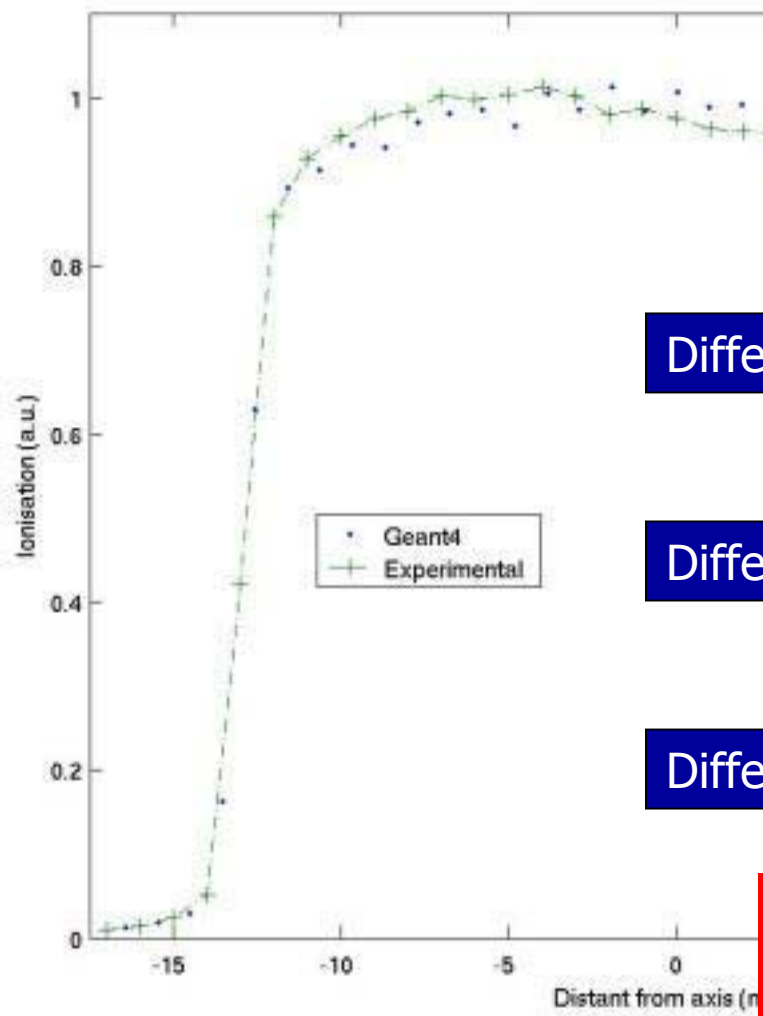

Difference in penumbra = 0.5 %

Difference in FWHM = 0.5 %

Difference Max in the homogeneity region = 2 %

Kolmogorov test:
 $\chi^2 = 0.011, p = 0.97, \nu = 2$

Monte Carlo examples
to study and
improve the
transport beam line

H.Paganetti, Monte Carlo method to study the proton fluence for treatment planning
Med. Phys. 25, 1998

Study of the influence
in the dose distribution

PHASE SPACE DISTRIBUTION
reporten versus the
plan transversal to the beam direction

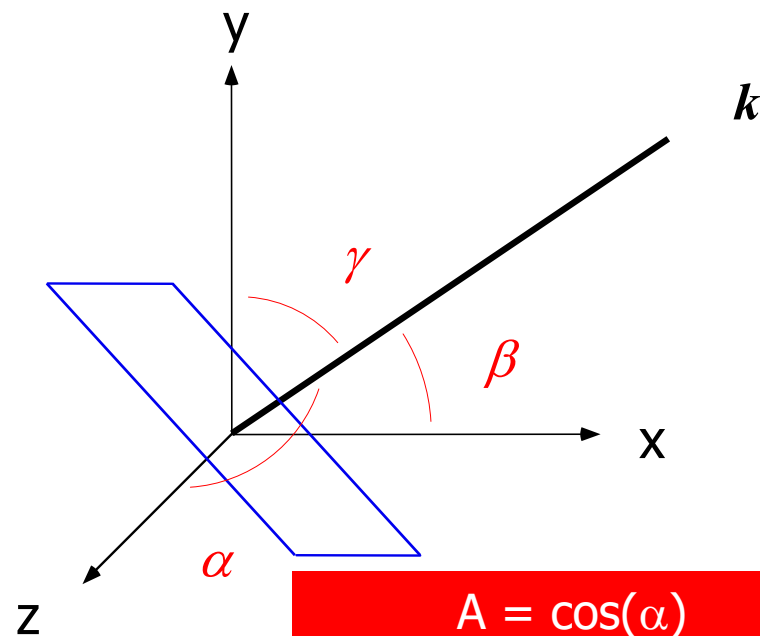

$A = \cos(\alpha)$
 $B = \cos(\beta)$
 $C = \cos(\gamma)$

Phase space distribution along the transport beam line in Catania

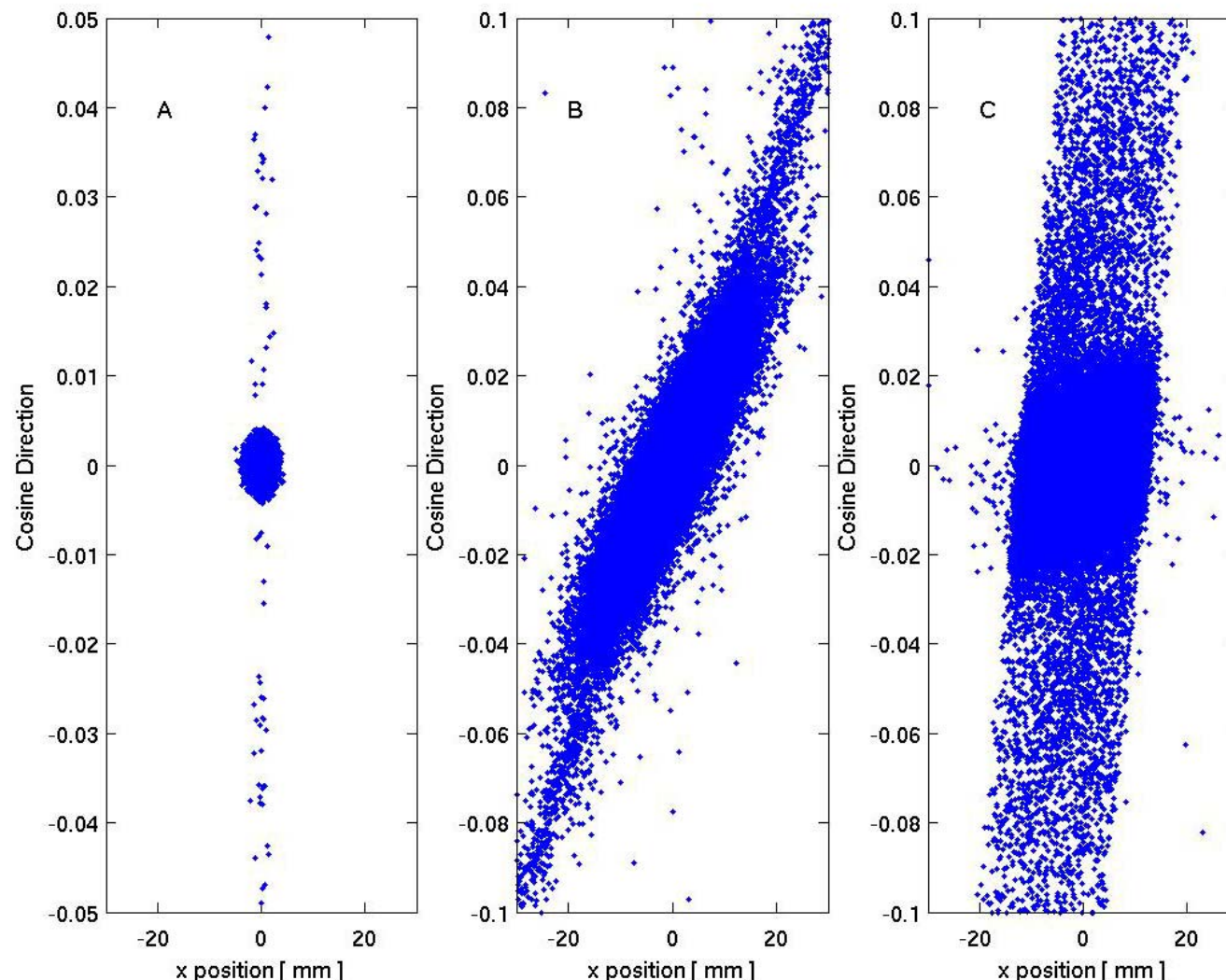

Lateral distribution in the phase space distribution

Initial beam

Isocenter
(patient location)

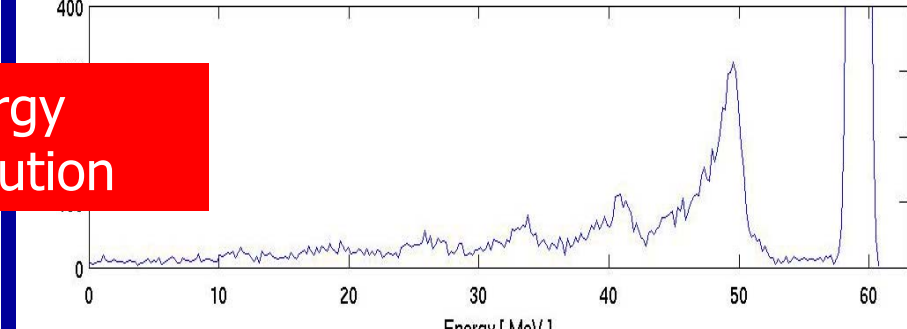
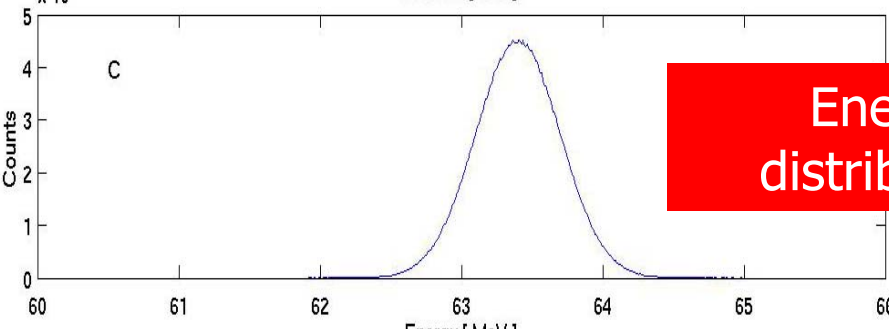
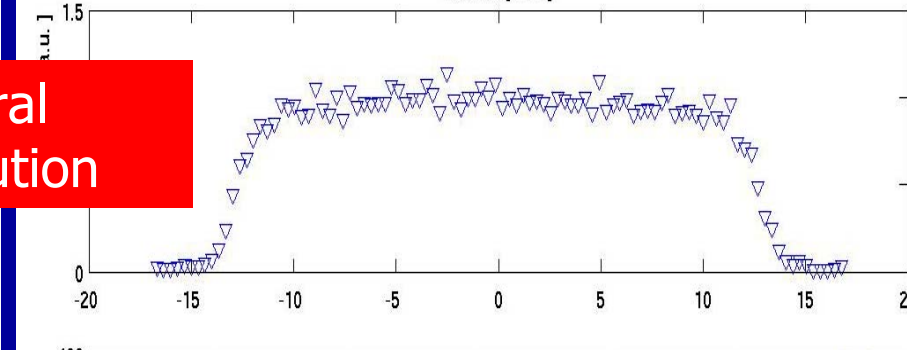
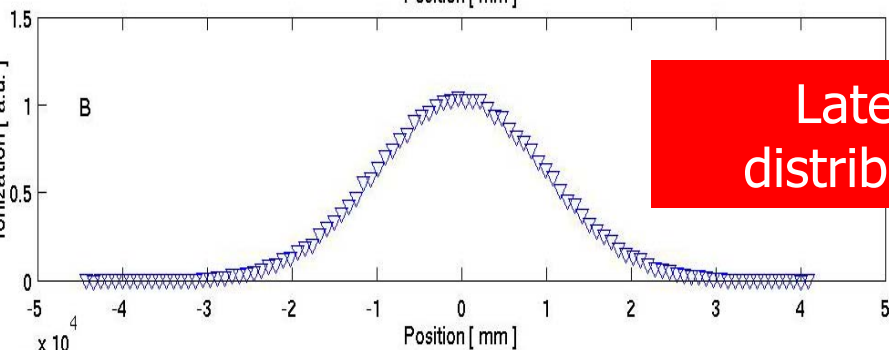
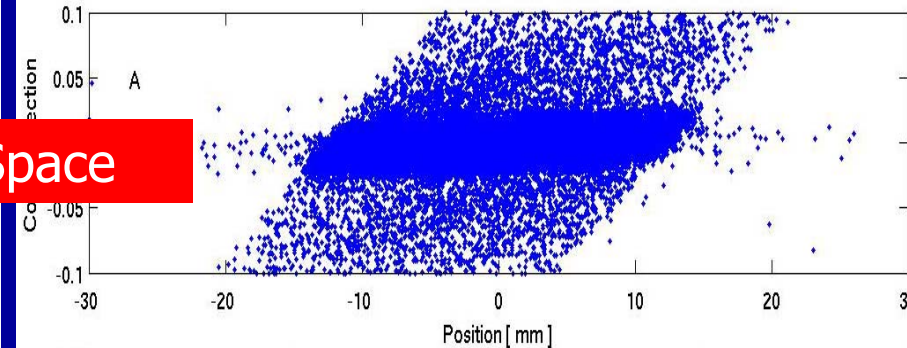
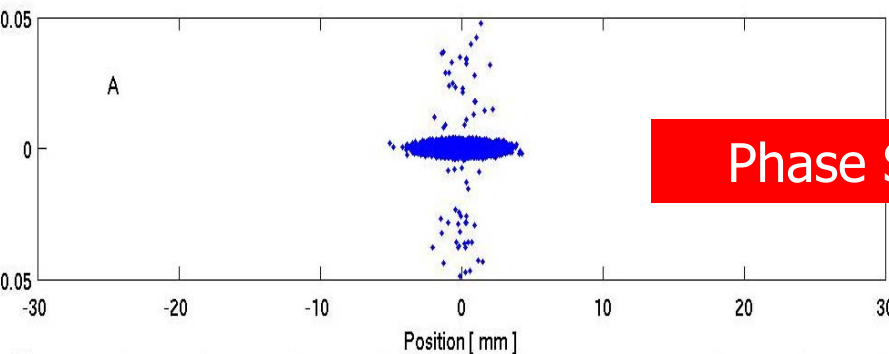

Lateral distribution in the phase space distribution

A variation of a beam element along beam line can be studied with Monte Carlo studying phase space distributions: conventional dosimeter cannot be so sensible

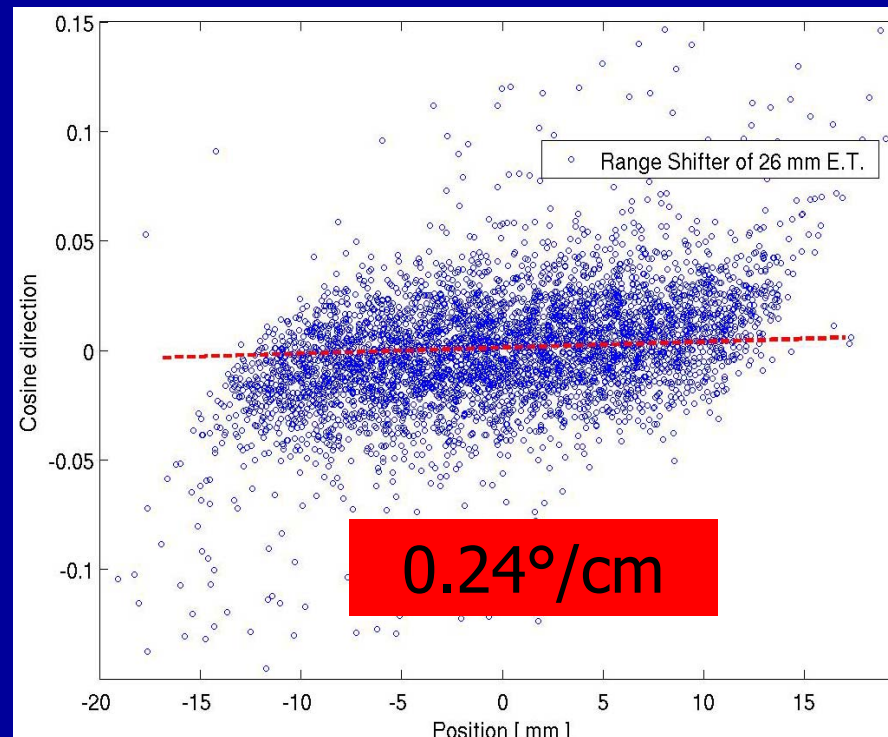
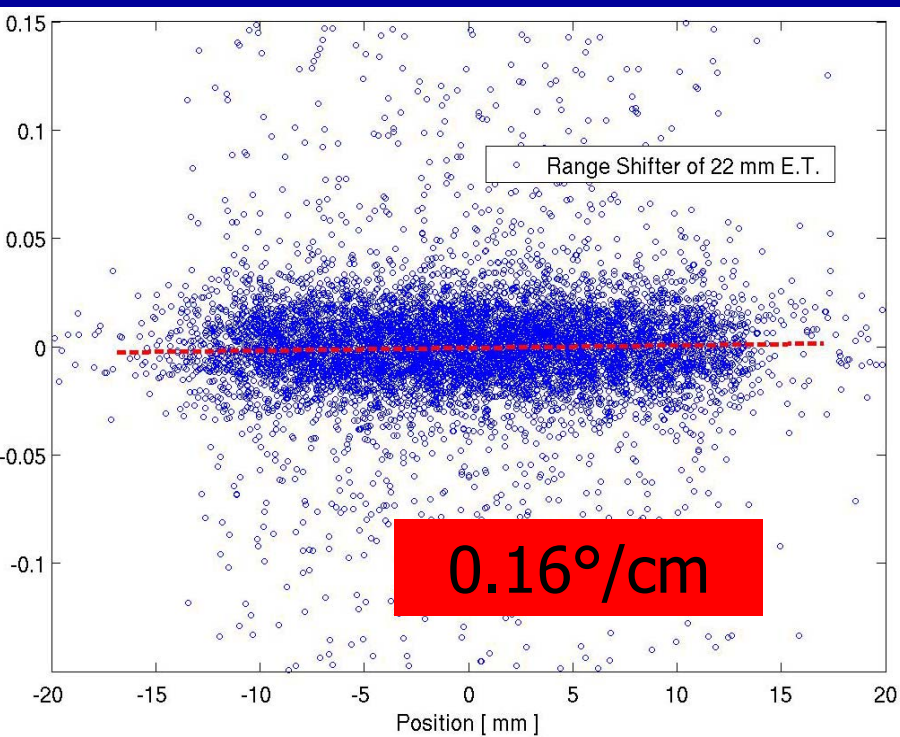

Dose distributions inside patients

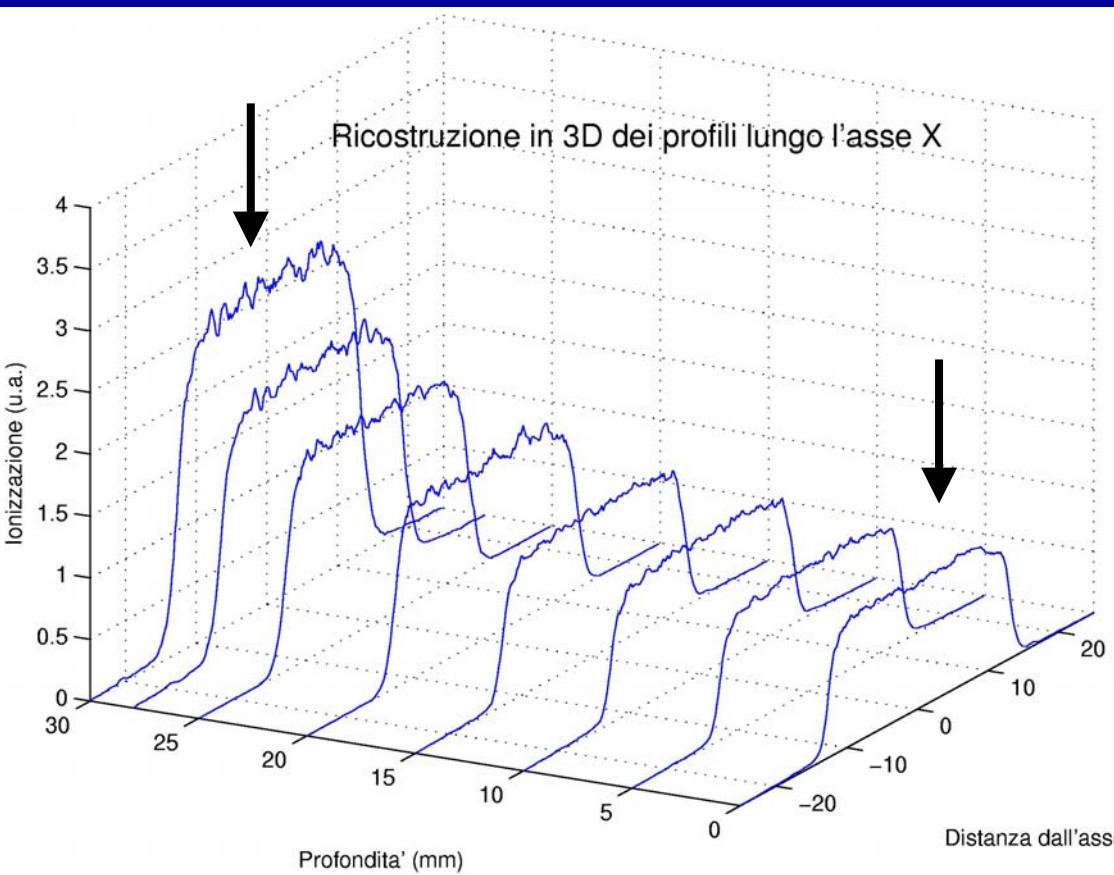

For our proton beam line penumbra increases up to 34%

Energy sigma increases up to 83%



Modulator s
reconstructi

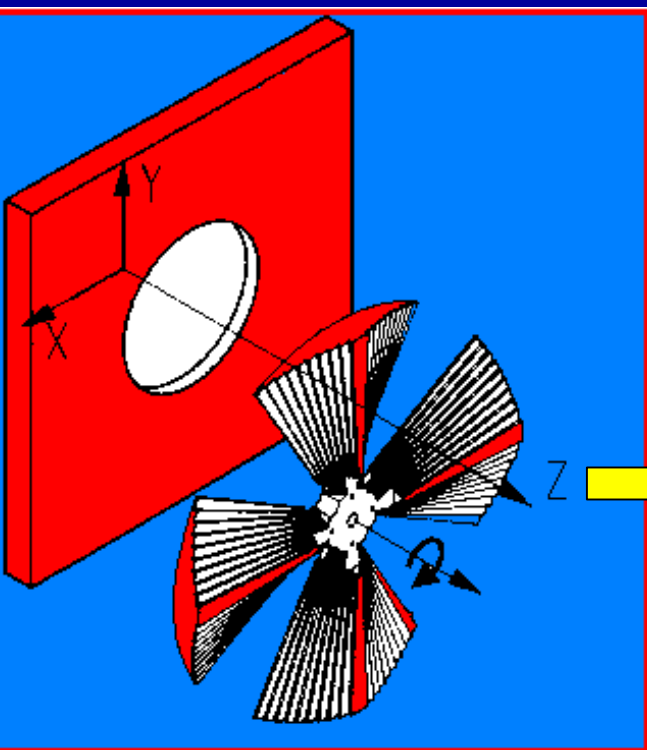

Geant4 Modulator we
simulated next weex

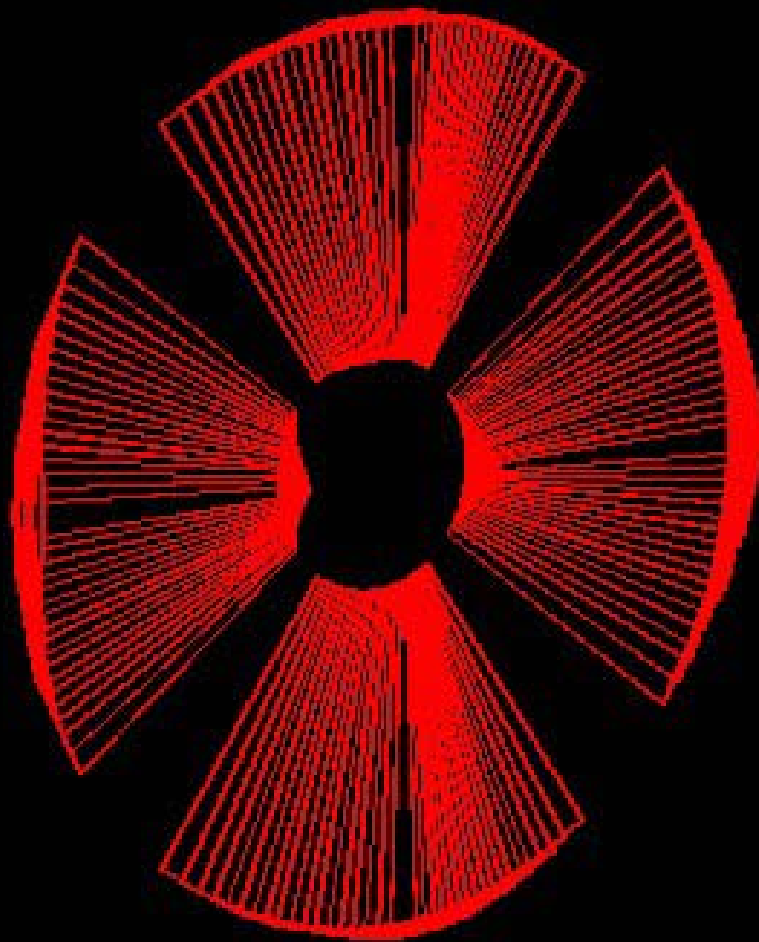

Monte Carlo in the clinical practice can be limited by the long calculation times

On the other hand *velocity* is mandatory for a medical physicist and a medical doctor when they are to plan a treatment

*GRID technologies could represent a solution
see the talk of Giorgio Russo*

Feature Developments



DICOM images insertion



More realistic dose distributions



Statistical comparison between analytical based treatment planning systems

We decided to start this work with the Clatterbridge center for oncology where the EYEPLAN TPS system was developed and now maintained

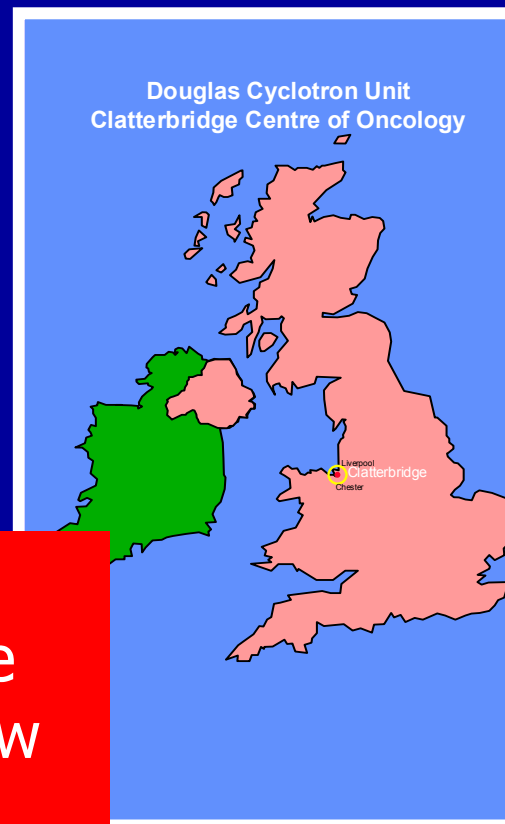

Feature Developments



Low Energy range measurements (5 MeV – 100 KeV)

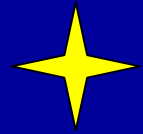

We are studying different Hadronic models and the nuclear components to the released dose for proton and carbon



In the next week we'll compare a bragg peak for a 62 MeV Carbon beam with GEANT4 simulation

The Sicilian Center for Hadron Therapy

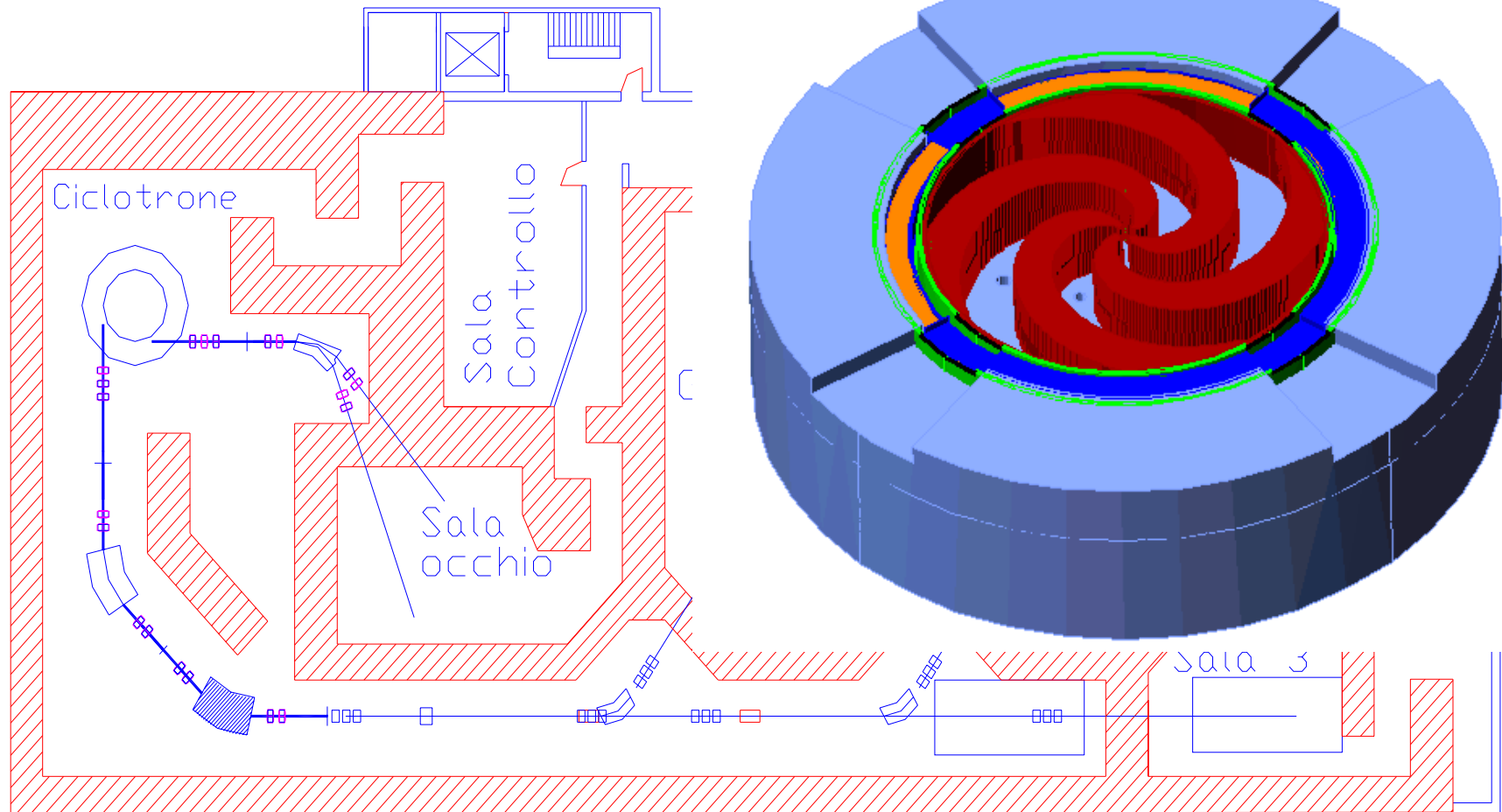

250 MeV for protons, 1500 MeV for Litium and 3000 MeV for Carbon Ions

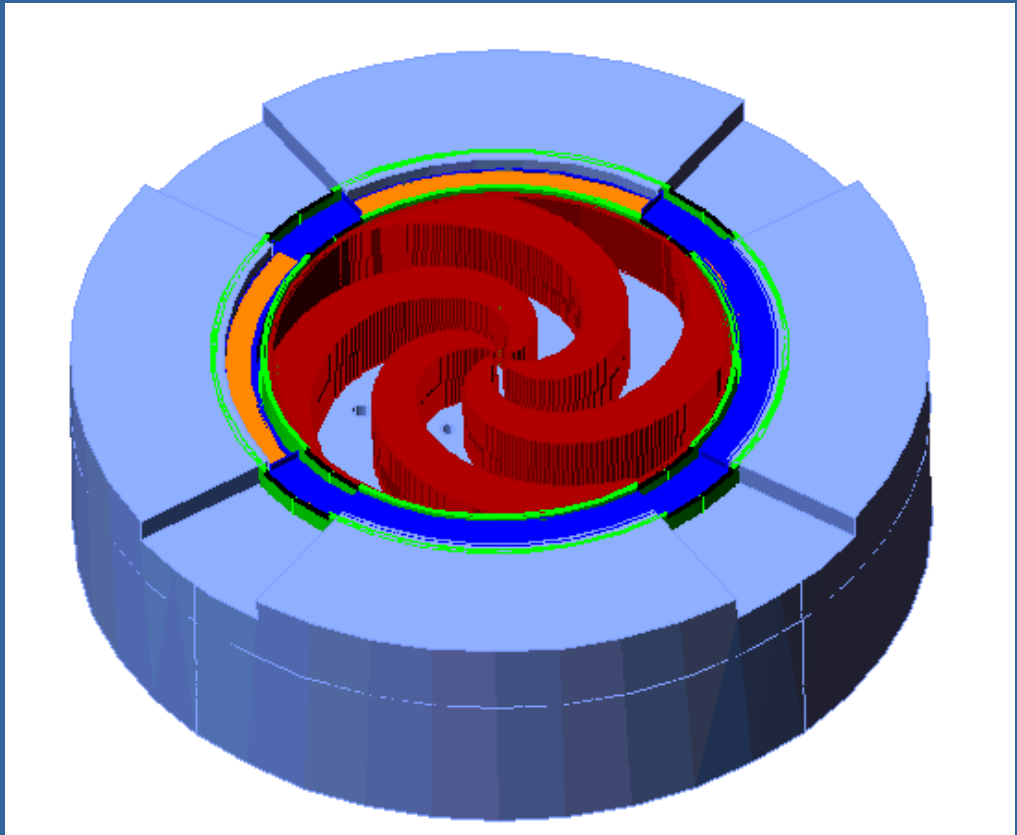

Design di hadron therapy

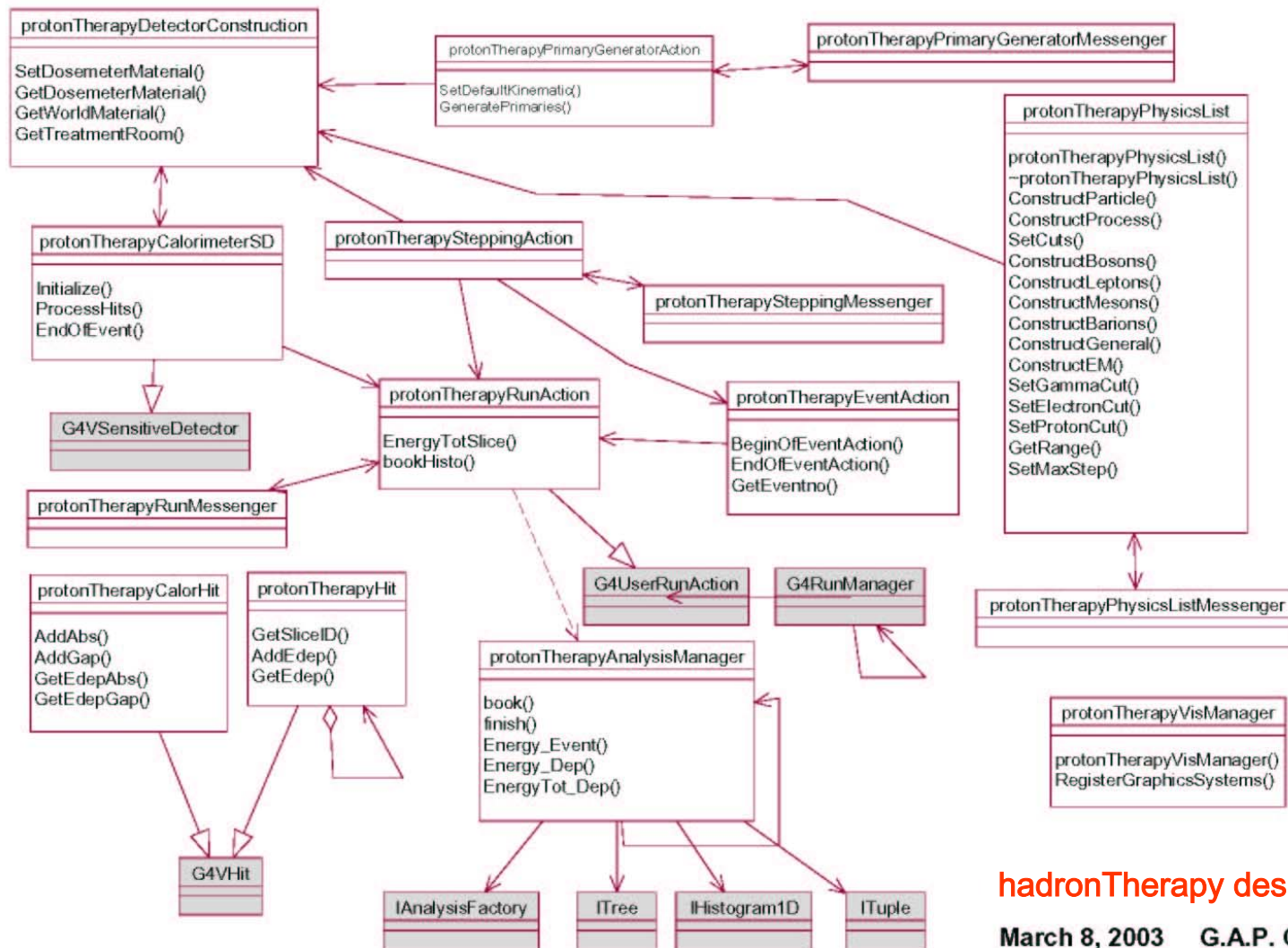

hadronTherapy design

March 8, 2003 G.A.P. Cirrone

Caratteristiche del fascio primario simulato

Sulla base dei dati sperimentali e delle caratteristiche dell'acceleratore superconduttore:

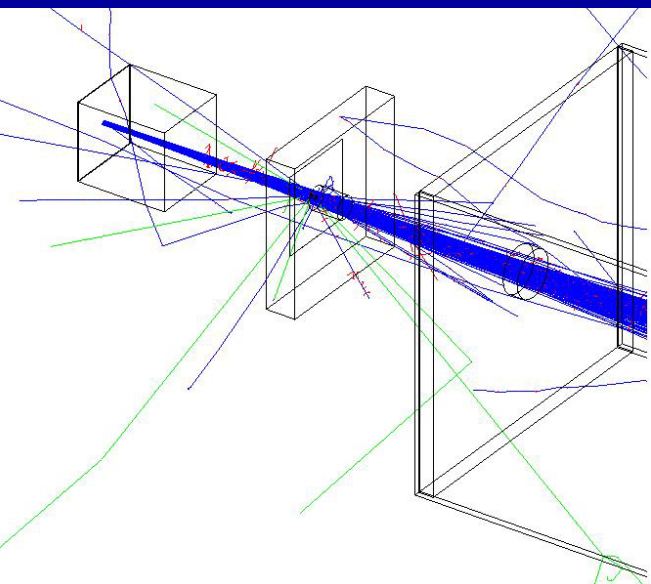
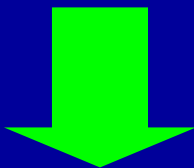

Energia Iniziale	63.4 MeV
δE	300 keV
σ Posizione	1 mm
σ Momento	0.0001

Sulla base delle curve di Bragg sperimentali abbiamo definito le caratteristiche iniziali del fascio di protoni

- Energia
- *Spread* in energia
- Distribuzione spaziale
- Distribuzione dei momenti

"Fotografia" del fascio all'isocentro

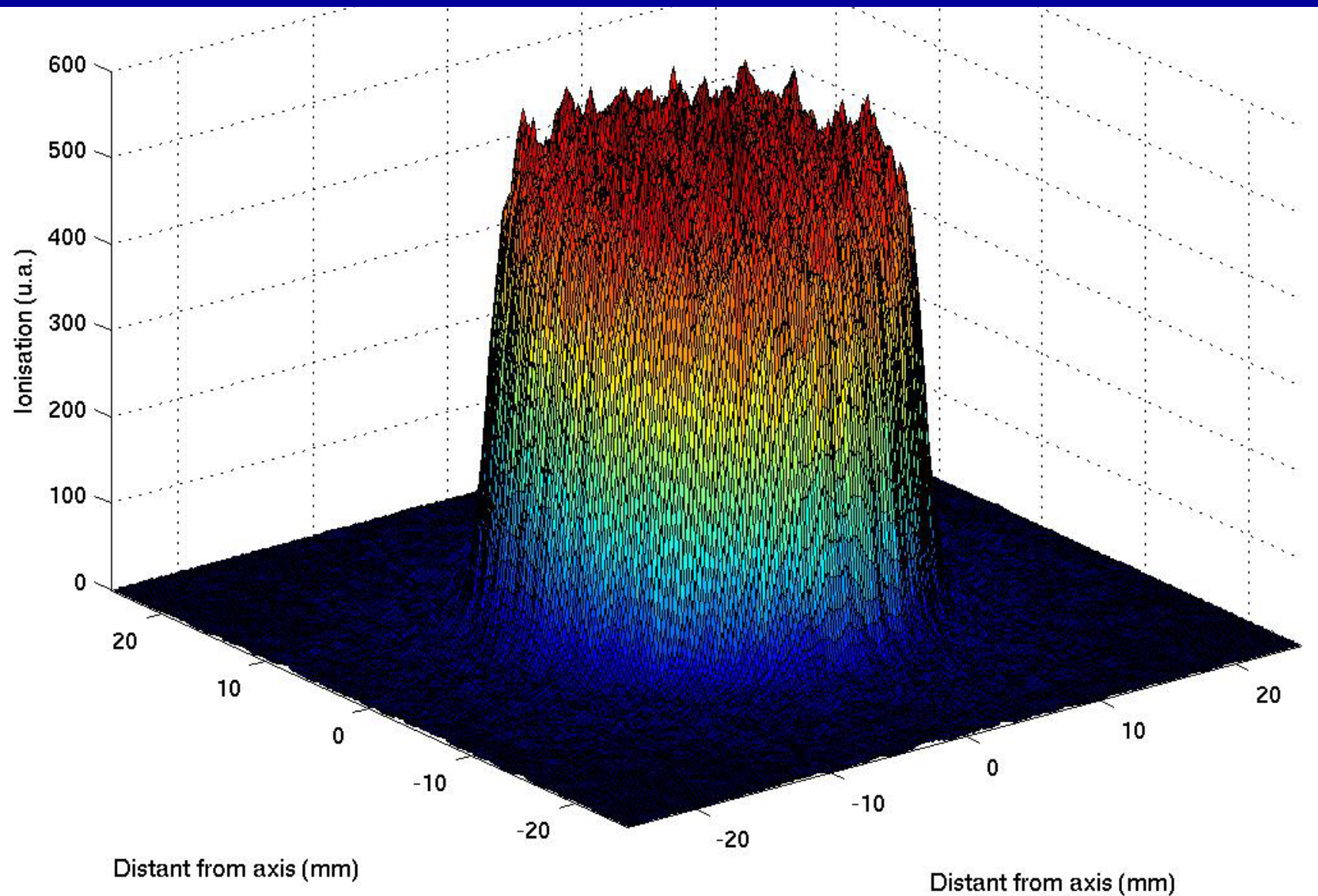

La terapia con adroni è considerata ancora oggi una tecnica pionieristica

Numerosi centri in Europa si svilupperanno nei prossimi anni:

- RPTC, Munich Germania
- PSI, Villigen Svizzera
- Trento, Italia
- TERA, Italia
- Heidelberg/GSI, Darmstadt Germania
- Centro di Adroterapia, Catania Italia

- Codice Trasparente (open source)
- Librerie specifiche per i processi fisici alle basse energie e per i processi adronici
- Tecnologia Object Oriented
- Numerose validazioni del software
- Supporto On-Line
- Interfacce User Friendly
- Interattività

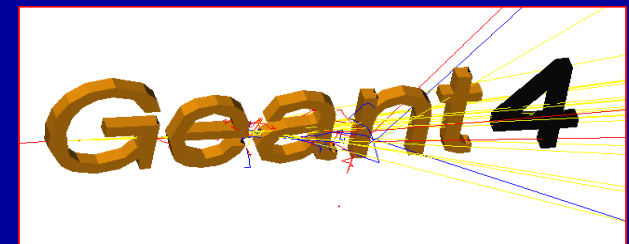

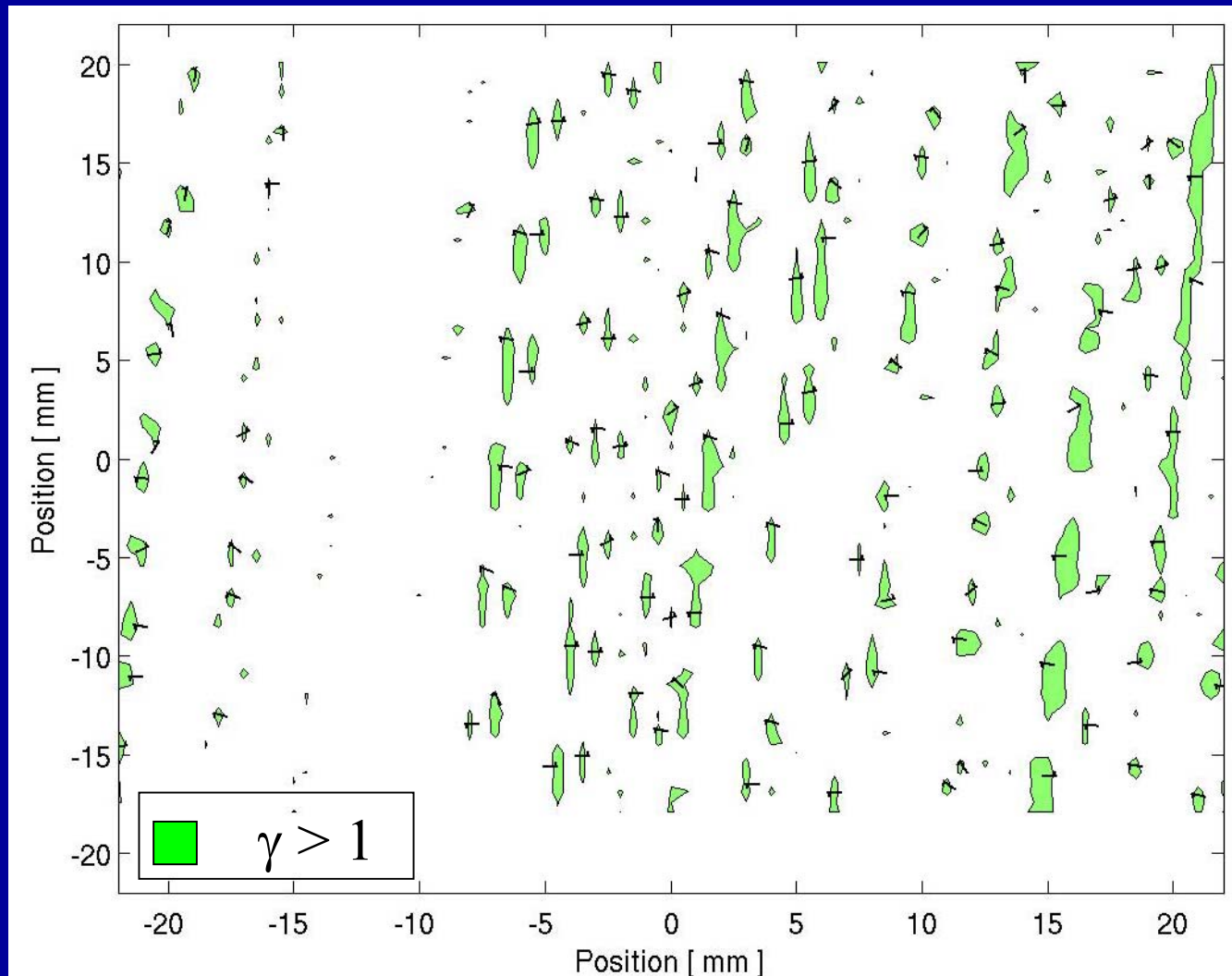

Distribuzione delle iso-gamma nelle regioni per le quali il test fallisce

Validazione del programma sviluppato



Confronto dei parametri di interesse medico con i dati sperimentali.

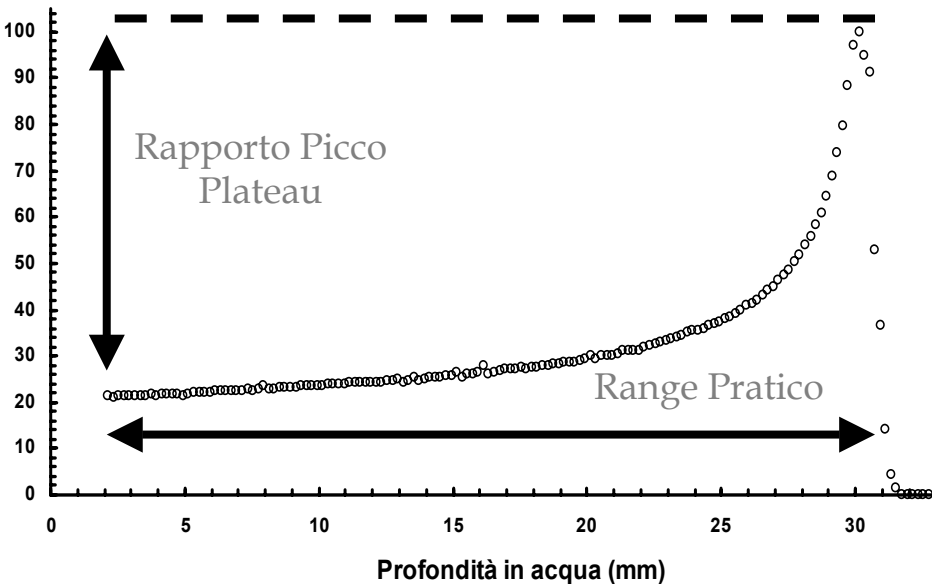
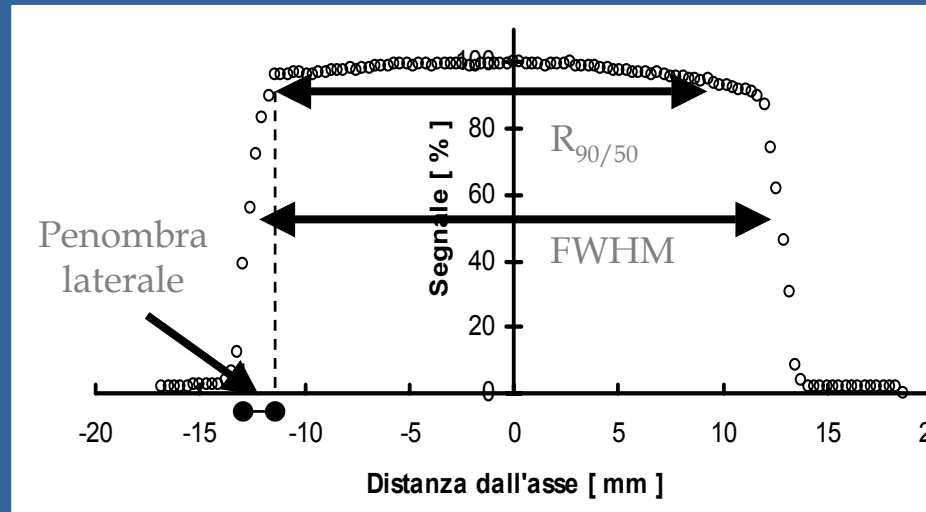

Curva di Bragg

- ★ Range Pratico
 - ★ Rapporto picco-plateau
- Distribuzione spaziale del fascio di protoni
- ★ Penombra Laterale
 - ★ FWHM
 - ★ $R_{90/50}$

Dati sperimentali: distribuzioni di dose in profondità

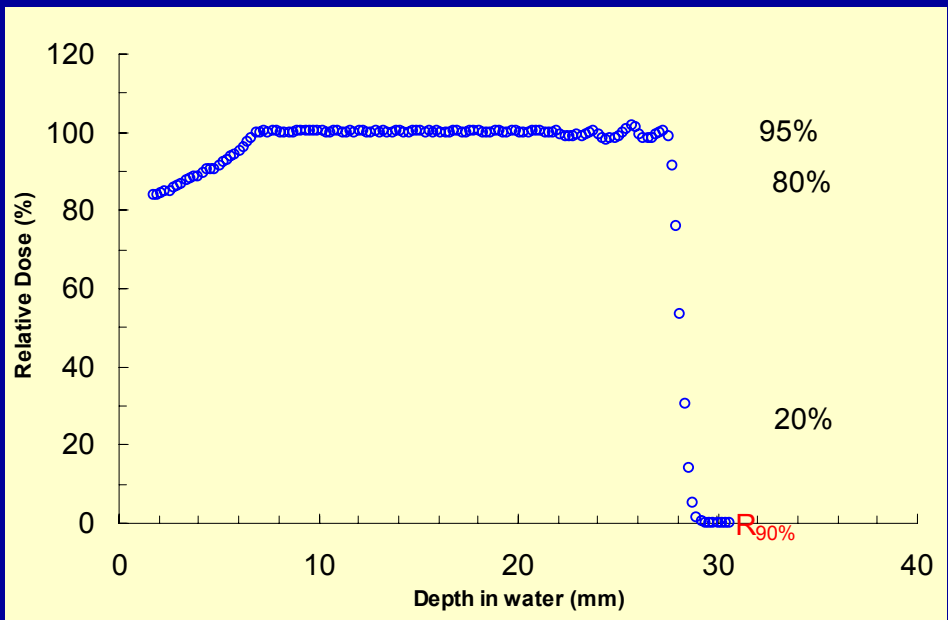
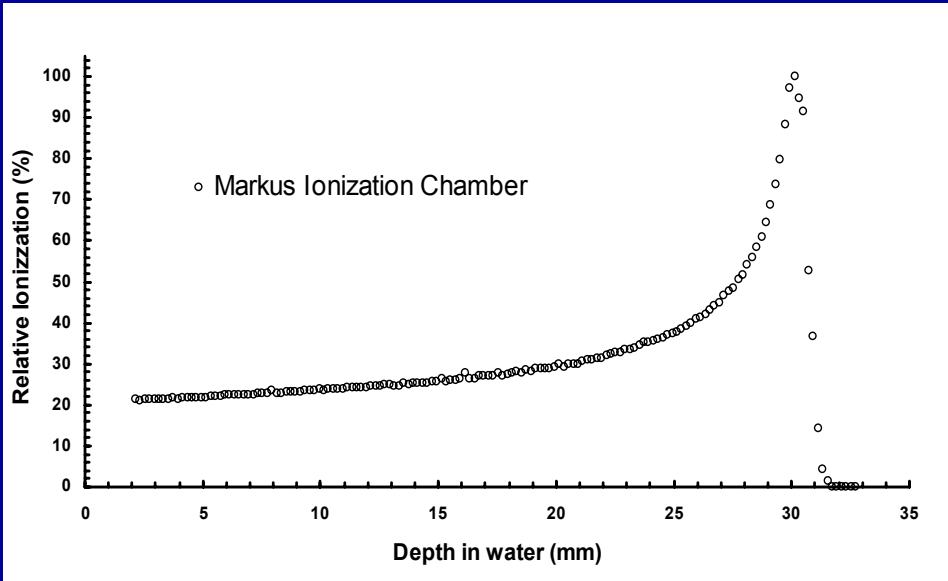

Elementi tipici di una linea di protonterapia

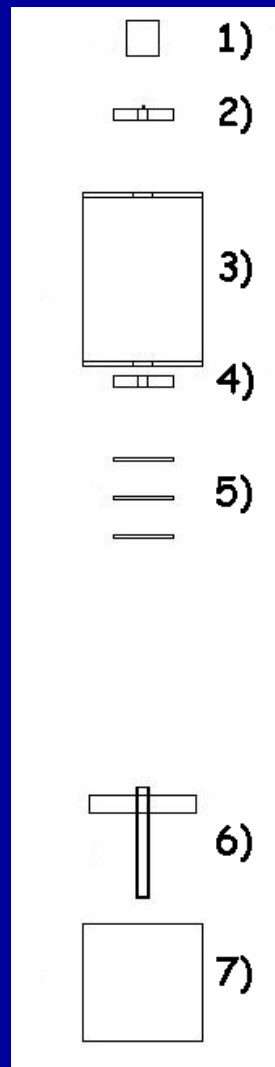

1. Primo diffusore
 2. Secondo diffusore, stopper di ottone
 3. Camera con il modulatore
 4. Collimatore
 5. Camere Monitor
 6. Collimatore finale e del paziente
 7. Cubo contenente il rivelatore sensibile
- Sistema di diffusione

Maggiore trasparenza rispetto agli altri codici
nei processi fisici implementati

Processi fisici implementati In hadronTherapy

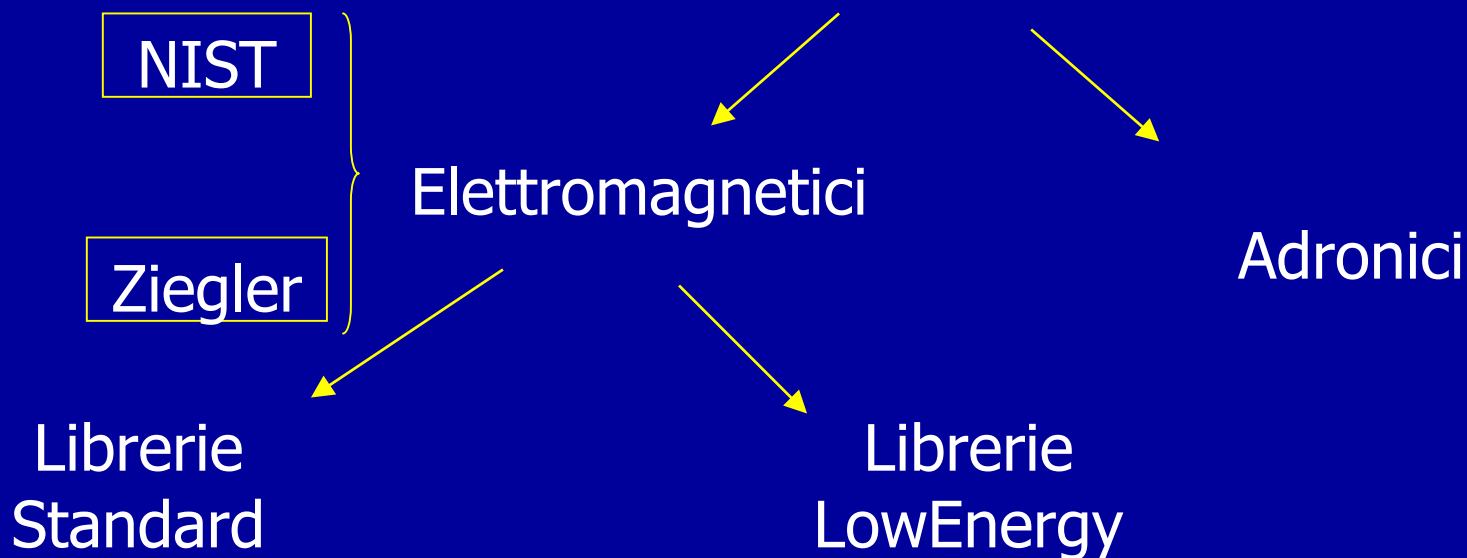

1 PeV – 1 keV per fotoni ed elettroni
1 PeV – 10 keV per protoni e ioni

100 GeV – 250 eV per fotoni ed elettroni
100 GeV – 1 keV per protoni e ioni