

USE OF GEANT4 FOR LHCb RICH SIMULATION

S. Easo,
RAL, 5-7-2001

- LHCb AND ITS RICH DETECTORS.
- TESTBEAM DATA FOR LHCb-RICH.
- OVERVIEW OF GEANT4 SIMULATION.
- DESCRIPTION AND VERIFICATION OF SIMULATION.
- RESULTS ON PHOTOELECTRON YIELD.
- SUMMARY AND PROSPECTS.

Introduction to LHCb and its RICH Detectors

- LHCb : Precision Measurements of CP Asymmetries in B-Decays.
- Particle ID: Essential component of LHCb. Ex: Separate Pions and Kaons in data.
 - Signal: $B_d \rightarrow \pi^+ \pi^-$. Backgrounds: $B_d \rightarrow K^+ \pi^-$,
 $B_s \rightarrow K^+ \pi^-$,
 $B_s \rightarrow K^+ K^-$.
 - Signal: $B_s \rightarrow D_s^+ K^-$ Background: $B_s \rightarrow D_s^+ \pi^-$.

LHCb Detector

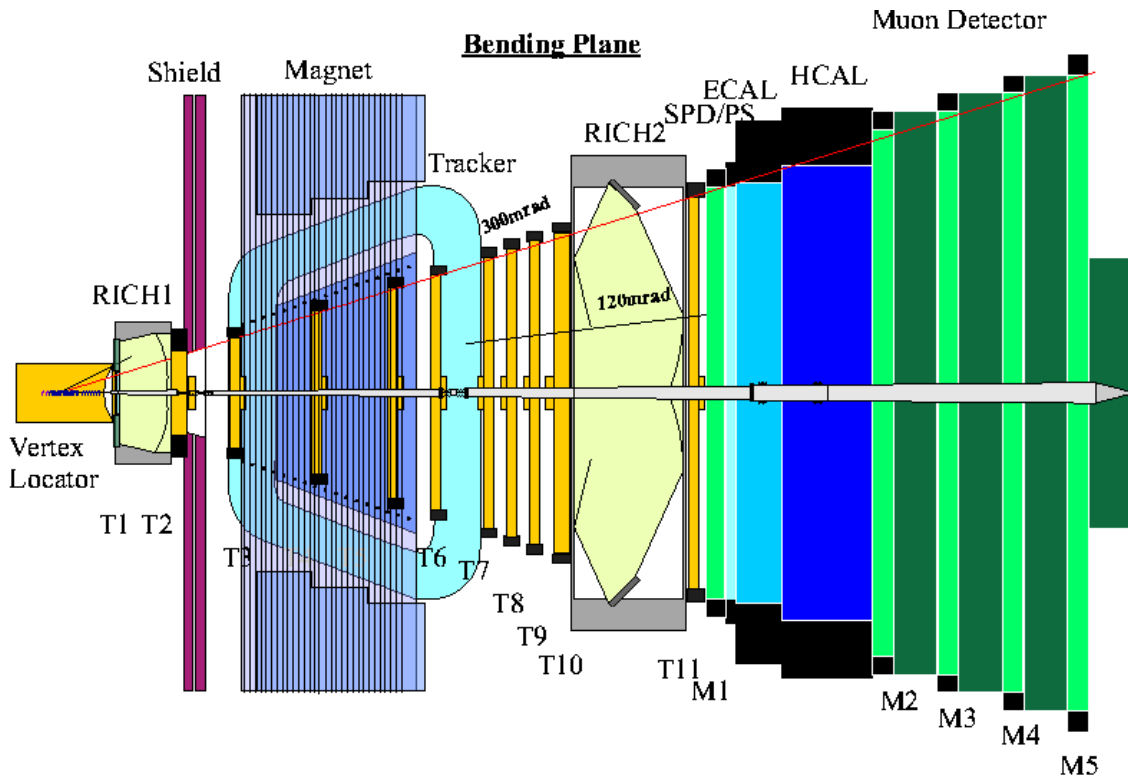

- Two RICH detectors covering polar angles 10 - 330 mrad.
- Upstream Detector, RICH1 : Aerogel + C_4F_{10} for momentum 1- 65 GeV/c.
- Downstream Detector, RICH2: CF_4 for particles upto 100 GeV/c.
- Combination of Tilted Spherical mirrors and plane mirrors.
- Photon Detection: HPDs which cross-focus electrons on Silicon pixel detectors.
- HPD coverage 2.9 sq. meters : granularity 2.5 sq. mm, 340000 channels.

RICH TESTBEAM SETUP

Cherenkov Ring at Focal Plane

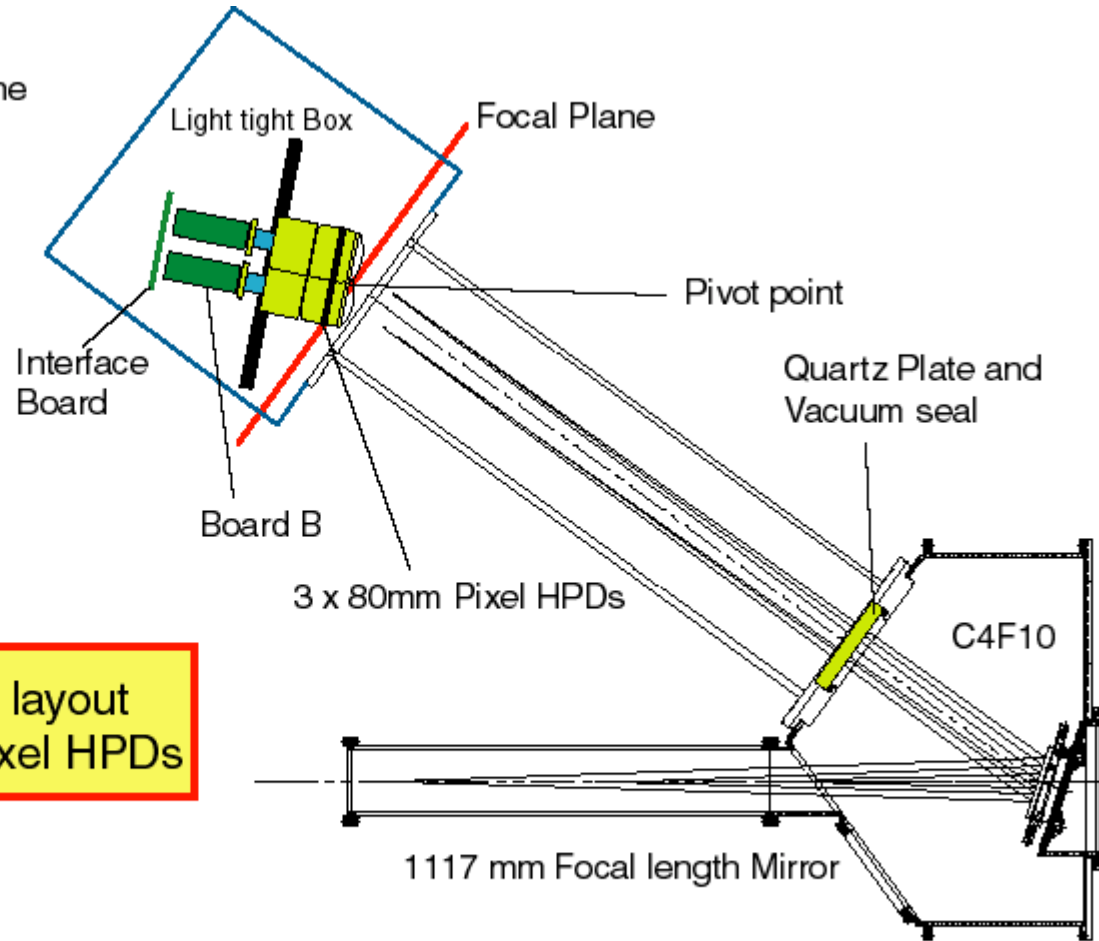
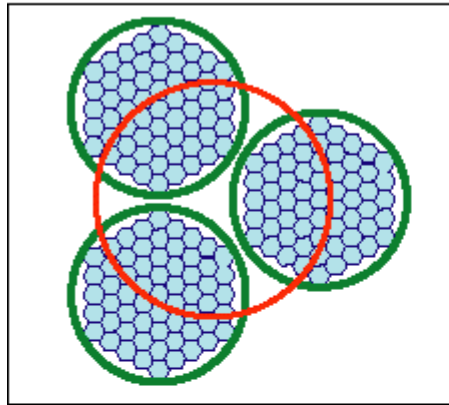

Sketch of prototype layout
for cluster test of Pixel HPDs

Cherenkov angle is 53 mrad with C4F10 radiator at 1000mbar

TESTBEAM DATA SET

- Data Taken in June 1999.
- RICH1 Geometry, C410 Radiator, 120 GeV/c Pion(-) Beam.
- Three 80 mm Hpds with 61- pixel Silicon Anodes.
- Analogue Readout.
- Run Used: Pressure= 164 mbar, Temp = 19 degree C.
(ring entirely on one of the HPDs).
- Results from data Analysis and Fortran Simulation are
in an LHCb internal note and are quoted in the RICH TDR.

OVERVIEW OF THE SIMULATION

Simulation: GEANT4
Graphics: OPENGL

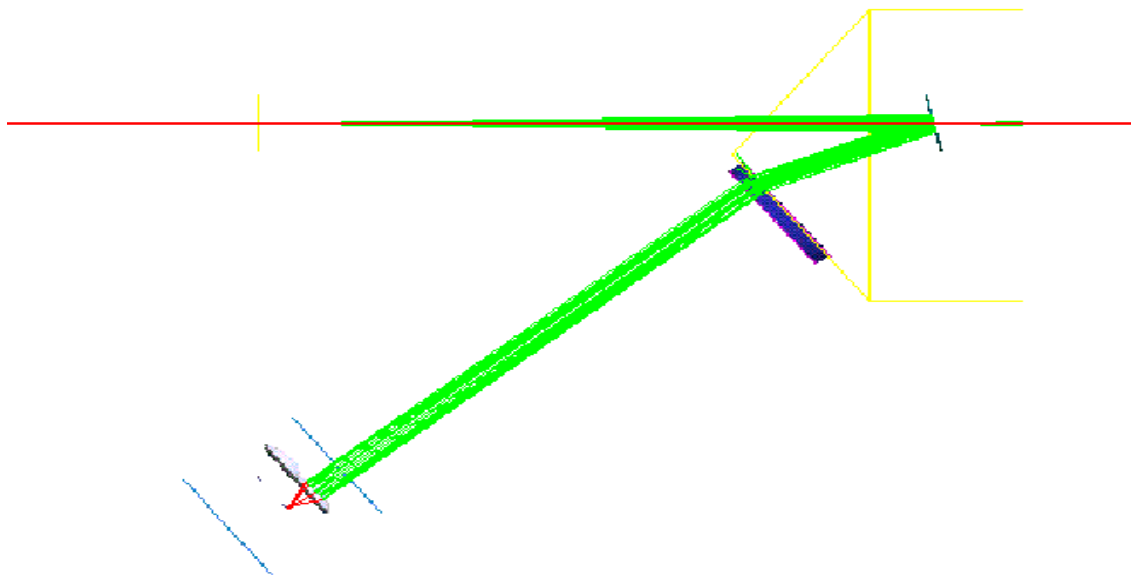

OVERVIEW OF THE GEANT4 SIMULATION

- I used the standard GEANT4 procedures as much as possible.
- Some of the GEANT4 ‘Physics Processes’ depend on the atomic properties of the materials used in the program.
- Certain ‘process customizations’ were necessary for simulating specific aspects of the RICH Test Beam Detector. I shall be describing these during this presentation.
- All Histograms from GEANT4 are made using LIZARD.
- **The main parts of the Simulation procedure are:**
Photon Generation, Photon transportation,
Photoelectron generation and creation of hits by the electrons.

Generation of Photons

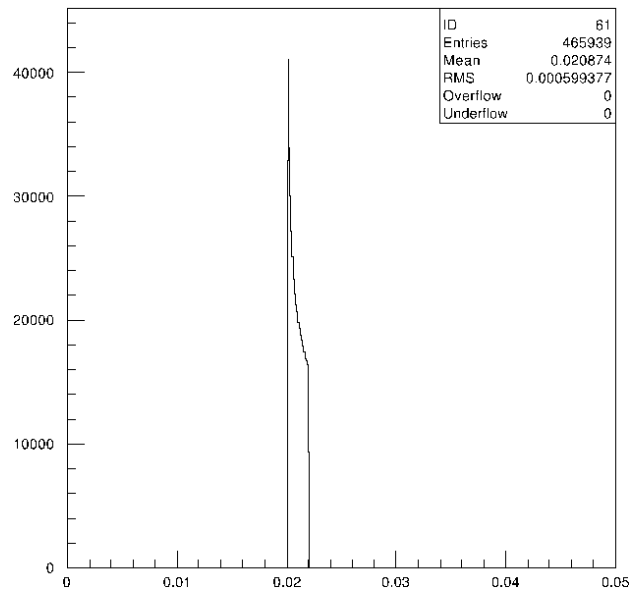

Cherenkov Angle in Radians
at Photon Generation.

- Some of the photons generated, are killed before they reach the Photo Detector by processes which depend on the Photon energy.

Mean in Simulation=20.87 mrad.

(Using HERA-B parametrization
for Ref. Index of C4F10)

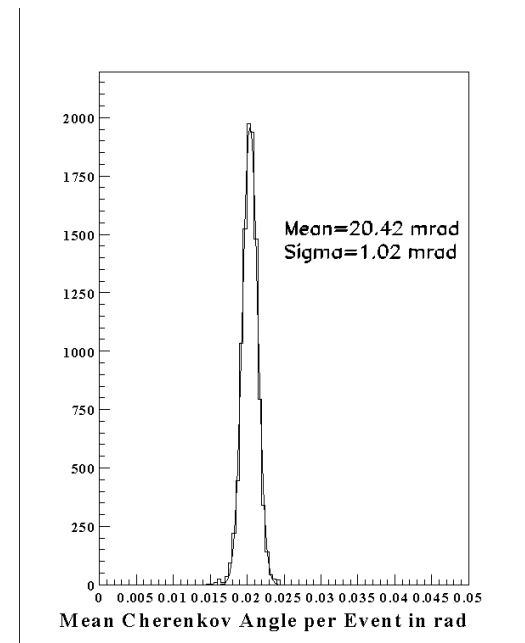

In Real Data:

Cherenkov Angle=20.42 \pm 1.02mrad

Optical Reflection at the Mirror

Number
of Photons

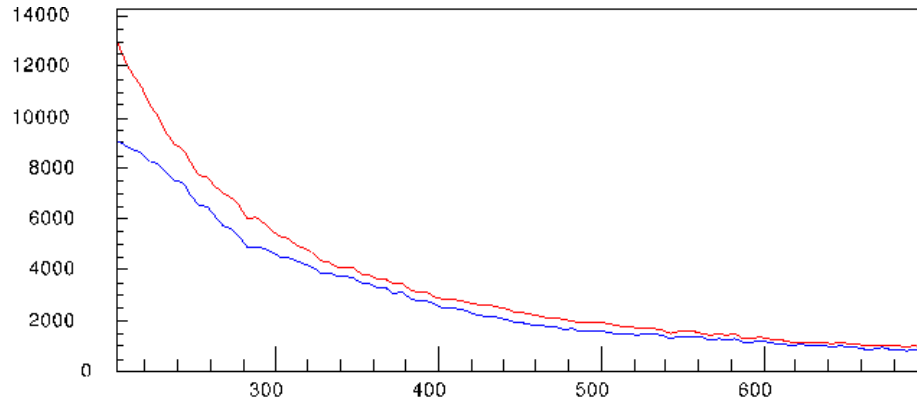

Red: Photons Before
Reflection at Mirror.
Blue: Photons After
Reflection at Mirror.

nm

Ratio:
Blue/Red

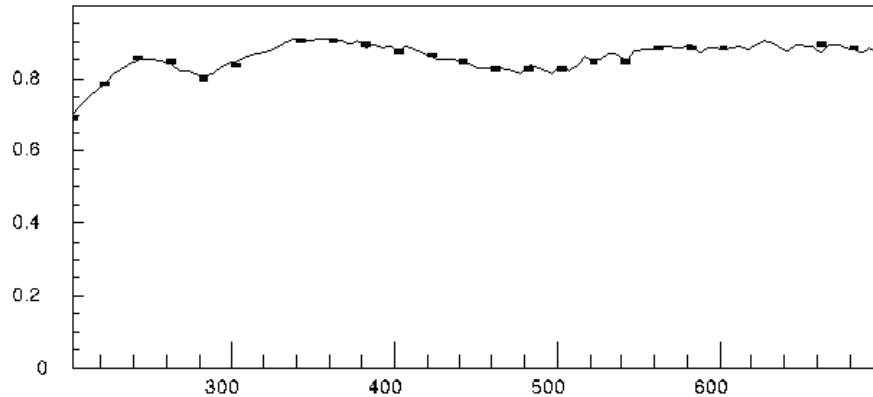

Solid Curve:
After Mirror/Before Mirror.

Dots: Mirror Reflectivity.

nm

Photon Wave Length in nm

Optical Transmission Through Quartz

Red: Photons before entering Quartz.

Blue: Photons just before exiting quartz.

Number
of Photons

Loss from Reflection
at Quartz Entrance
and from Transmission.

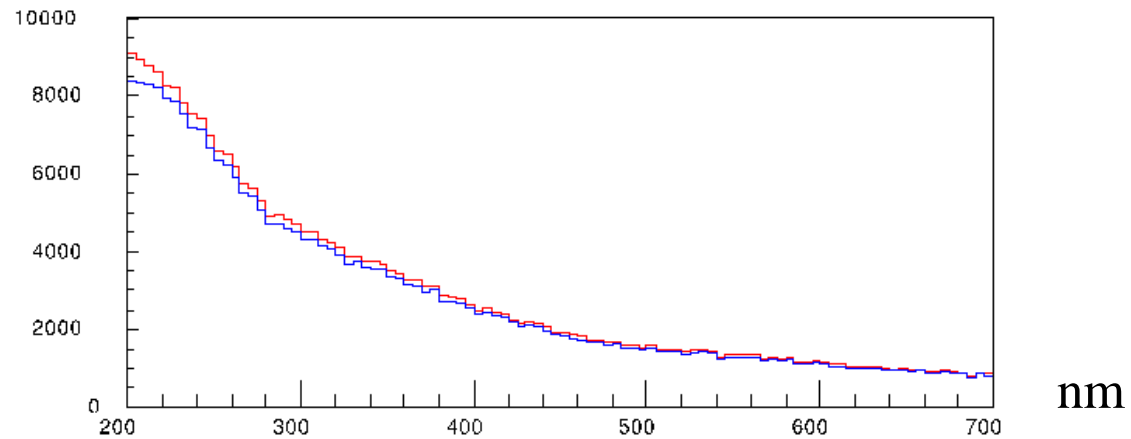

Ratio:
Blue/Red

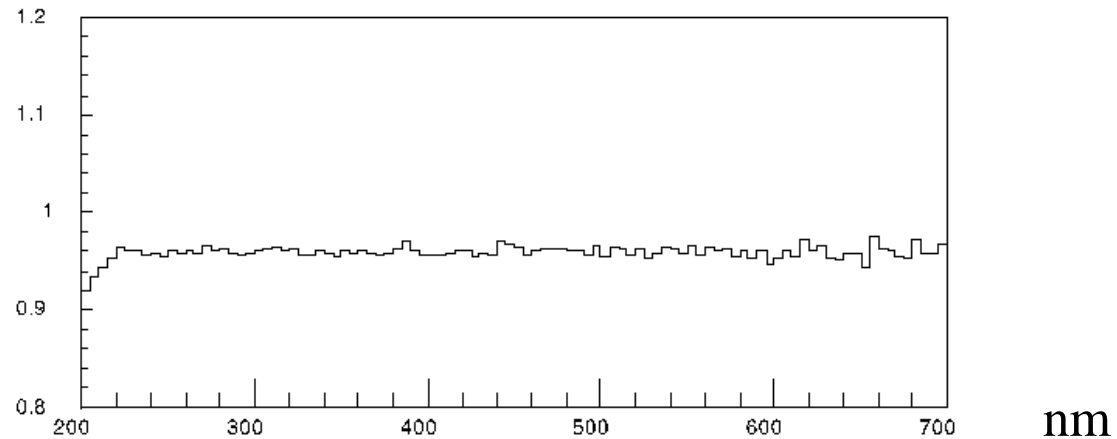

Photon Wave Length in nm

HPD Simulation

- We have the data for the Quantum Efficiency and the data for parametrizing the cross-focussing of the photoelectrons.
- The Standard Geant4 Photoelectric process is not suitable for this application. (It relies on the atomic properties of the photocathode.)
- I implemented a process which generates electrons using the above data as input.
(This process is a class derived from the G4DiscreteProcess class.)

HPD SIMULATION

Green Lines: Photons.

Red Lines: Photoelectrons.

Blue Circles: Frame of HPD.

Quartz Window, Photocathode
and Silicon Detector are shown also.

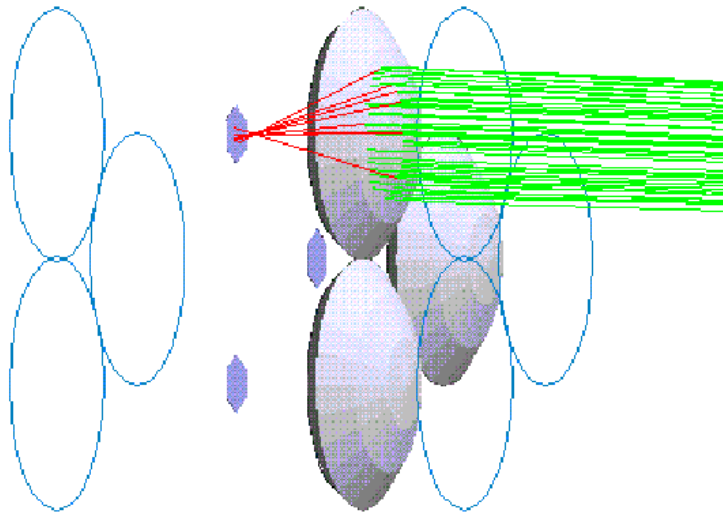

Simulation Picture using OPENGL.

Hpd Photoelectric Effect

Red: Photons incident on Photocathode.
Blue: Photons converted to Photoelectrons.

Number of
Photons

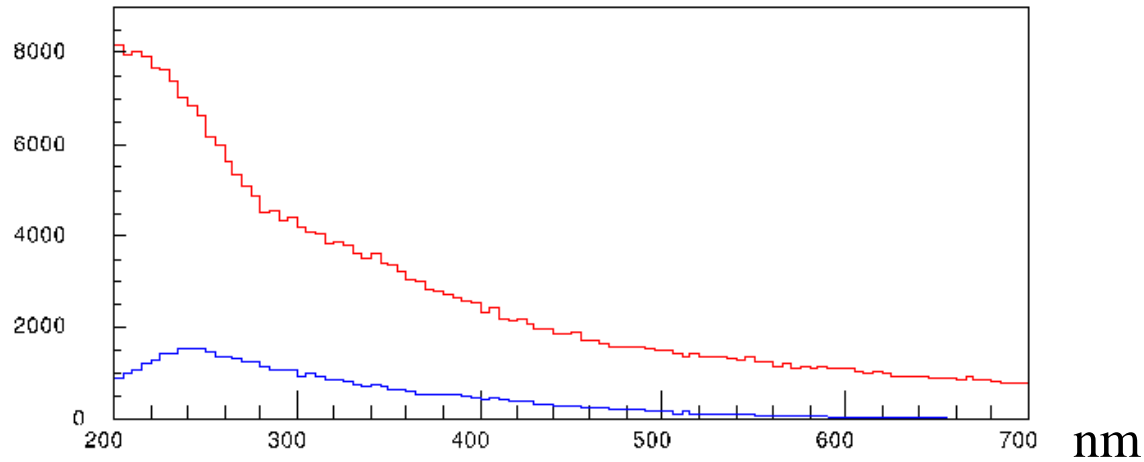

nm

Ratio:
Blue/ Red

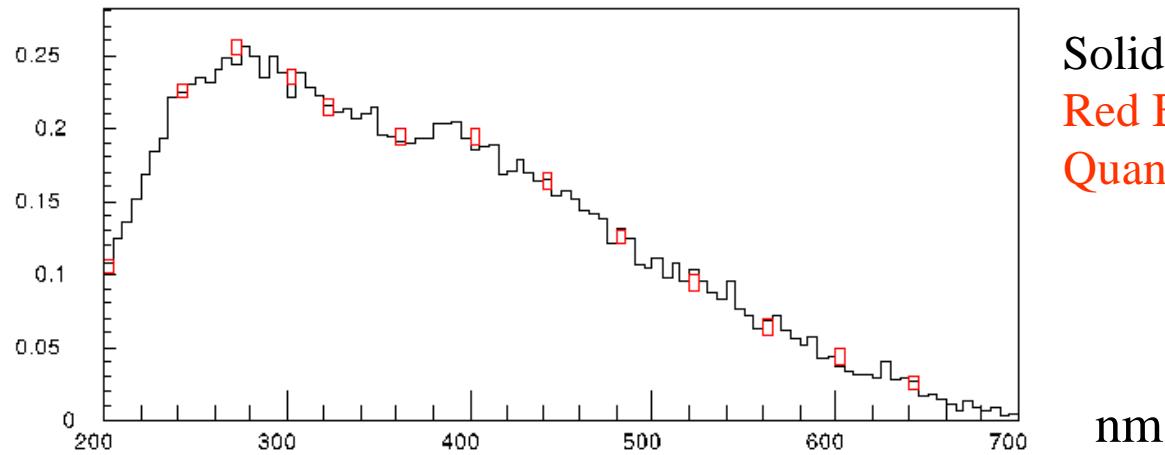

Solid Line: Ratio

Red Boxes:
Quantum Efficiency

nm

Photon Wave Length in nm

HPD Hit creation

- The standard Geant4 Process uses the material properties of Silicon to calculate the energy loss. For the current application, I just wanted to create hits from the photoelectrons which have upto 20 keV/c momentum.
- I created a special simple process for the Hpd Silicon by which, low momentum charged particles loose all their momentum and die. This shall be modified in the future. It also takes care of the effects of backscattering.
- The Silicon pixels are constructed as sensitive volumes in the 'Geant4 ReadOut' geometry so that the standard Geant4 digitization procedure finds the correct pixel hit. (The few dead pixels in the data are kept insensitive).

Preliminary Estimate of Simulation uncertainty

Main sources of uncertainty

	Hpd1	Hpd2
Ref. Index parametrization	0.52	0.48
Quantum Efficiency 5% change	0.44	0.43
Cathode non-uniformity	0.10	0.02
Total	0.69	0.64

Photoelectron Yield

	Real data	GEANT4 Simulation	Fortran Simulation
Hpd1	8.50 ± 0.08	8.67 ± 0.69	8.53 ± 0.61
Hpd 2	7.27 ± 0.04	7.01 ± 0.64	7.19 ± 0.56

Summary and Prospects

- The LHCb-RICH testbeam is simulated using GEANT4.
- The Simulated photoelectron yield agrees with that from data.
- Some of the processes developed for this testbeam simulation are useful for LHCb - RICH detector simulation as well.
- The simulation all the detectors in LHCb is expected to be done using GEANT4 in the GAUDI framework. Hence more interaction between the GEANT4 collaboration and LHCb software group are expected in the future.