

Recent, undergoing and planned ESA- supported activities concerning development, use and promotion of the Geant4 toolkit

E. Daly, R. Nartallo, P. Nieminen

In-house and external developments

- Continuing, detailed development of the XMM-Newton model in Geant4 and the related radiation environment analysis
- Support to the secondary radiation analysis of the OMI instrument onboard the NASA Earth Observing System (EOS) Aura mission
- ESA (SCI-SA) : Students at INFN Genova in the frame of the proposed MXS instrument onboard the Bepi Colombo mission to Mercury
- Contact with CNES and ONERA (F) where Geant4 is actively used for microdosimetry. (Adjoint methods?)
- Transfer of the INTEGRAL mass model into Geant4 by Univ. Southampton. Utilised also by NASA Goddard Space Center

External ESA contracts

- INFN Genova: Development, implementation and use low-energy Geant4 software modules
- DERA: Maintenance of the Geant4 Space Modules
- DERA, SIRA and University of Southampton: Radiation Effects and Analysis Tools (REAT). Interface to Spenvis space environment package; potentially event biasing techniques
- INFN Genova: User requirements for the simulation of the radiation effects in biological systems at the cellular and DNA level
- University of Bern: ESA Standard Radiation Environment Monitor (SREM) and SONTRAC neutron monitor simulations

Soon coming & in preparation

- Two-year (minimum) programme to simulate the radiation fluxes and doses inside the Columbus module of the International Space Station using Geant4
- An open-competition R&D item, with 400 kEURO funds for Geant4 developments, especially for space science missions
- Support for the development of the internal conversion process
- INTAS project, in which 11 Russian scientists will work together with experts from ESA and elsewhere on issues related to radiation environment and effects. Also includes Geant4
- University of Cologne: Development of software for simulation of Non-Ionising Energy Loss (NIEL)
- SpaceGRID, WP on Geant4 MC simulations

Geant4 Promotion

- XMM Radiation Environment Workshop at Vilspa, Spain, November-December 2000
- ISO Calibration Workshop at Vilspa, Spain, February 2001.
- Spacecraft Charging Technology Conference at ESTEC, The Netherlands, April 2001
- Round Table on the 21st Century Monte Carlo Methods for Space Applications at ESTEC, The Netherlands, June 2001
- Eurosim 2001 at TU Delft, The Netherlands, June 2001
- 2001 IEEE Nuclear and Space Radiation Effects Conference (NSREC) in Vancouver, Canada, July 2001

INTEGRAL

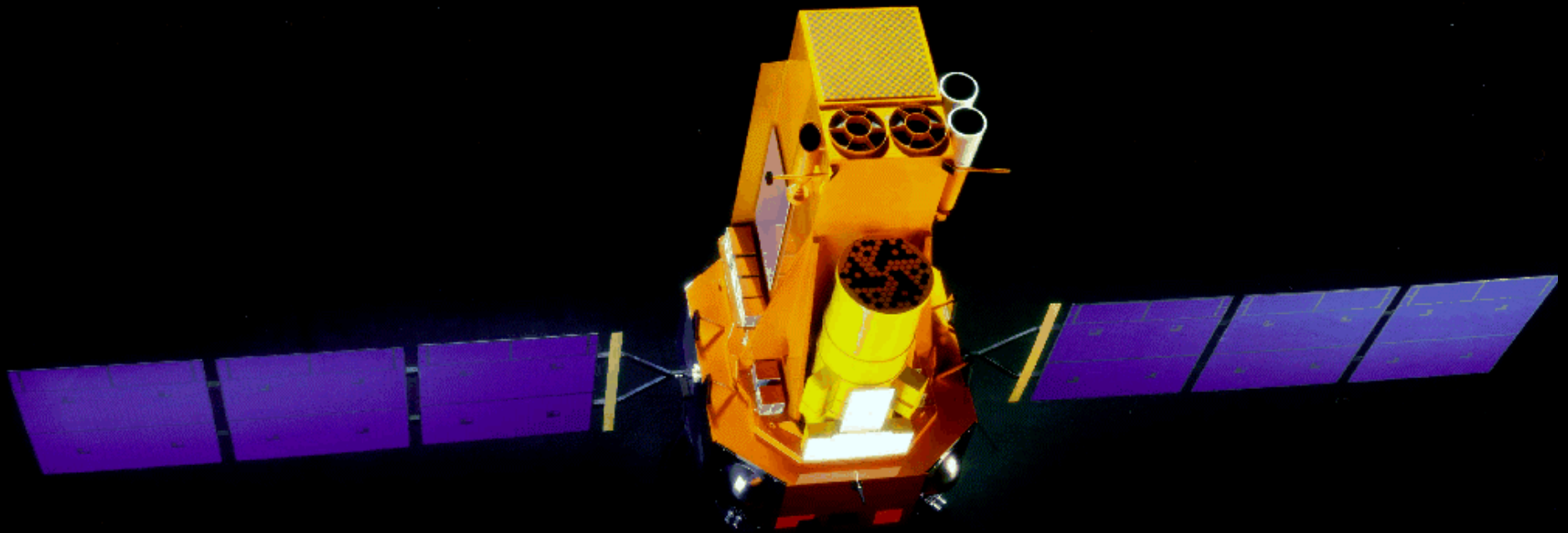

OMI - A shielding problem

- 5-year mission
- Polar orbit
- CCD detector
- Radiation environment **NIEL**
- 40 – 70mm shield
- Al, other?
- SPENVIS **OK** with protons
- Secondary particles problem?

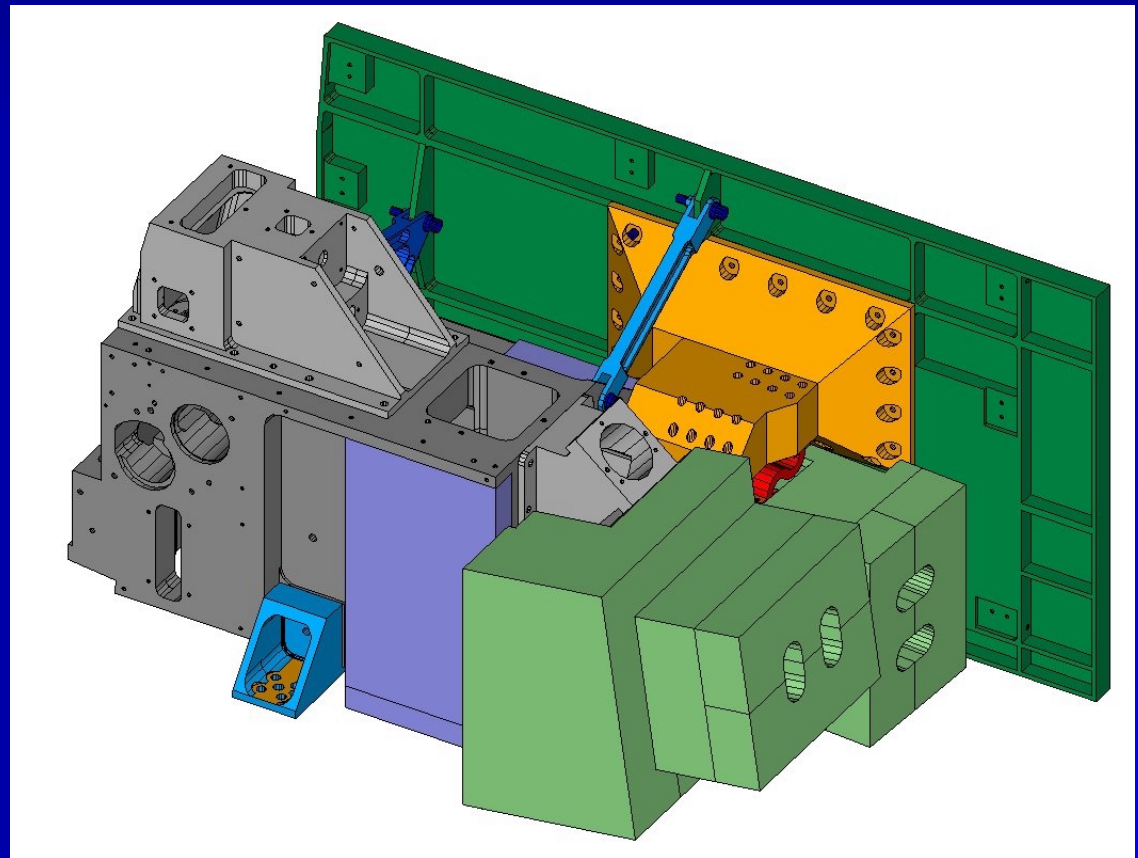

OMI

- Spherical geometry
- Si disk
- 50mm thick Al sphere
- Proton spectrum from SPENVIS
- Isotropic proton distribution using GPS

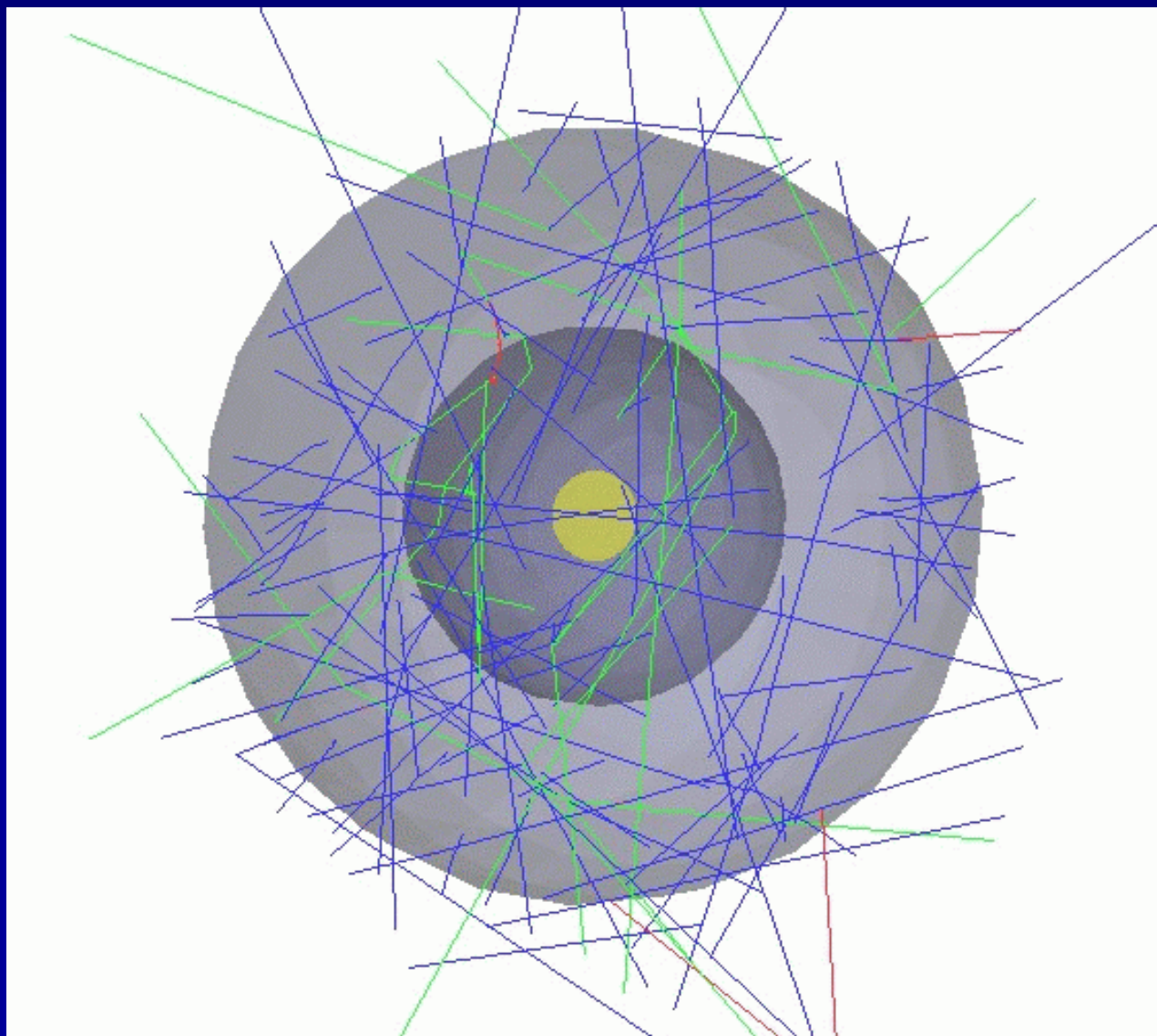

XMM-Newton

- Launched in December 1999, highly elliptical orbit through radiation belts
- Similar design and orbit to Chandra, launched in July 1999
- Study prompted by severe degradation of Chandra's CCDs
- Cause of degradation low-energy protons

XMM-Newton - Geant4 geometry

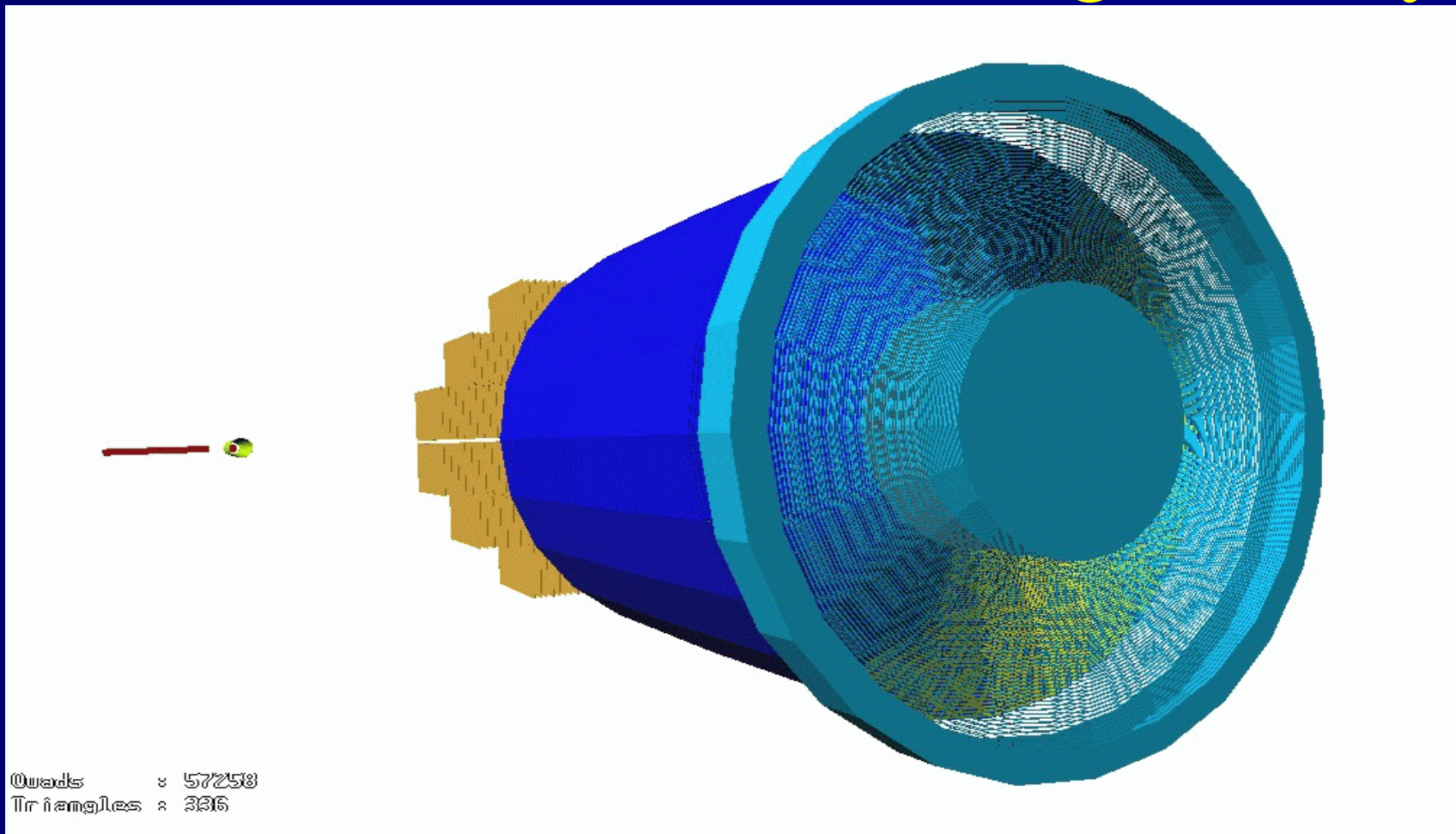

Simulation output

Full trajectory of particles that reach the detector including:

- Type of particle
- Initial energy and position
- Energy and position at all scattering points
- Final energy and position