

Determination of the photon mass attenuation coefficients

Geometrical set-up

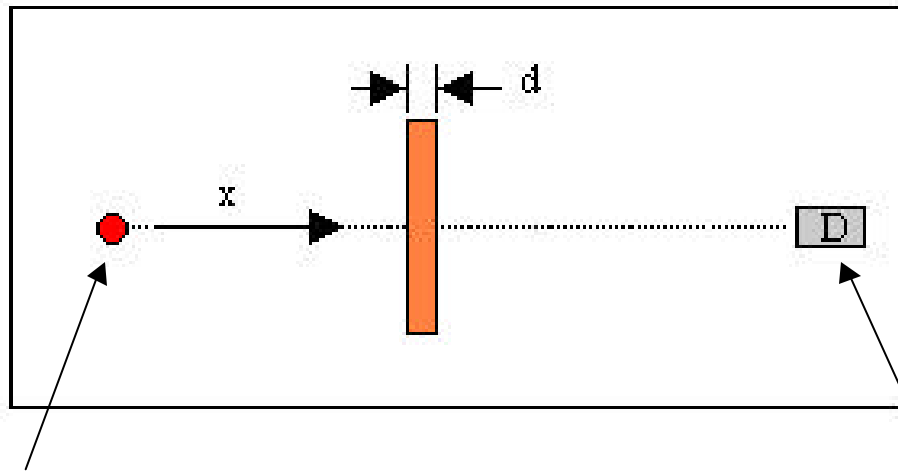

N_0
primary photons generated

N_d
primary photons detected

“Vacuum” material
(checked)
surrounds
the experimental set-up

Check on

- ParentID()
- Energy value

$$N_d = N_0 e^{-\mu \cdot d}$$

$$\frac{\mu}{\rho} = \ln \left(\frac{N_d}{N_0} \right) \frac{1}{\rho}$$

E.M processes implemented

- **E.M. Standard**

- G4PhotoElectricEffect
- G4ComptonScattering
- G4GammaConversion

- **Low Energy**

- G4LowEnergyRayleigh
- G4LowEnergyPhotoElectric
- G4LowEnergyCompton
- G4LowEnergyGammaConversion

Simulation in water, iron, lead
with

E.M.Standard and **LowE extension**

and comparison with the

National Institute for Standard and Technology

(NIST) data

Photon mass attenuation coefficient, Water

LowE

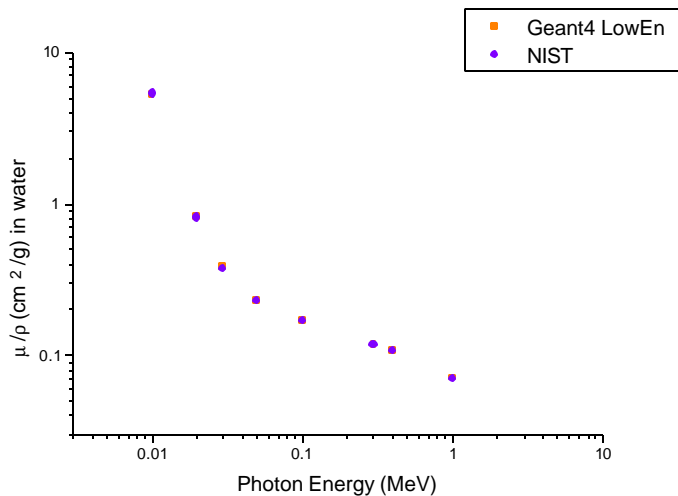

E.M. Standard

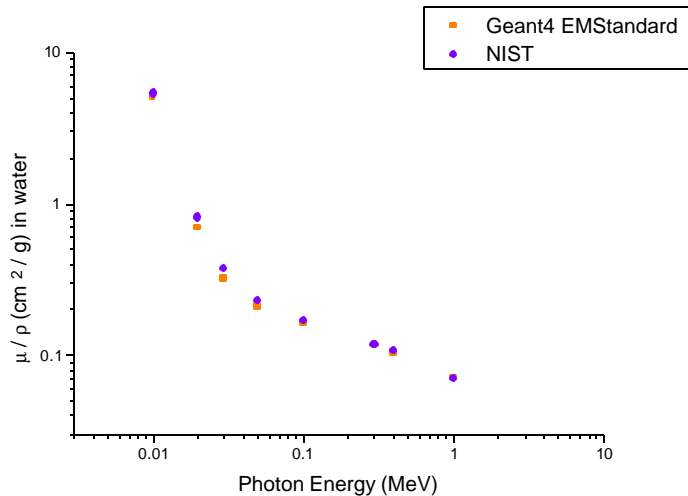

Differences %

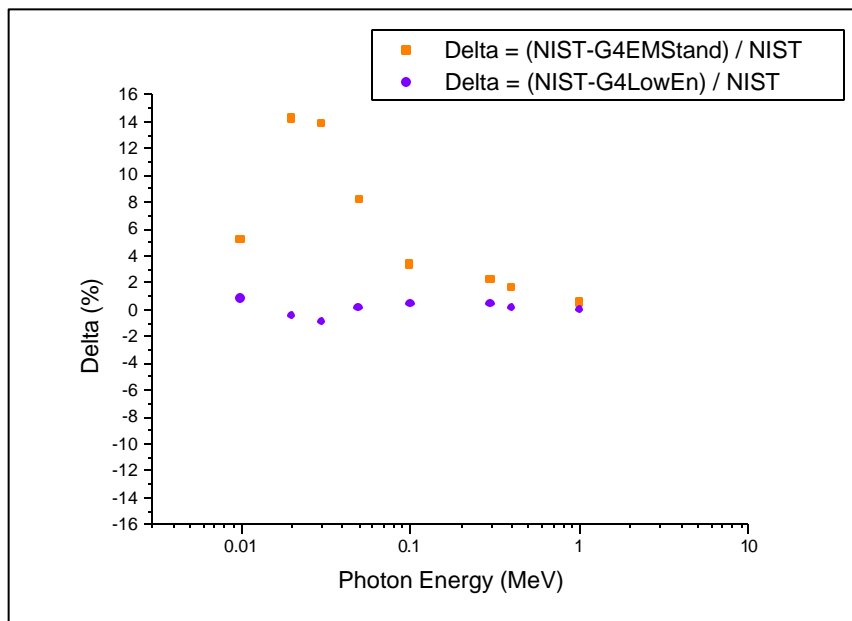

Photon mass attenuation coefficient, Iron

LowE

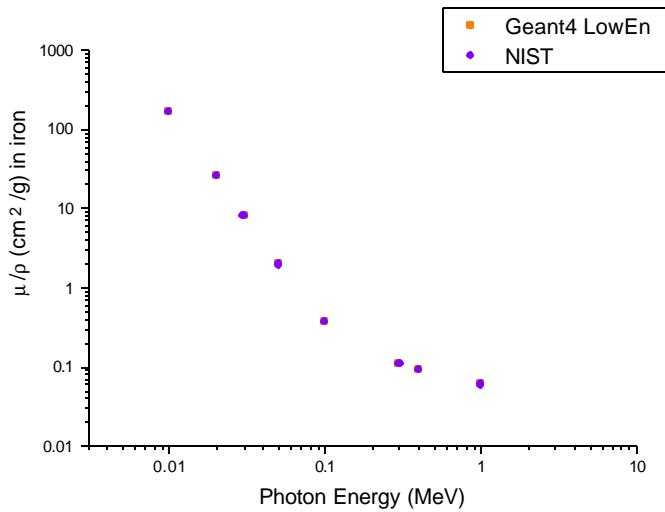

E.M. Standard

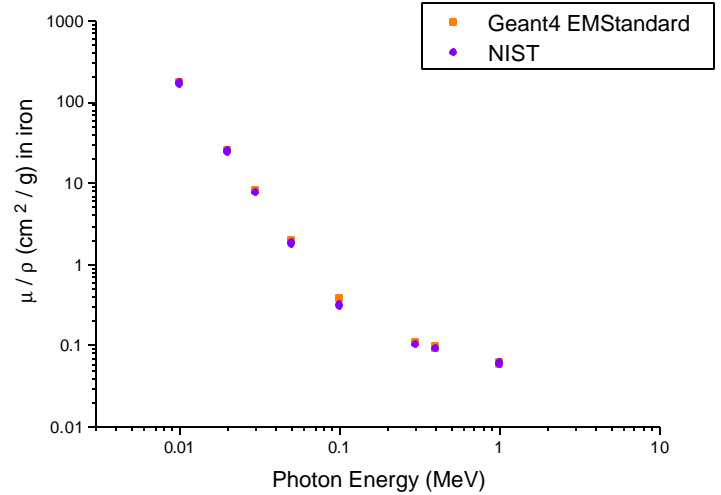

Differences %

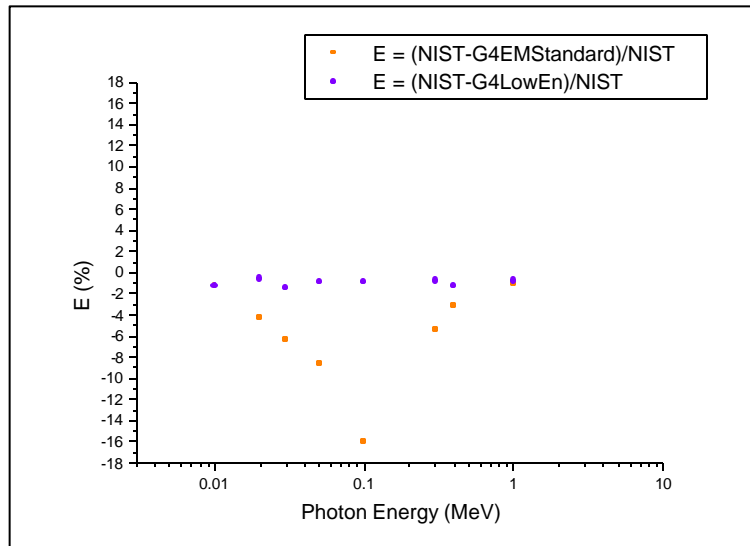

Photon mass attenuation coefficient, Lead

LowE

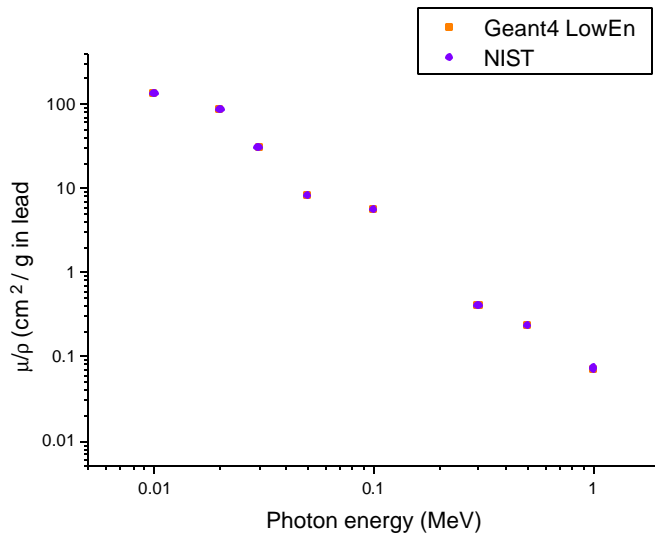

E.M. Standard

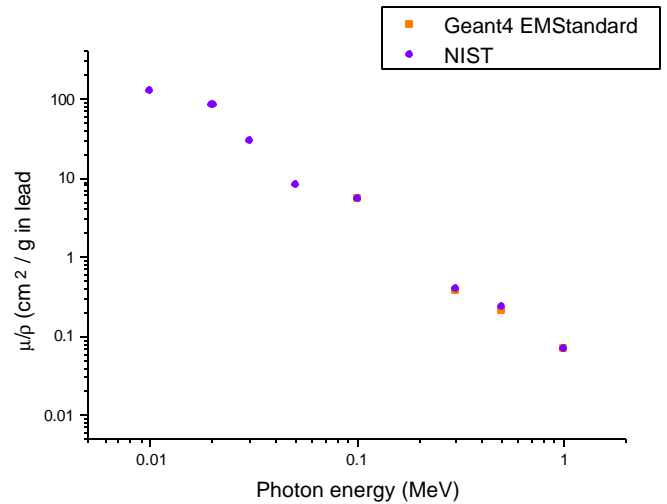

Below 100 KeV zero photons are detected,
all the photons have interaction

Differences %

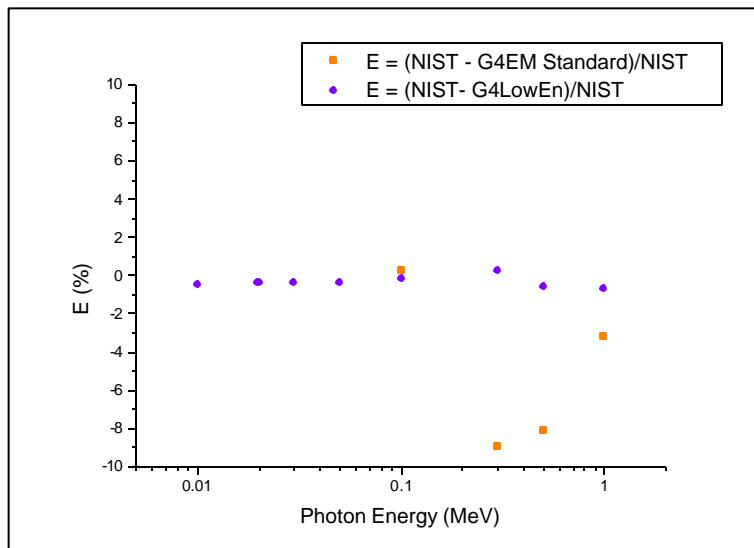

Determination of the **isodose** distribution in water around a ^{192}Ir source

The microSelectron HDR ^{192}Ir source

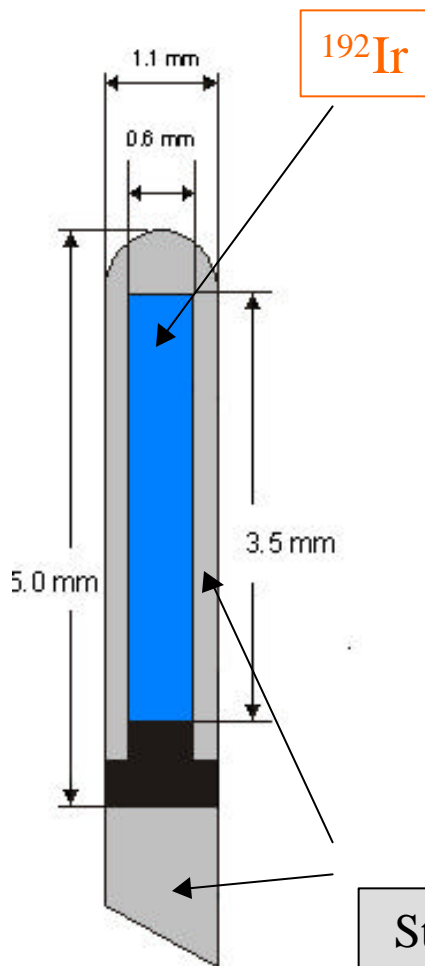

Photon (gamma + x ray) spectrum
of Iridium is complex:
~ **24 lines** in the energy range **9 -885 KeV**



Our **Primary Generator**
(simplified monochromatic model)

G4ParticleGun shoots **gamma**

- random position inside the iridium core
- random direction
- mean energy $\langle E \rangle = 356 \text{ KeV}$

Stainless steel
capsule and cable

Geometrical set-up

The source is placed inside a 30 cm water box which is associated with a **Sensitive Detector** object

We wish to determine the energy deposition in water around the source in a longitudinal plane (cylindrical symmetry)

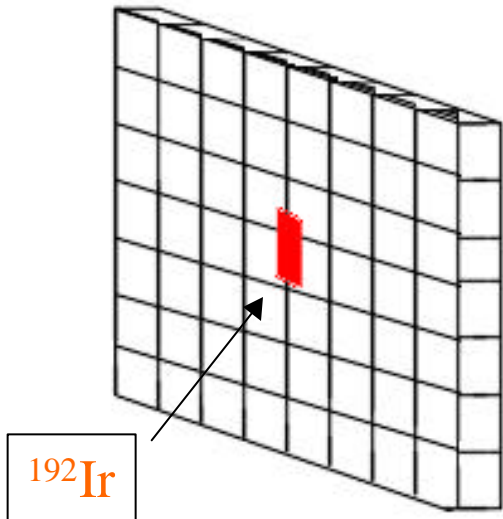

Readout Geometry

The longitudinal plane is portioned in $300 \cdot 300, 1 \text{ mm}^3$, voxels

At every **interaction**, energy deposition is scored and stored in the relevant voxel (in a matrix)

EM Processes implemented

- G4MultipleScattering

gamma

- G4LowEnergyRayleigh
- G4LowEnergyPhotoElectric
- G4LowEnergyCompton
- G4LowEnergyGammaConversion

e-

- G4LowEnergyIonisation
- G4LowEnergyBremsstrahlung

e+

- G4eIonisation
- G4eBremsstrahlung
- G4eplusAnnihilation

Output

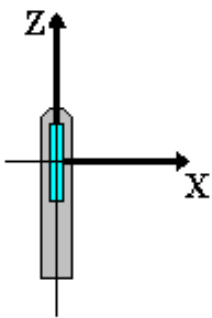

As in the advanced
Brachytherapy example,
at the end of the RUN
an ASCII file is produced
for further processing
with X,Z **energy deposition**

Isodose distribution in water around a ^{192}Ir source

- 20×10^6 photons generated
- ~ 24 hours of simulation

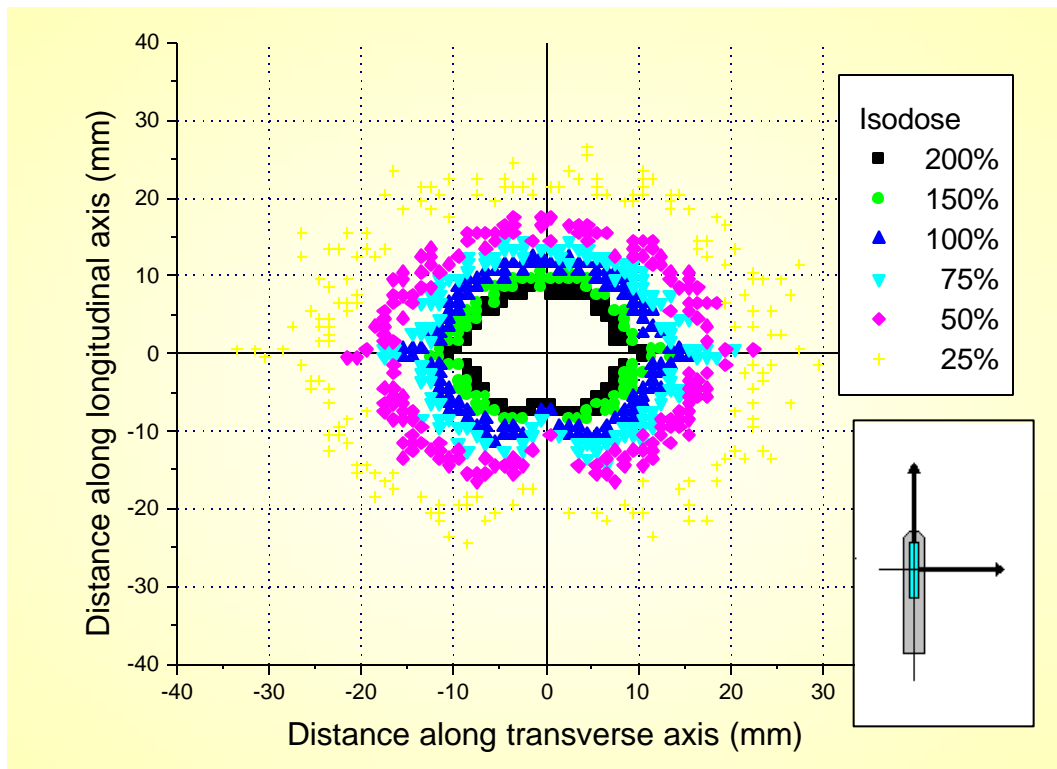

The dose deposition is not isotropic due to

- source geometry
- auto-absorption,
- encapsulation and shielding effects

At the bottom centre of the source we can see the effect of the stainless steel cable

Comparison with isodoses of the *Plato* treatment planning system

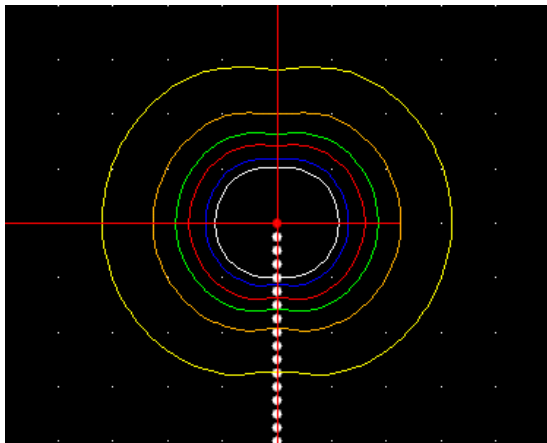

↔
1 cm

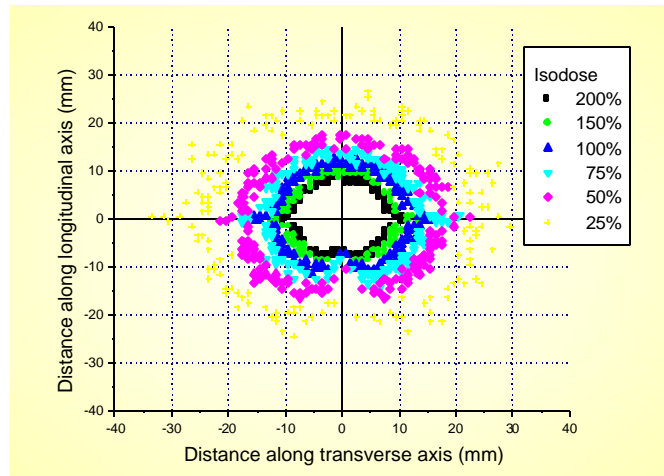

Plato uses an analytical method to calculate the dose distribution:

- Point approximation of the source to compute the dose
- Anisotropy function $F(\varphi)$, instead of $F(r, \varphi)$ as it should be, to account for the shielding effect of the capsule, etc..

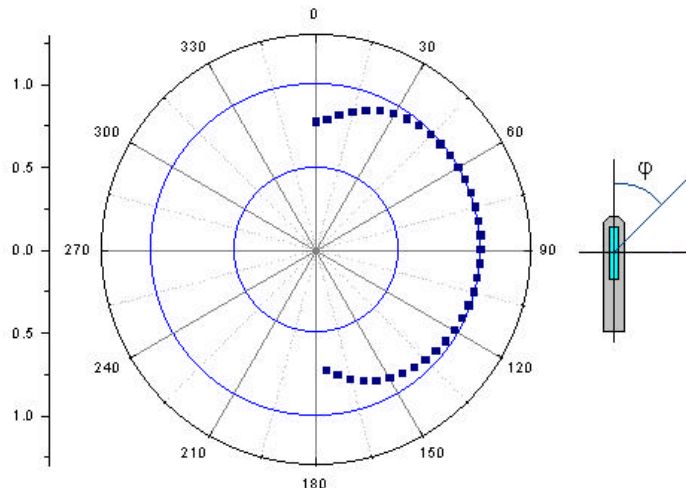

Comparison with the isodoses of the *Plato* treatment planning system

Transverse axis

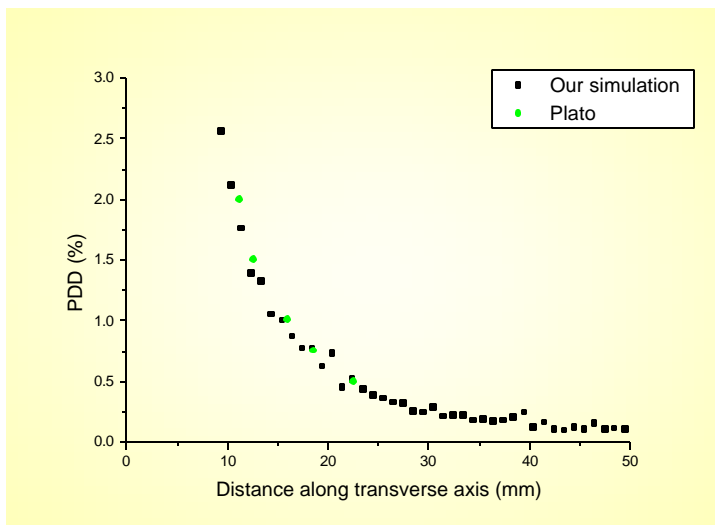
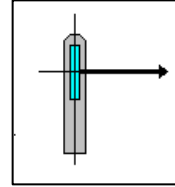

- Good agreement

Longitudinal axis

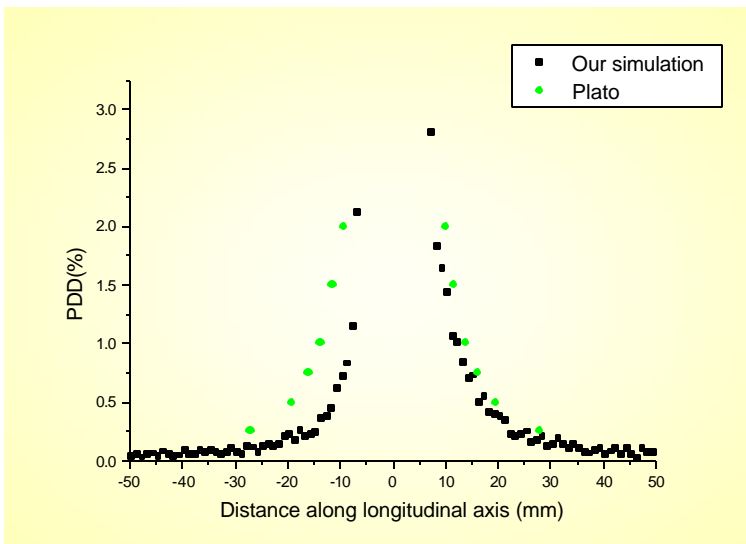
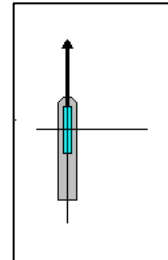

- Good agreement in front of the source
- Less good agreement behind the source

The disagreement in the region behind the source is due to the approximation introduced by the anisotropy function in this direction

Geant4 yields a more realistic behaviour

Initial results for the Leipzig applicator



The **Leipzig** applicators were designed to give the optimum **isodoses** and treat to the correct depth

This applicator has the shape of a hollow cylinder of **tungsten** containing the source

Geometrical set-up

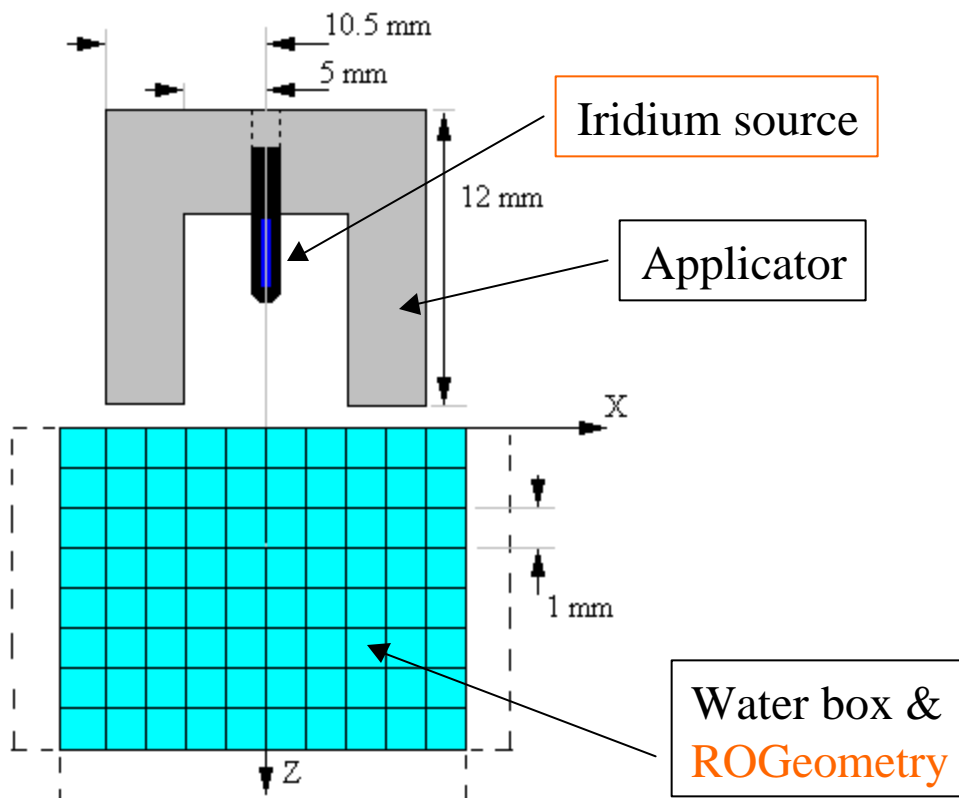

Isodose distribution in water for the **Leipzig applicator**

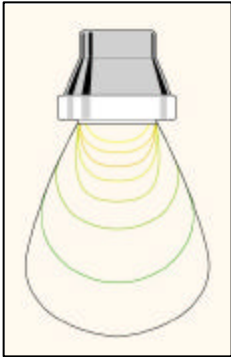

- 10^8 photons generated
- ~ 4 days of CPU time

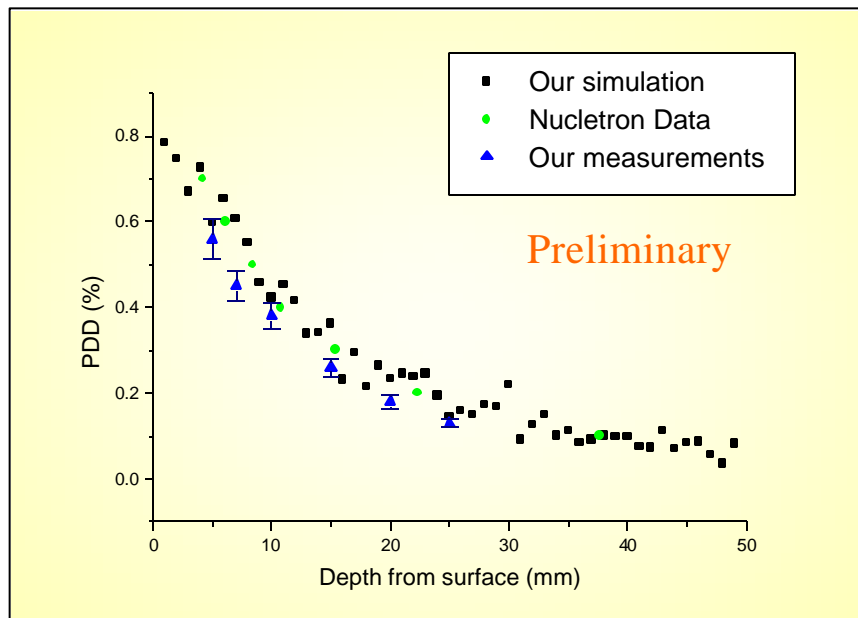
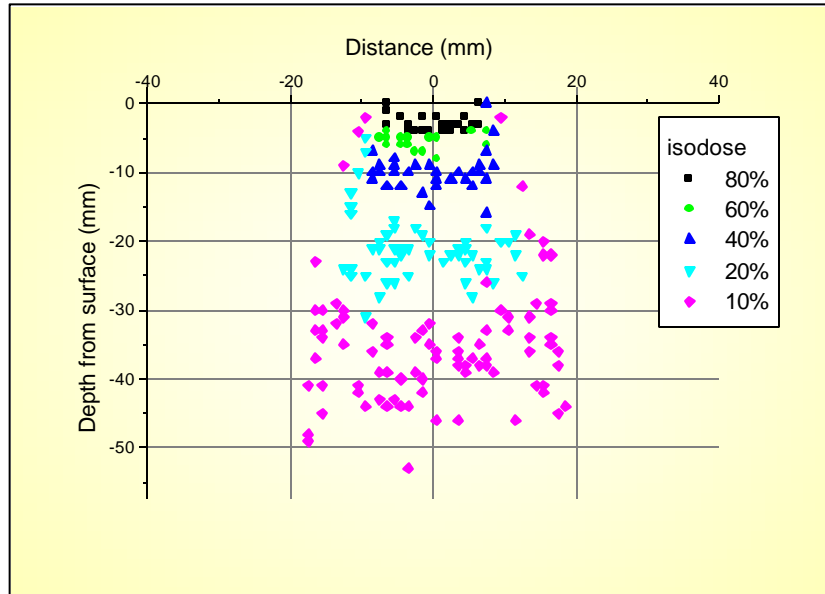

These are the initial results with this kind of **applicator**

- good agreement with manufacturer's data (Nucletron)
- satisfactory agreement with our measurements
(we have just started making measurements and the systematic errors for the response of the detector are not well known yet)

Conclusion

Our activities at 

- Porting on **Windows 98+Cygwin+VisualC++** environment
- Simple test for the EM processes
- Application in the **medical field**
Simulation for **isodose** distribution and comparison of the result with those of our TPS and measure
- Promotion of Geant4 with poster and oral presentation in several **medical physics** congress (AIFM, ESTRO, AIRO, ...)



We think that **Geant4** is an **useful** instrument in medical radiation physics

Its use out of the **HEP community** could be advantageous both for users (as we are) and for the code developers