

A Forward Photon Tagging Facility for CLAS12

M.Battaglieri
*Istituto Nazionale di Fisica Nucleare
Genova - Italy*

CLAS12 EUROPEAN WORKSHOP

25-28 February 2009
Genova, Italia

First European Workshop
on the physics program and
equipment of the CLAS12
experiment at Jefferson Lab

Location:
Dipartimento di Fisica dell'Università di Genova
Via Dodecaneso 33, 16146 Genova, Italia

Information:
<http://www.ge.infn.it/~clas12>
clas12@ge.infn.it





From CEBAF at 6 GeV

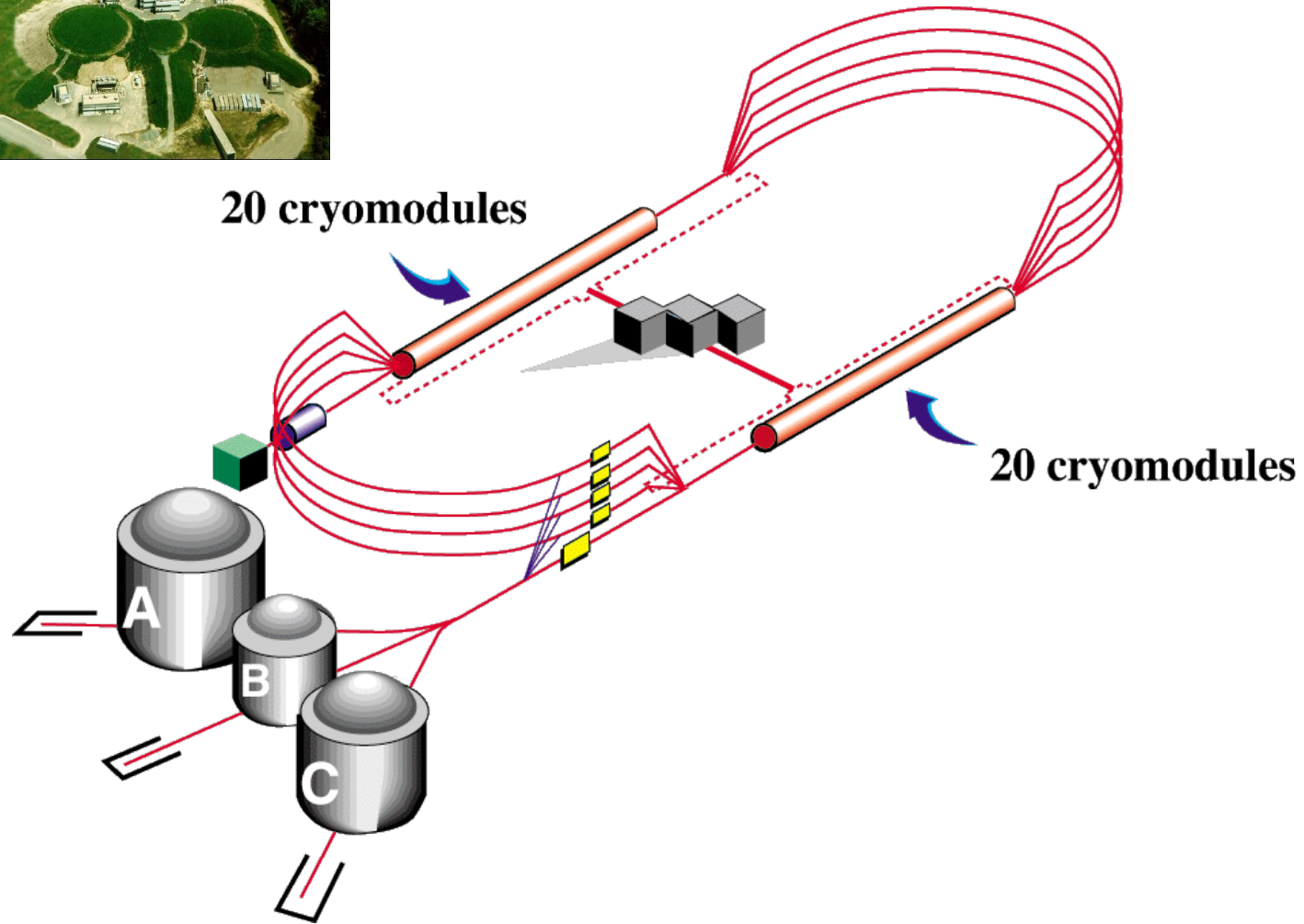



From CEBAF at 6 GeV to CEBAF at 12 GeV

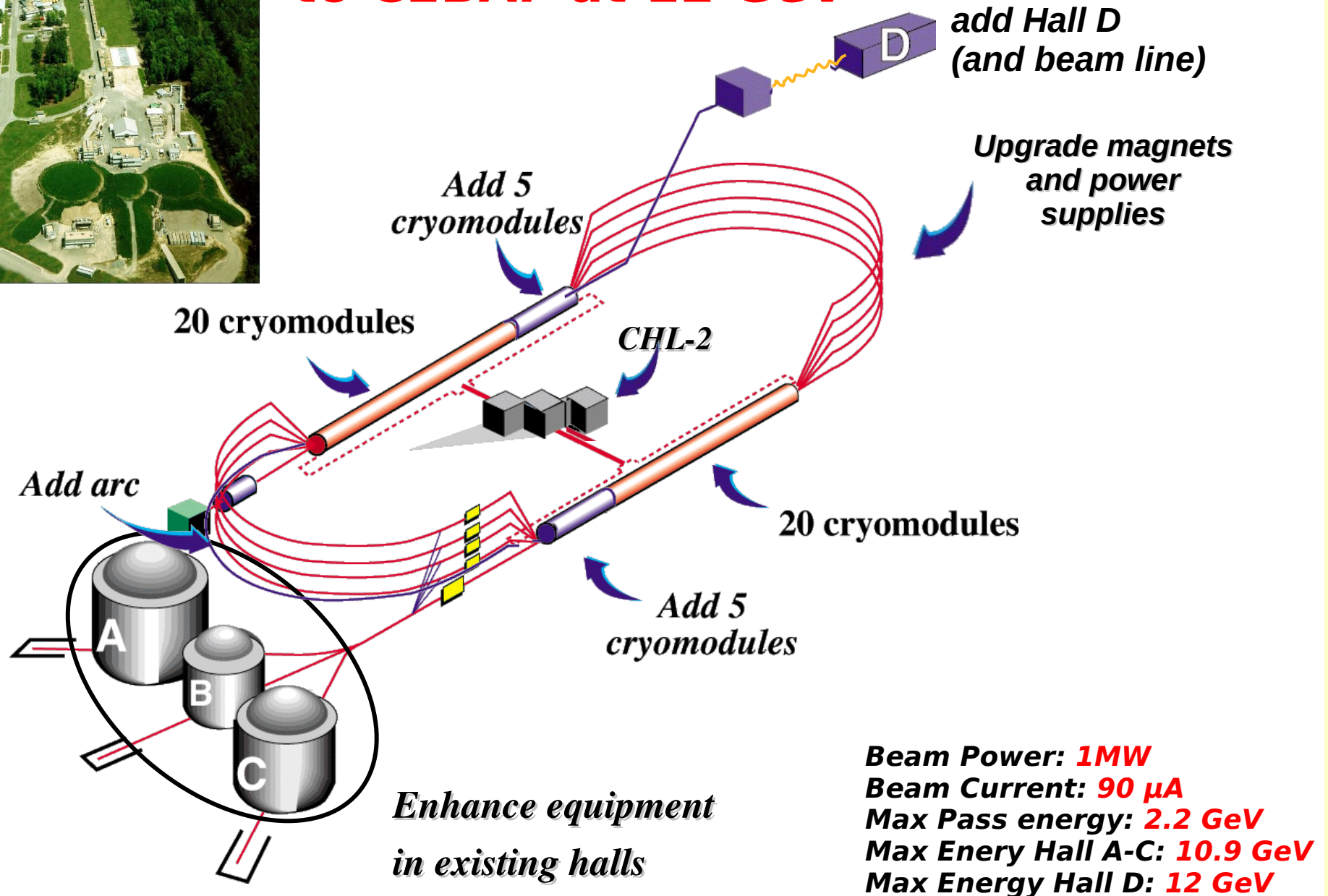

The Hall-B photon tagger

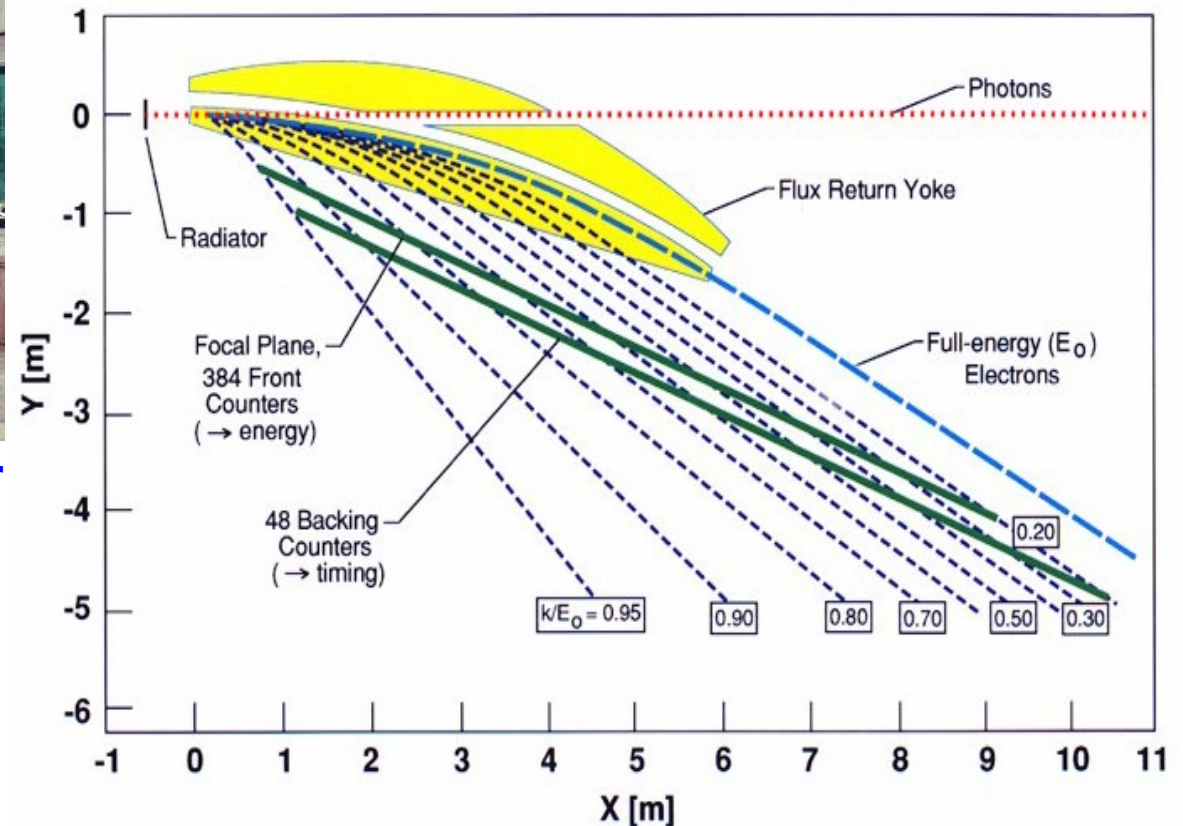

- Gold and diamond radiator for In/Coherent Bremsstrahlung
- Energy coverage: 0.2-0.95 E_0
- Efficiency $\sim 80\%$
- Energy Resolution $\sim 10^{-3}$
- Timing Resolution ~ 100 ps

The existing dipole magnet is unable to deflect the 11 GeV primary beam on the existing beam-dump

The existing PHOTON TAGGER will be available for energies up to $E_\gamma \sim 6.1$ GeV

Options for $E_\gamma > 6$ GeV?

Why photoproduction?

Physics motivations

Meson spectroscopy

Standard PWA on H target

Spectroscopy on He4 and other gas targets

Hadron spectroscopy

Heavy mass baryon resonances (Cascades)

double-strangeness sets a higher mass

small width helps to detect and study excited states

Compton scattering

Meson polarizabilities

J/Ψ production close threshold and on nuclear targets

Large $-t$ physics

.....

Why photoproduction?

Physics motivations

Meson spectroscopy

Standard PWA on H target

Spectroscopy on He4 and other gas targets

Hadron spectroscopy

Heavy mass baryon resonances (Cascades)

double-strangeness sets a higher mass

small width helps to detect and study excited states

Compton scattering

Meson polarizabilities

J/Ψ production close threshold and on nuclear targets

Large $-t$ physics

.....

Meson spectroscopy with photons at JLab

Why photoproduction?

★ Photoproduction: exotic J^{PC} are more likely produced by $S=1$ probe

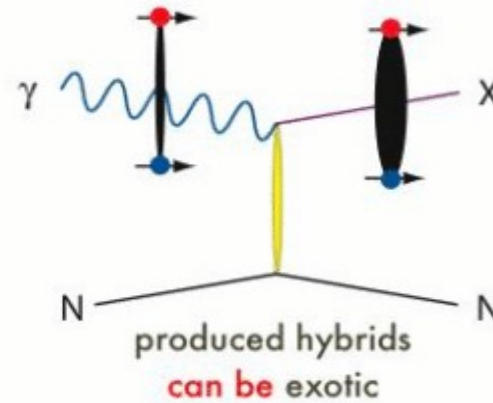
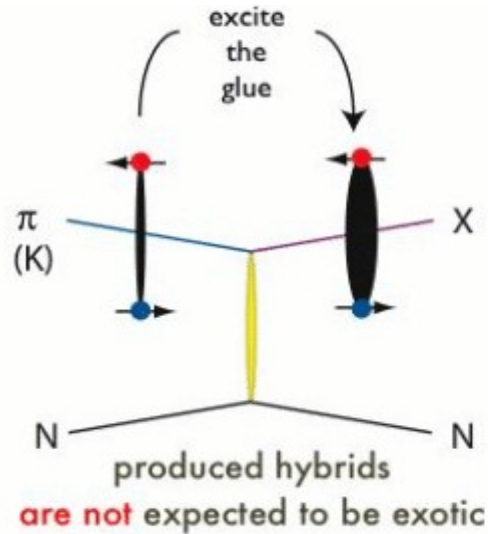

★ Production rate for exotics is expected comparable as for regular mesons



Few data (so far) but expected similar production rate as regular mesons

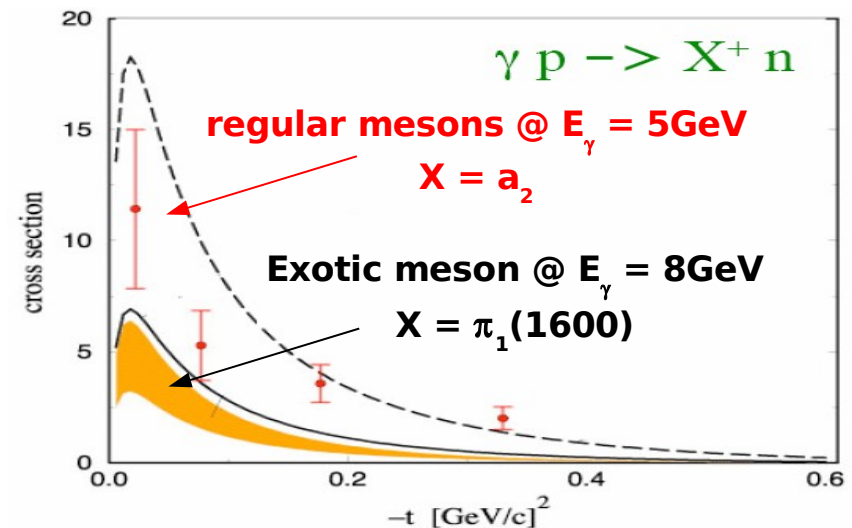

Partial Wave Analysis

1) the isobar model e.g. 3π system

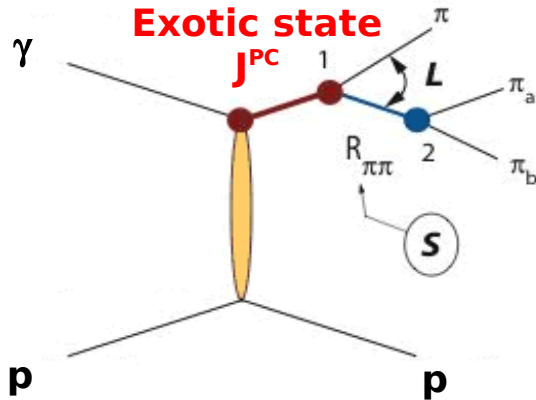

(a) resonance: X decay
 $X(2^{++}) \rightarrow f_2(1275)\pi$

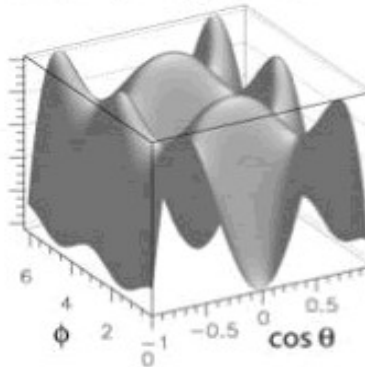

(b) isobar: $R_{\pi\pi}$ decay
 $f_2(1275) \rightarrow \pi\pi$

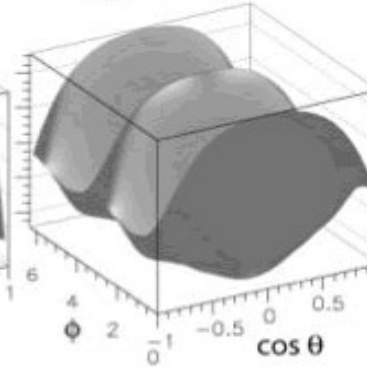

Does the PWA work with photo-production data?
Use the PWA machinery on CLAS data

2) Moments+Dispersion relations e.g. 2π system

1) Moments of the angular distribution in term of partial waves

$$\langle Y_{\lambda\mu} \rangle(E_\gamma, t, M) = \frac{1}{\sqrt{4\pi}} \int d\Omega_\pi \frac{d\sigma}{dt dM d\Omega_\pi} Y_{\lambda\mu}(\Omega_\pi)$$

$$\langle Y_{00} \rangle = N [|S|^2 + |P_-|^2 + |P_0|^2 + |P_+|^2 + |D_-|^2 + |D_0|^2 + |D_+|^2 + |F_-|^2 + |F_0|^2 + |F_+|^2]$$

2) Parametrize partial waves in term of known $\pi\pi$ phase shift and unknown coefficients using Dispersion Relations

3) Derive partial wave cross sections to compare with models

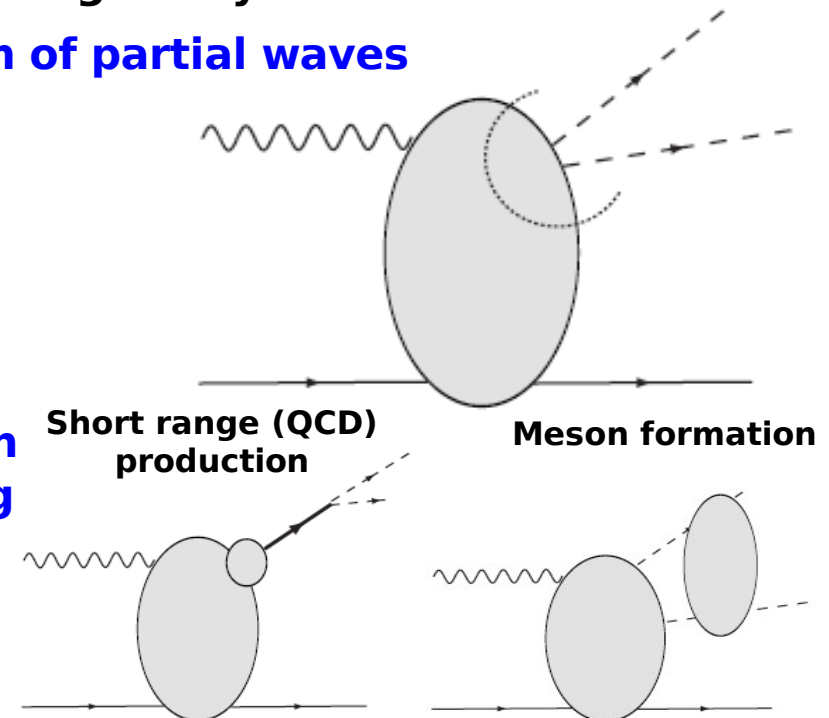

Partial Wave Analysis with CLAS

Isobar Model

$$\gamma p \rightarrow (n) \pi^+ \pi^+ \pi^-$$

★ Possible evidence of exotic meson $\pi_1(1600)$ in $\pi^- p \rightarrow p \pi^- \pi^- \pi^+$ (E852-Brookhaven)

★ Not confirmed in a re-analysis of a higher statistic sample

Simple final state with low background

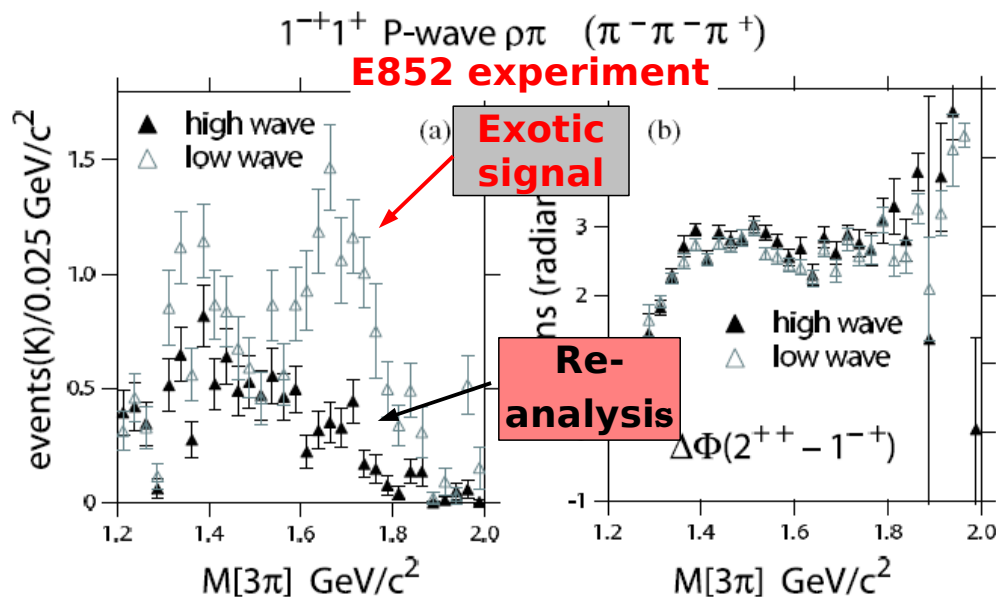

CLAS/g6c (preliminary)

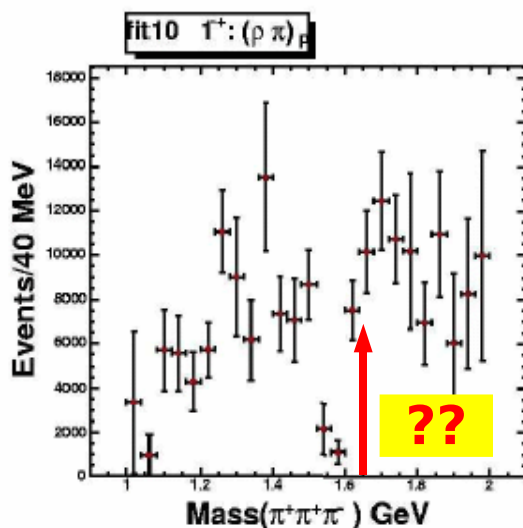
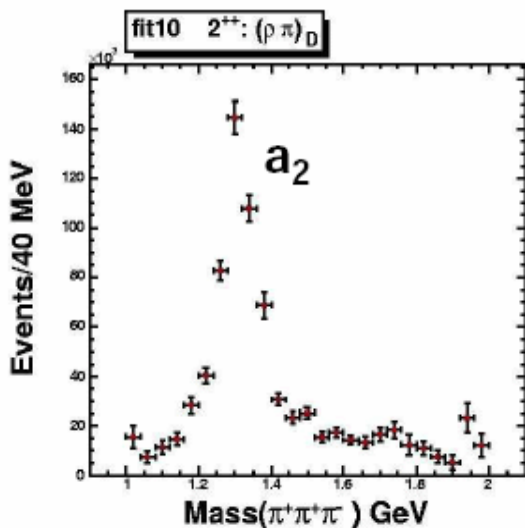

★ Clear evidence of non-exotic 2^{++} state $a_2(1320)$

No-evidence of exotic 1^+ state $\pi_1(1600)$

★ Relevance of baryon resonance background

PWA in CLAS is feasible!

Partial Wave Analysis with CLAS

Moments + Dispersion relations



$M(\pi^+\pi^-)$ spectrum below 1.5 GeV

P-wave: ρ meson

D-wave: $f_2(1270)$

S-wave: σ , $f_0(980)$ and $f_0(1320)$

Fitted moments

$3.4 \text{ GeV} < E_\gamma < 3.6 \text{ GeV}$

$0.5 \text{ GeV}^2 < -t < 0.6 \text{ GeV}^2$

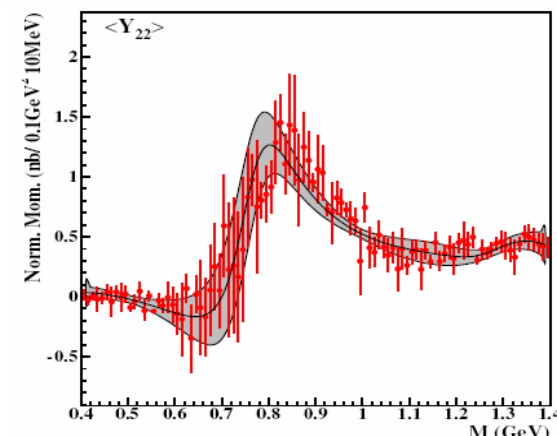
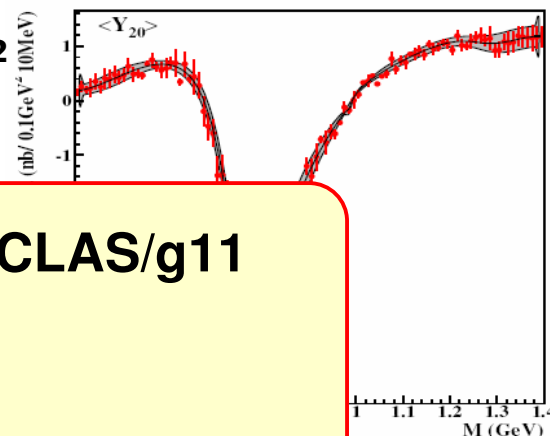
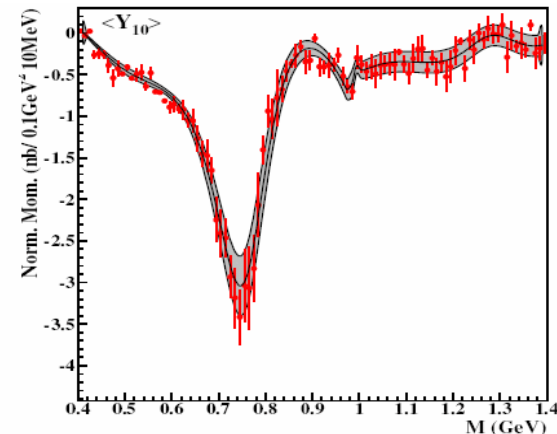
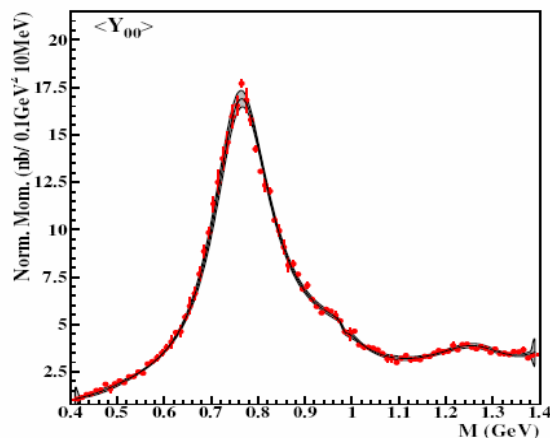

CLAS/g11

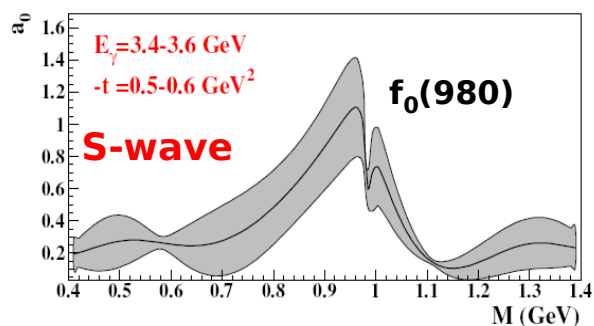
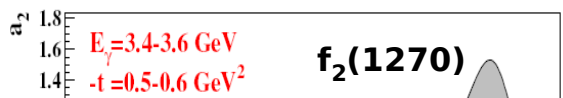
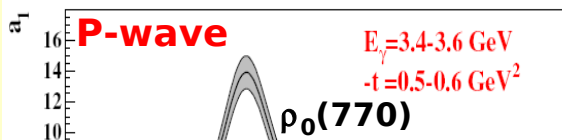

**PWA in CLAS
is feasible!**

★ Known states are well reproduced, e.g. $\rho(770)$

★ First observation of direct production of $f_0(980)$ ($\pi\pi$ S-wave) meson

Accepted by Phys.Rev.Lett. 2009

Photoproduction experiments at JLab-12

★ The Detectors

- Determination of J^{PC} of meson states requires **Partial Wave Analysis**
- Decay and Production of **exclusive** reactions
- Good acceptance, energy resolution, particle Id



Hermetic charged/neutral particles detector

Hall-D - GlueX Detector

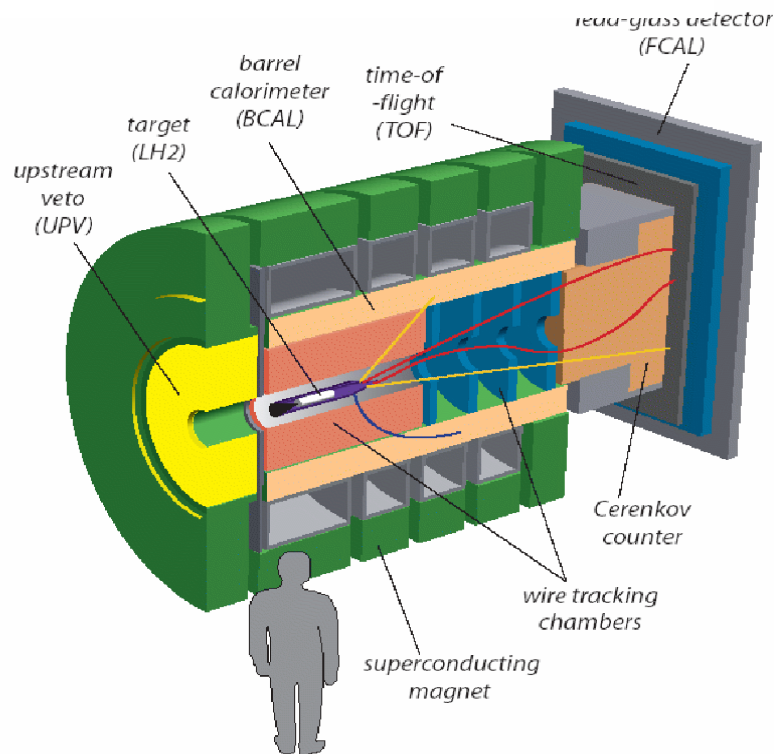

Hall-B - CLAS12 Detector

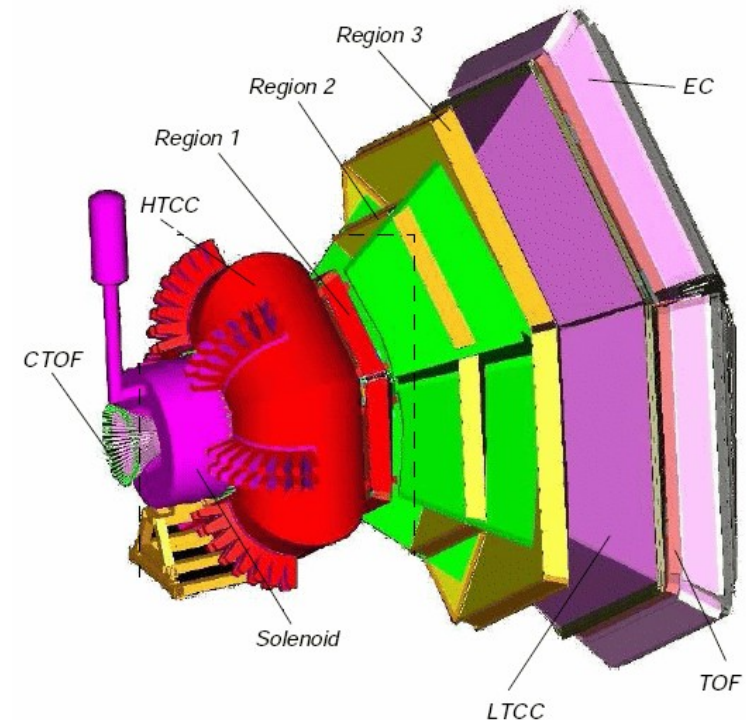

Photoproduction experiments at JLab-12GeV

★ The photon beam

- With a 11-12 GeV electron beam only few choices:
 - 1) Bremsstrahlung
 - 2) Quasi-real electro-production
- **Tagger** (initial photon energy) is required to add 'production' information to decay
- **Linear polarization** is useful to simplify the PWA and essential to isolate the nature of the t-channel exchange

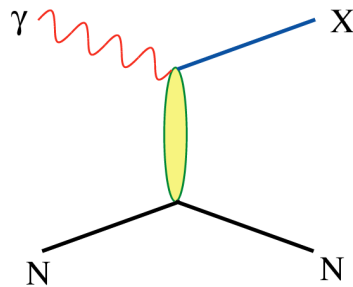

- ★ Essential to isolate production mechanisms (M)
- ★ Polarization acts as a J^{PC} filter if M is known
- ★ Linear polarization separates natural and unnatural parity exchange

Hall-D and Hall-B will host real photon beam!

Meson spectroscopy with photons at JLab-12GeV

Coherent tagged Bremsstrahlung Hall-D

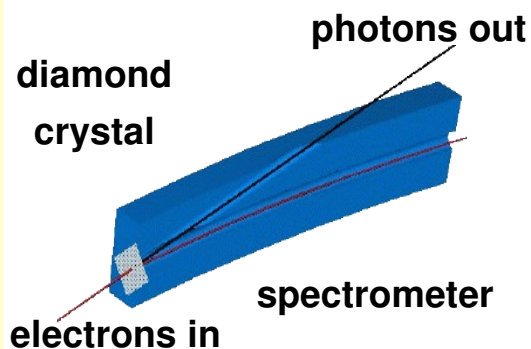

Performance

- ★ $(.5-.95) E_{\text{beam}} \rightarrow 6 < E_{\gamma} < 11 \text{ GeV}$
(10MeV resolution)
- ★ Photon Flux $\sim 10^7 - 10^8 \text{ } \gamma/\text{s}$
- ★ 30cm LH target \rightarrow
 $L \sim 10^{31} \text{ cm}^{-2}\text{s}^{-1}$
- ★ Linear polarization
 $\sim 50\% - 15\%$ (collective)

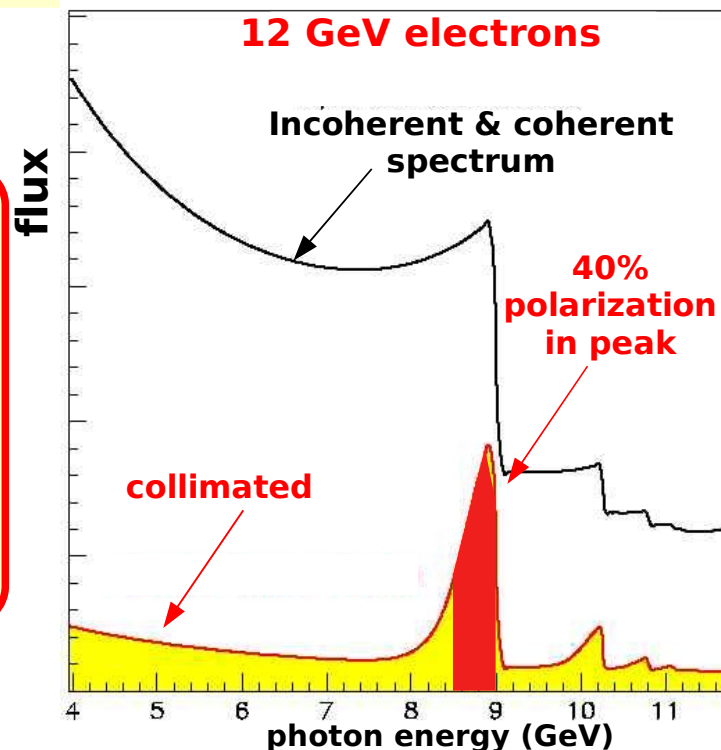

Quasi-real electroproduction at very Low Q^2 Hall-B

$E_{\text{scattered}}$	1 - 4 GeV
θ	$0.5^\circ - 1.2^\circ$
ϕ	$0^\circ - 360^\circ$
ν	7 - 10 GeV
Q^2	0.003 - 0.029 GeV^2
W	3.9 - 4.6 GeV
x_{Bj}	0.0001 - 0.002

Performance

- ★ $7 < E_{\gamma} < 10 \text{ GeV}$
- ★ 5cm LH target $\rightarrow L \sim 10^{34} \text{ cm}^{-2}\text{s}^{-1}$
- ★ Linear polarization $\sim 65\% - 20\%$ (individual)
- ★ Capability of forward tagging (electron detection)

Real and quasi-real photon beams at JLab-12GeV

Coherent tagged Bremsstrahlung: well established technique

↪ Hall-B real Bremsstrahlung Photon Tagger

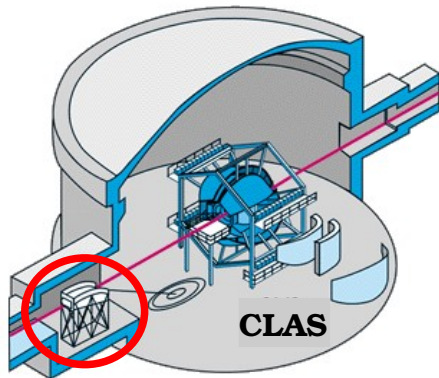

Performance

- ★ $E_\gamma = 0.8 - 5.4 \text{ GeV}$ (20% - 95% E_{beam})
- ★ $\Delta E_\gamma / E_\gamma \sim 10^{-4}$ $t \sim 200 \text{ ps}$
- ★ Linearly polarized photons (coherent Bremsstrahlung)

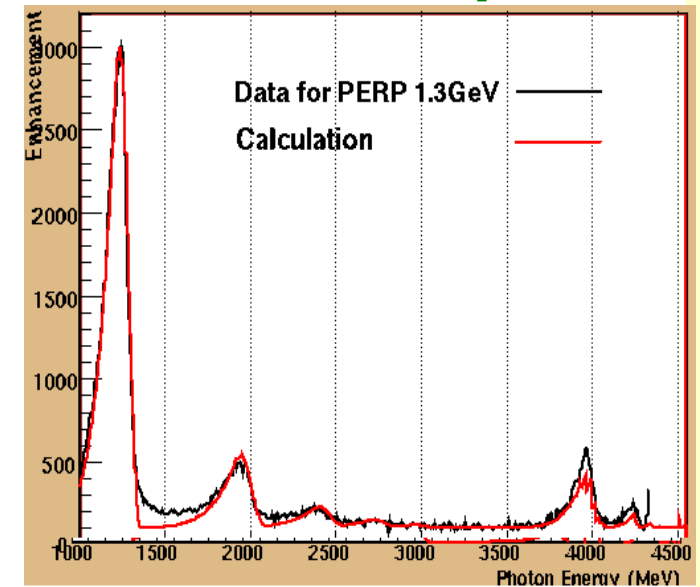

Real and quasi-real photon beams at JLab-12GeV

Coherent tagged Bremsstrahlung: well established technique

Hall-B real Bremsstrahlung Photon Tagger

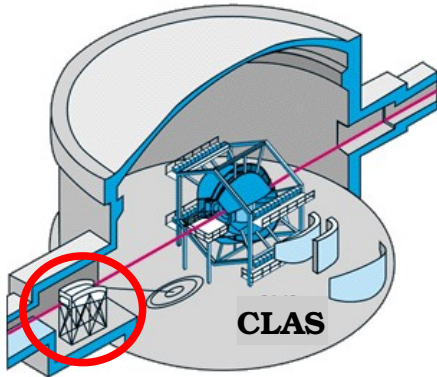

Performance

- ★ $E_\gamma = 0.8 - 5.4 \text{ GeV}$ (20% - 95% E_{beam})
- ★ $\Delta E_\gamma / E_\gamma \sim 10^{-4}$ $t \sim 10^{-10}$ s
- ★ Linearly polarized (coherent Bremsstrahlung)

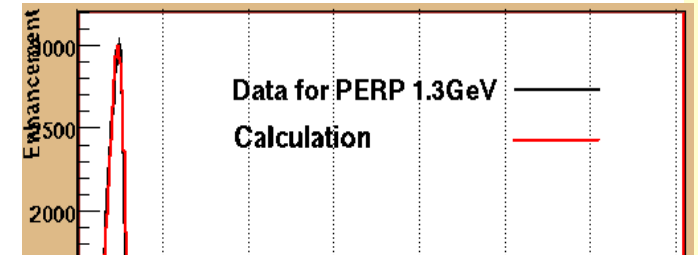

Quasi-real electroproduction at very Low Q^2

- ★ Test level
- ★ Fake " 0^0 " electroproduction (no electron in the trigger) from huge collected statistic

**Bright meson peaks show up
The technique works!**

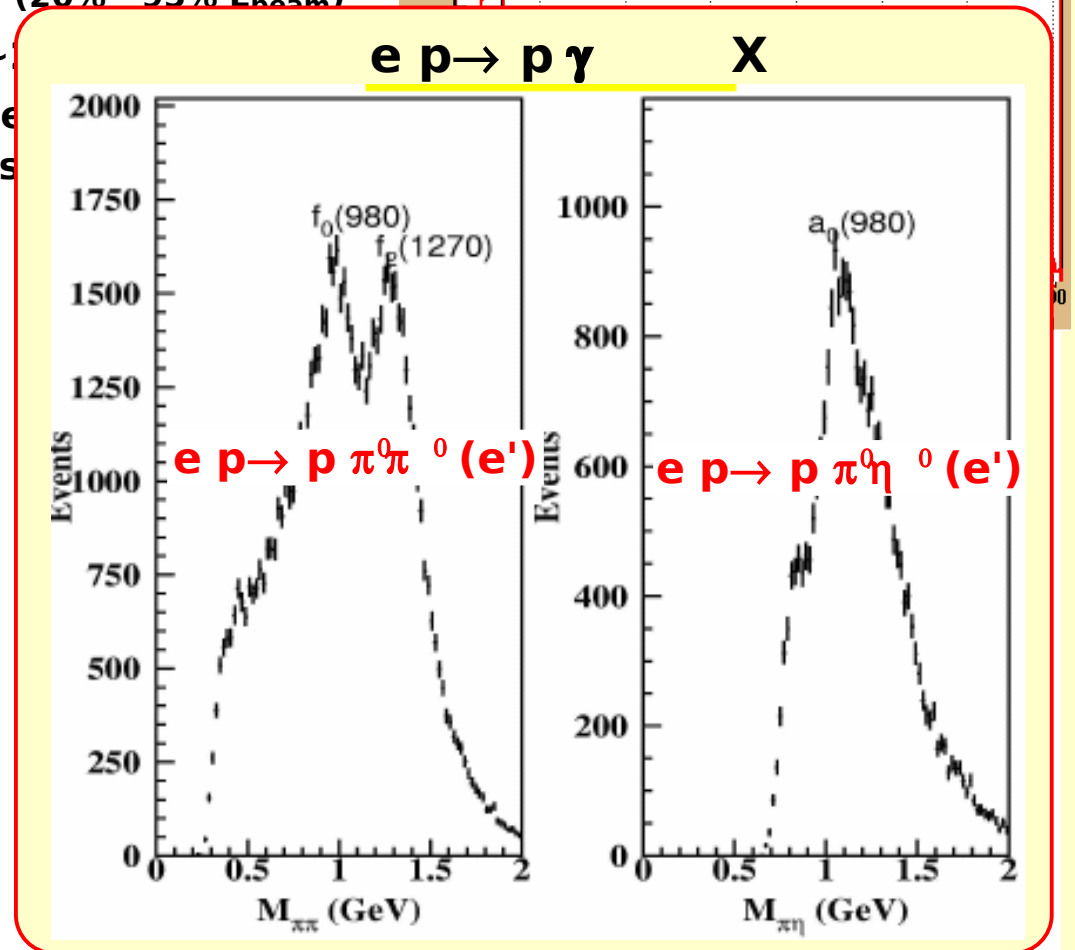

Coherent meson production on nuclei

Eliminate *s*-channel resonance background

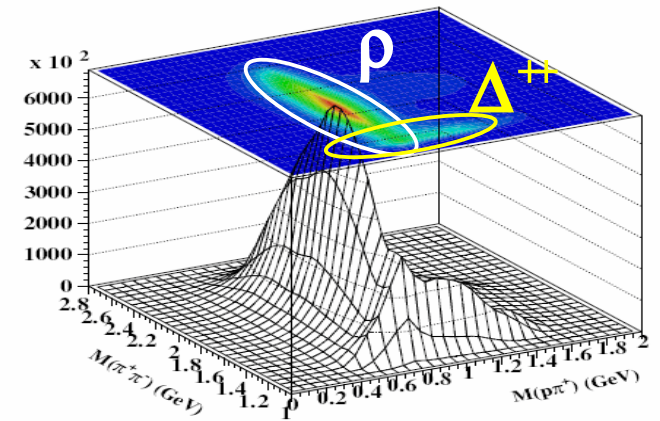
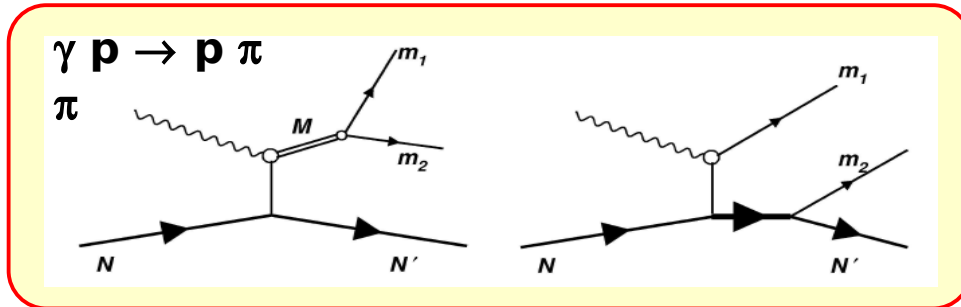

Simplify PWA: $S=I=0$ target acts as spin and parity filter for final state mesons

Production cross section expected $\sim e^{-bt} |A F_A(t)|^2 \rightarrow$ **low -*t* kinematic**

Detection of recoiling nucleus:

- **low -*t*** ($p \sim 0.2-0.5$ GeV)
- **thin (gas) target** ($\sim 10^{-3}$ g/cm²)

Photon beam:

- **small size**
- **high flux**

**quasi-real
photoproduction
Hall-B**

Meson spectroscopy on ⁴He

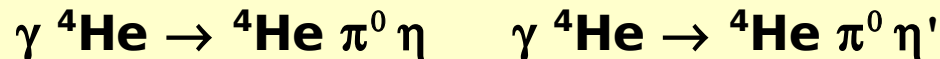

Strongest evidence of $J^{PC}=1^- \pi_1(1400)$ exotic meson

$\pi^- p \rightarrow n \eta \pi^0$ in E852-Brookhaven

Search for a resonance in P-wave in $\pi^0 \eta$ and $\pi^0 \eta'$

Known (non-exotic) resonances can be used as a benchmark (e.g. $J^{PC}=2^{++} a_2(1232)$)

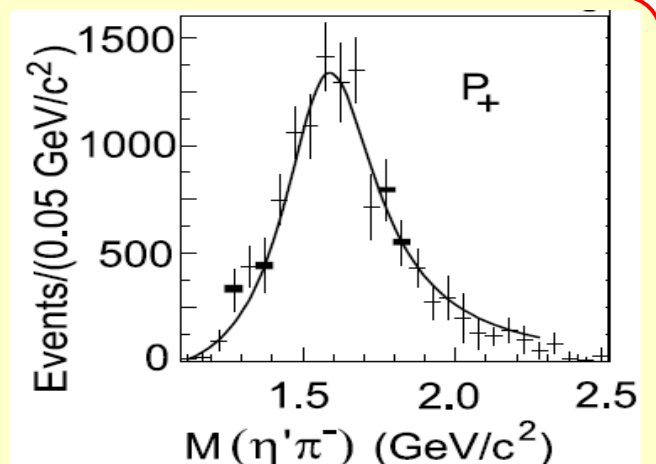

CLAS12 in Hall B

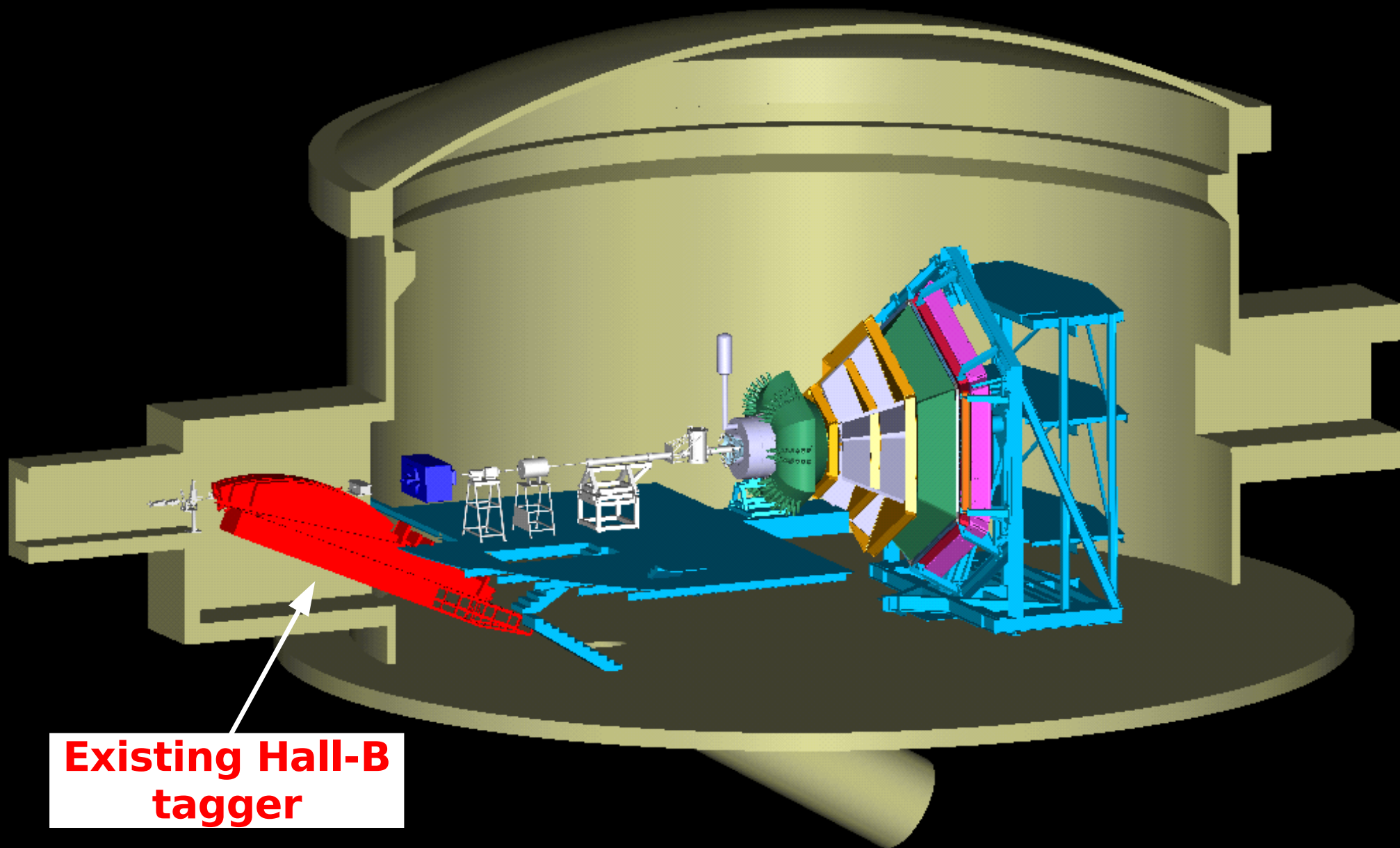

**Existing Hall-B
tagger**

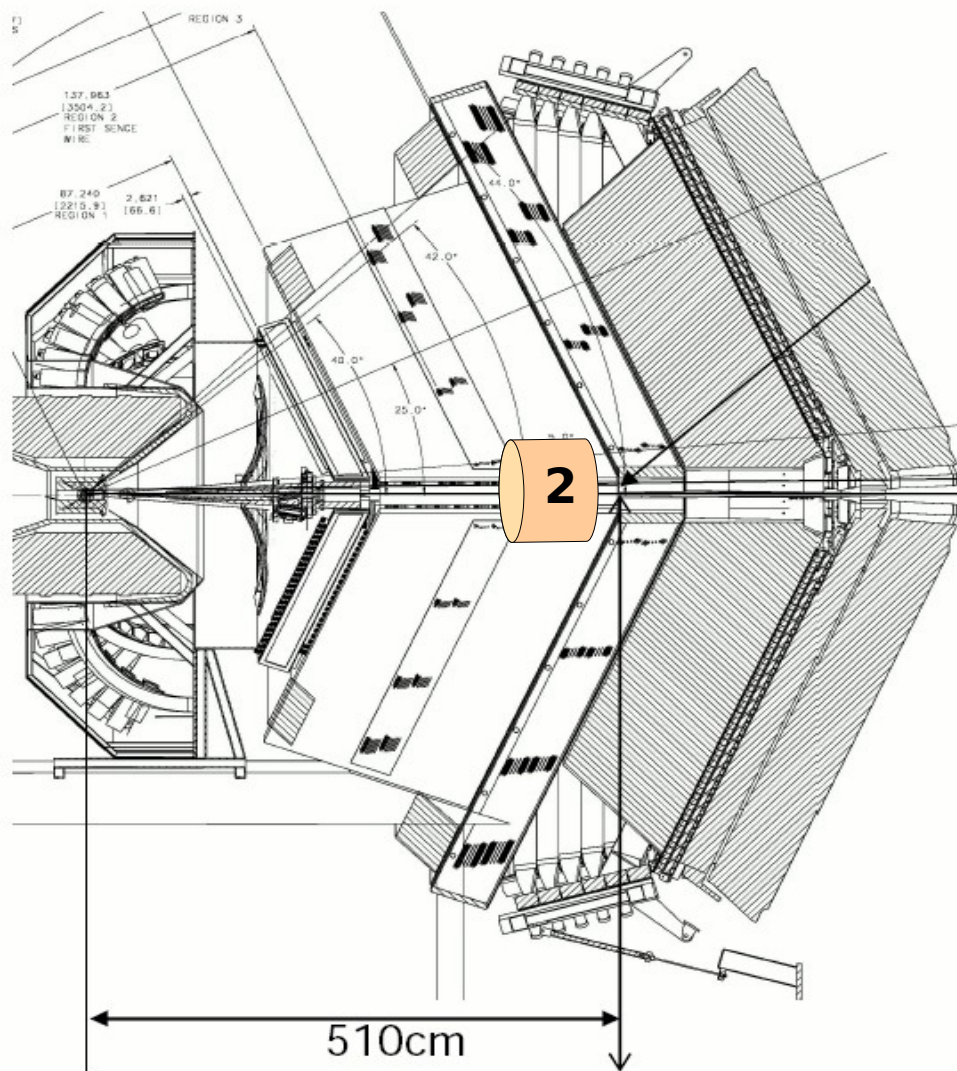

Two possible options for tagger location:

- ★ 1) downstream
- ★ 2) between target and torus support

$\theta_{\max} \sim 0.5^\circ$ **1** Forward tagger

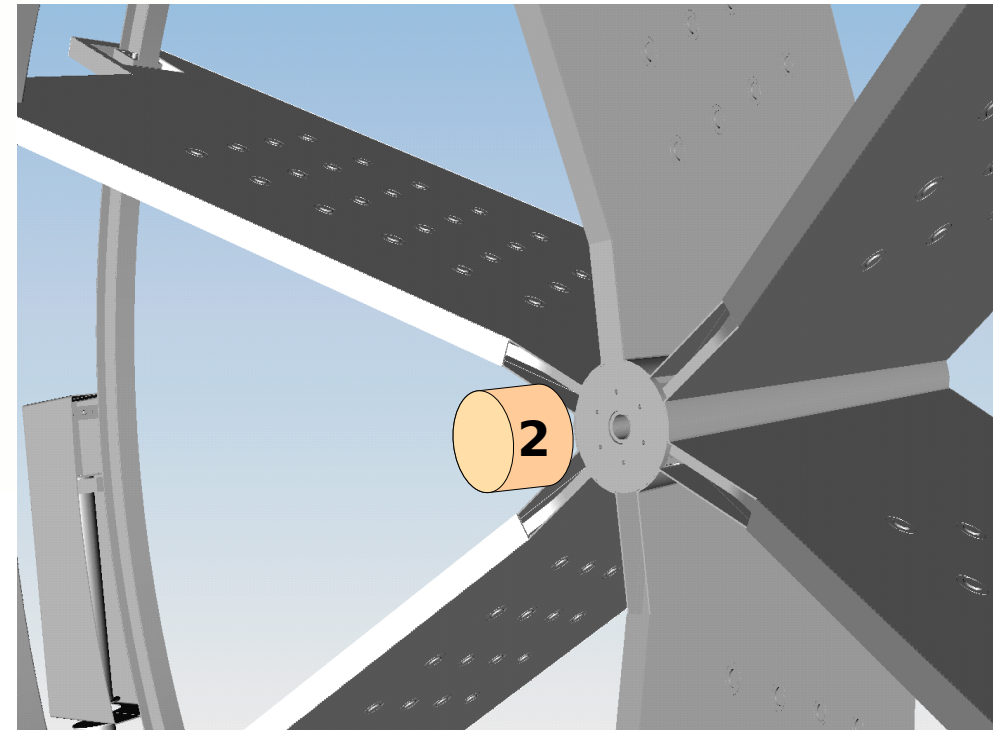

**Maximum electron angle: 0.5°
The tagger has to be placed upstream to torus supports (option 2)**

This strongly limits the possible hardware options

Forward Tagger

Calorimeter + tracking device

Electron Energy/momentum

Photon energy ($\nu = E - E'$)

Polarization $\epsilon^{-1} \sim 1 + \nu^2/2EE'$

PbWO4 crystals

$R_M \sim 2.2$ cm

$\rho \sim 8.3$ g/cm³

$X_0 \sim 0.9$ cm

Low light yield ($\sim 1\%$ NaI(Tl))

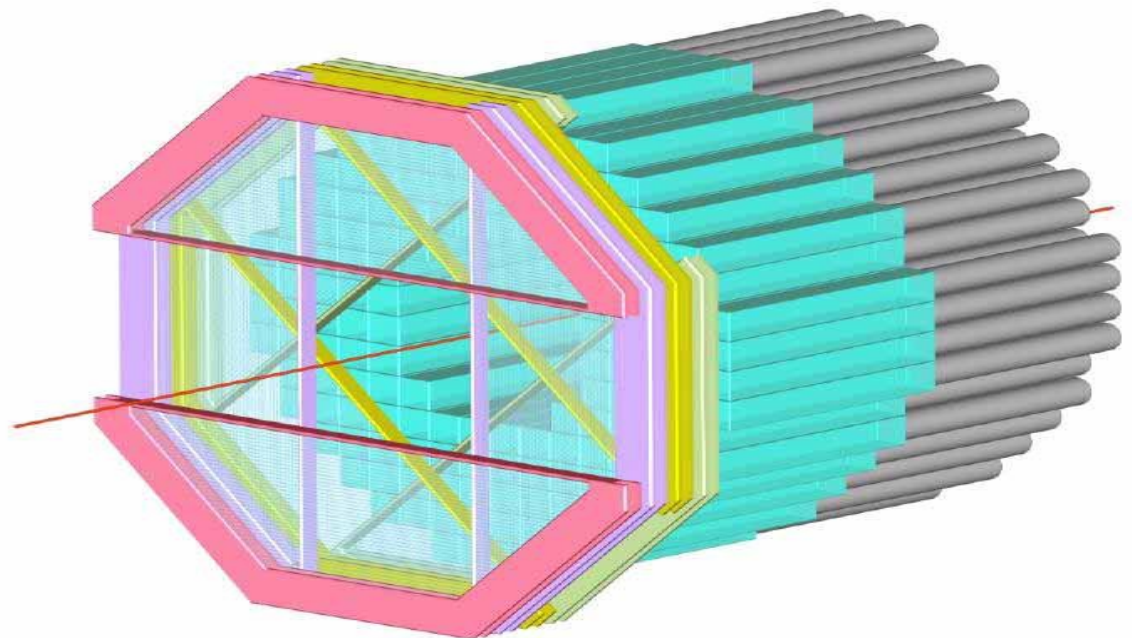

Electron angles

$Q^2 = 4 E E' \sin^2 \vartheta/2$

φ polarization plane

Veto for photons

GEM

Micromegas

SCI-FI hodoscope

Need to estimate resolutions

CLAS Inner Calorimeter

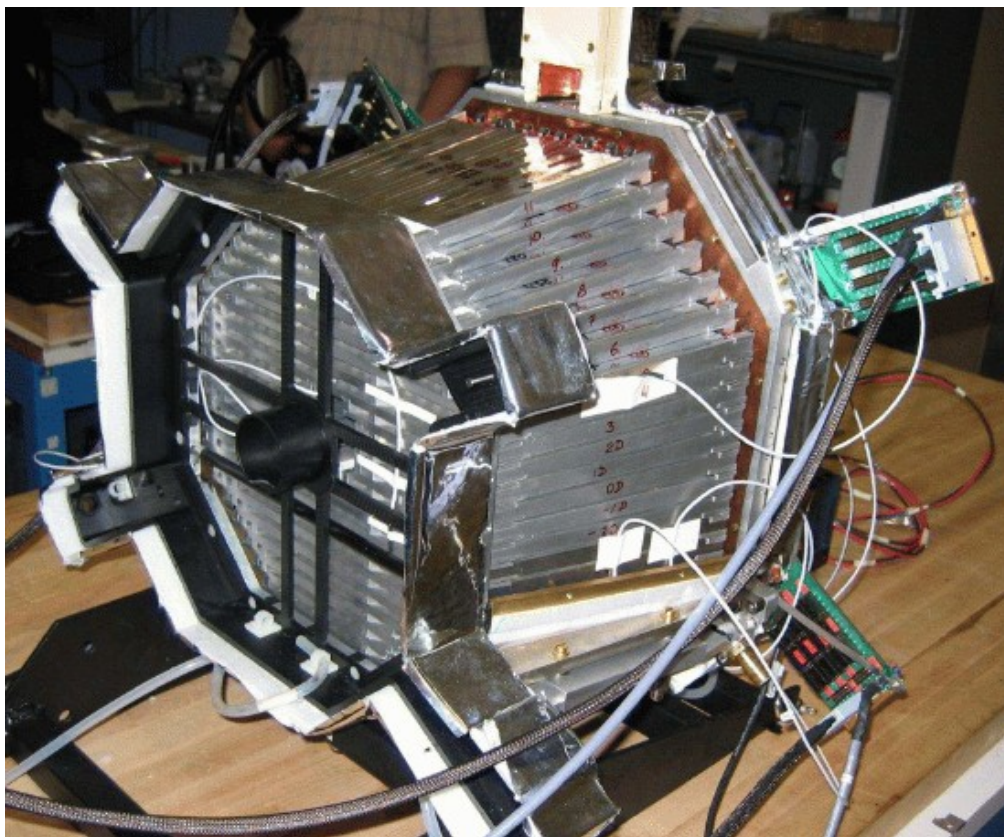

424 PbWO4 crystals
L = 16 cm = 17 X₀
Front size 1.3x1.3 cm²
Back size 1.6x1.6 cm²
Controlled Temperature (0.1 °C)
APD readout

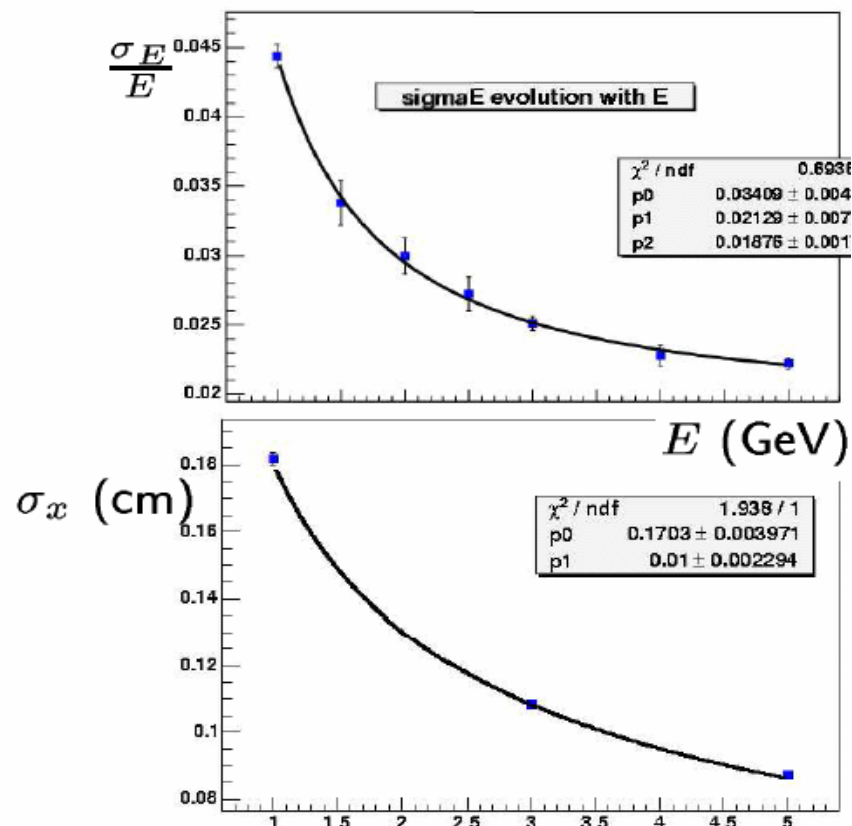

$$\frac{\sigma E}{E} = \frac{0.02}{E} \oplus \frac{0.03}{\sqrt{E}} \oplus 0.024$$

$$\sigma_x = \frac{0.2}{\sqrt{E}} \text{ (cm)}$$

Forward Tagger within CLAS12

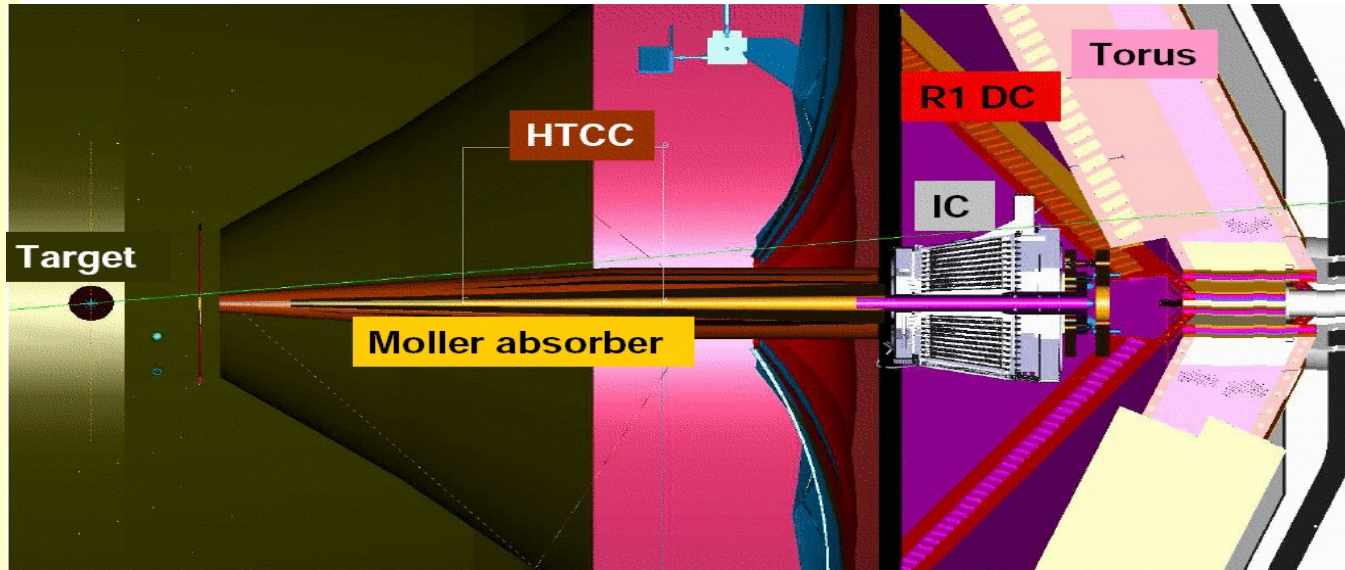

Compatibility with HTCC clearance

- remove HTCC
- no need electron Id
- move HTCC and solenoid upstream (~50cm)
- run parasitically!**

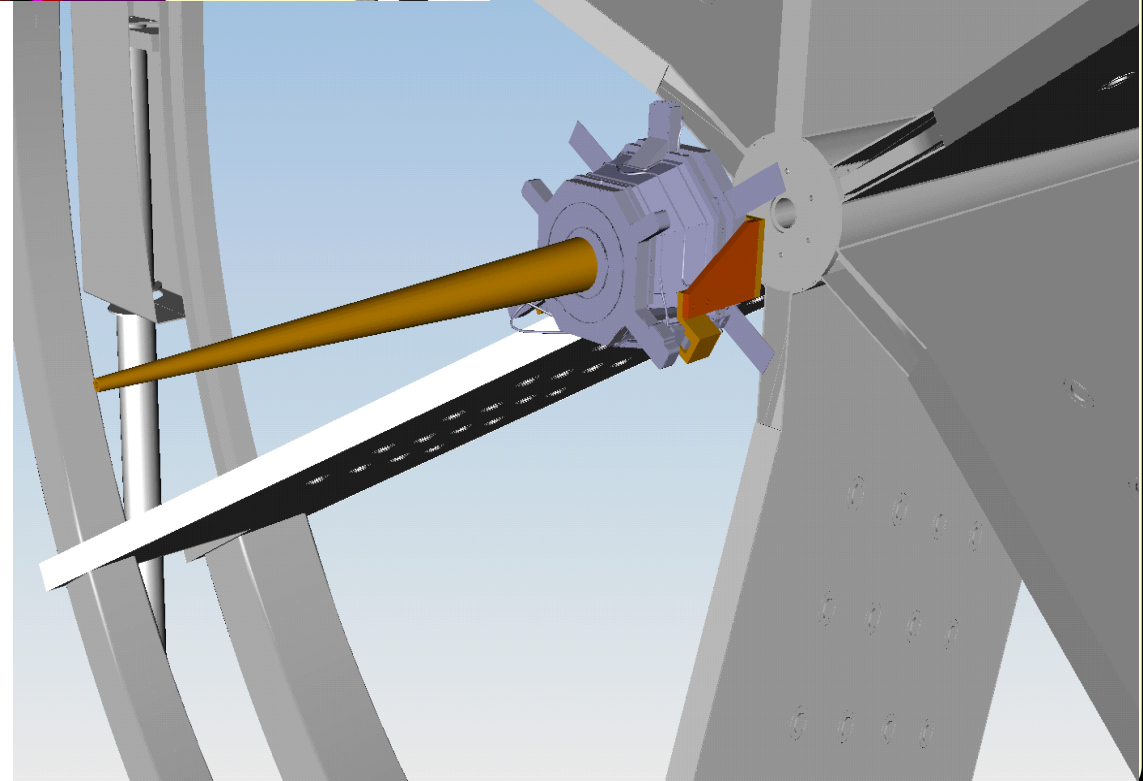
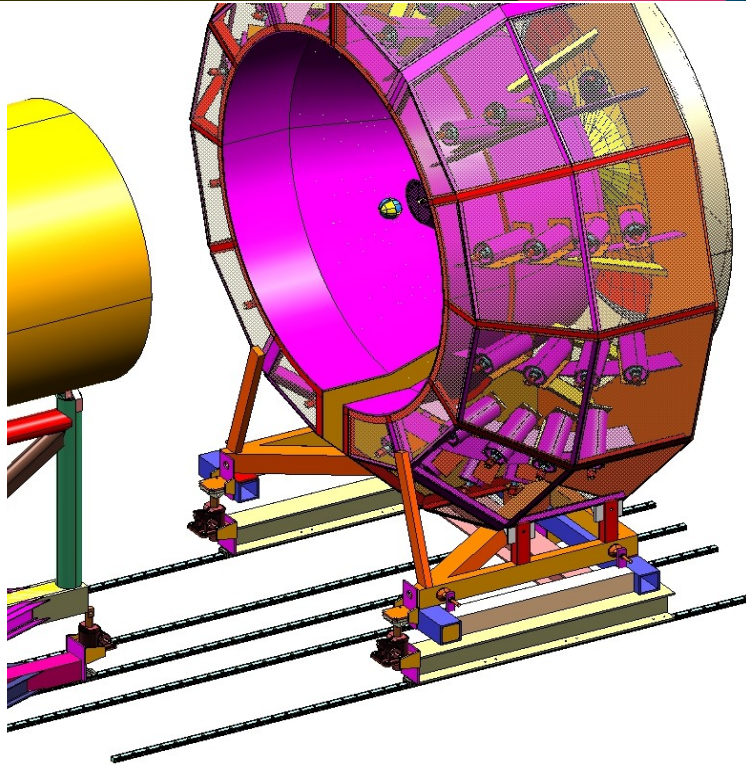
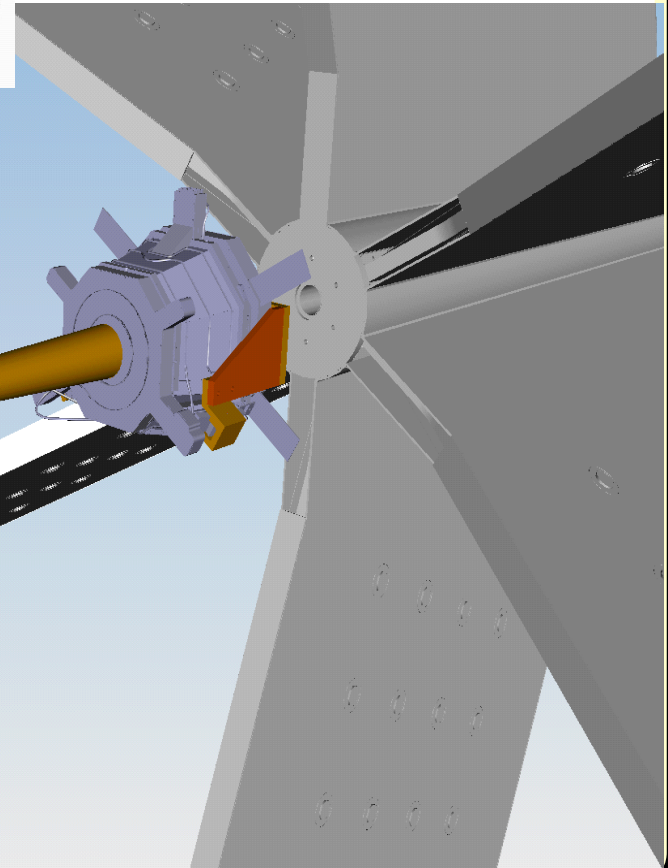

Q^2 dependence of the Xsec

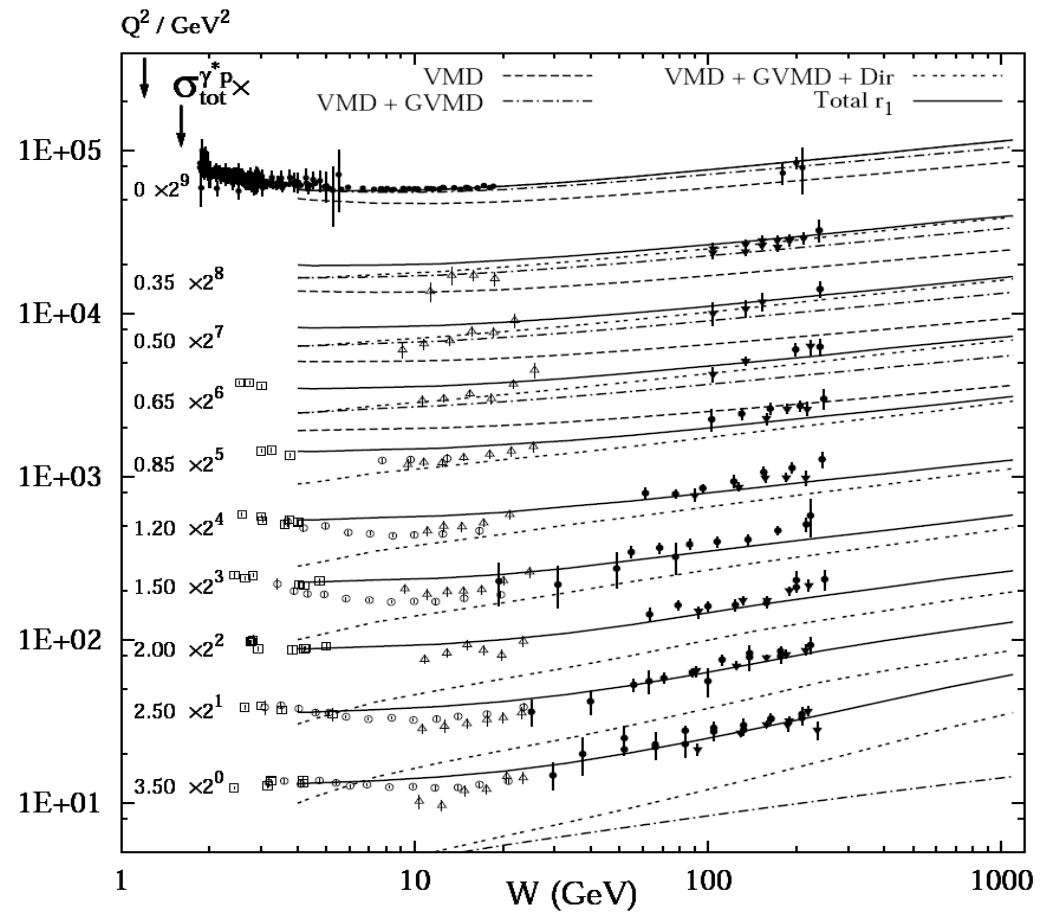
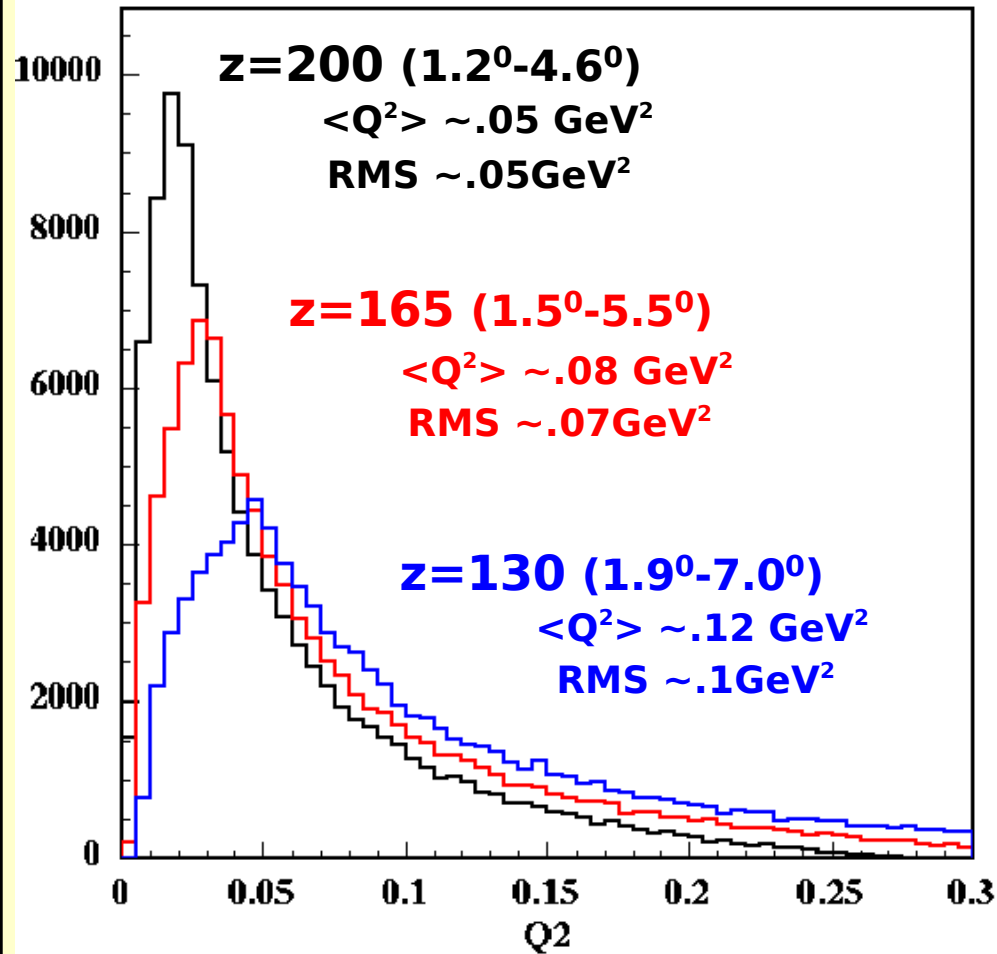

Studies at large W ($\sim 100 \text{ GeV}$) show a smooth transition between $Q^2=0$ and $Q^2 \neq 0$

Existing forward taggers

$$Q^2 < W^2$$

COMPASS:	$<1 \text{ GeV}^2$	$\langle Q^2 \rangle \sim 10^{-1} \text{ GeV}^2$
ZEUS:	$10^{-7} - 0.02 \text{ GeV}^2$	$\langle Q^2 \rangle \sim 5 \cdot 10^{-5} \text{ GeV}^2$
H1:	$<2 \text{ GeV}^2$	

Rates in the forward tagger

Inelastic electro-production

Elastic radiative tail

Moeller scattering

Signal

Background

Rates in the forward tagger

Inelastic electro-production

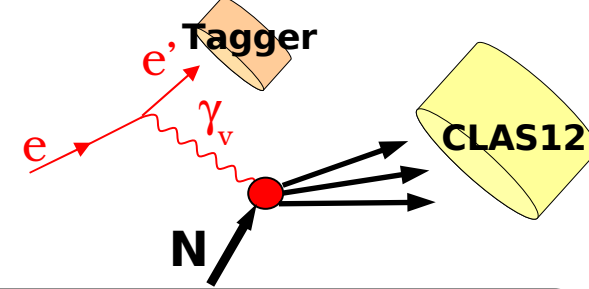

Inelastic electro-production

$\vartheta \ \varphi$ **Scattered electron angles in the Lab**

$\nu = E_{\text{beam}} - E_{e'}$ **Quasi-real photon energy**

$Q^2 = 4 E E' \sin^2 \vartheta/2$ **Virtuality**

$\varepsilon^{-1} \sim 1 + \nu^2 / 2 E_{e'} E_{\text{beam}}$ **Quasi-real photon linear polarization**

$$X_{\text{sec}} = \frac{\Gamma_{\nu}}{(1 + Q^2 / .7^2)^2} \sigma_{\gamma p}$$

$$\Gamma_{\nu} = \frac{1}{137} \frac{E_{e'}}{2\pi^2 E_{\text{beam}}} \frac{W^2 - M_p^2}{2M_p^2} \frac{1}{Q^2} \frac{1}{(1 - \varepsilon)}$$

e' in the forward tagger
hadrons in CLAS12 ($N_h \geq 1$)

Rates are limited to ~10kHz

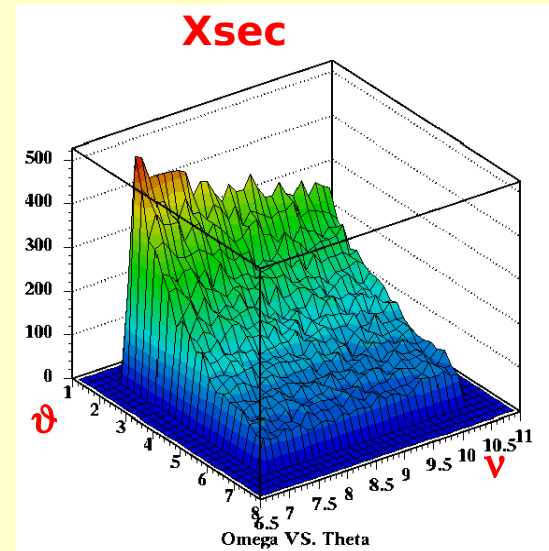
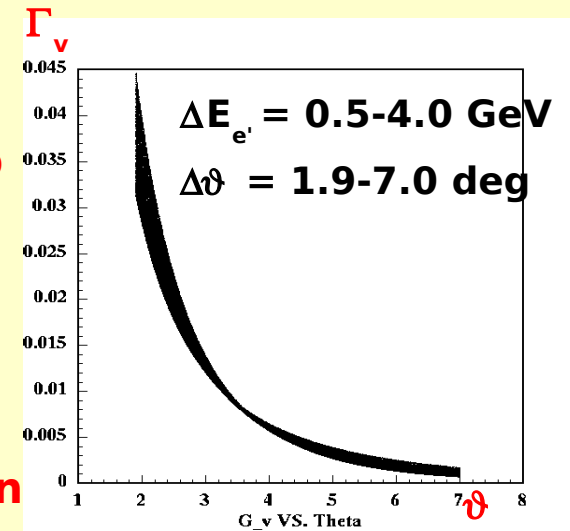

Rates in the forward tagger

Elastic radiative tail

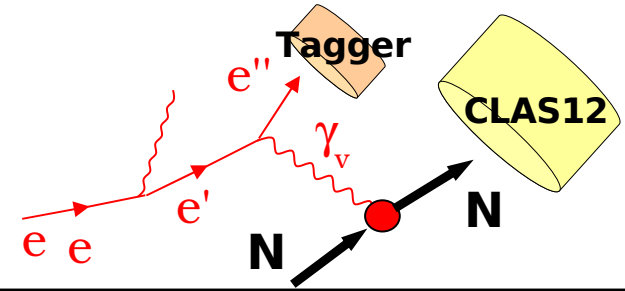

Elastic radiative tail

Electron kinematic

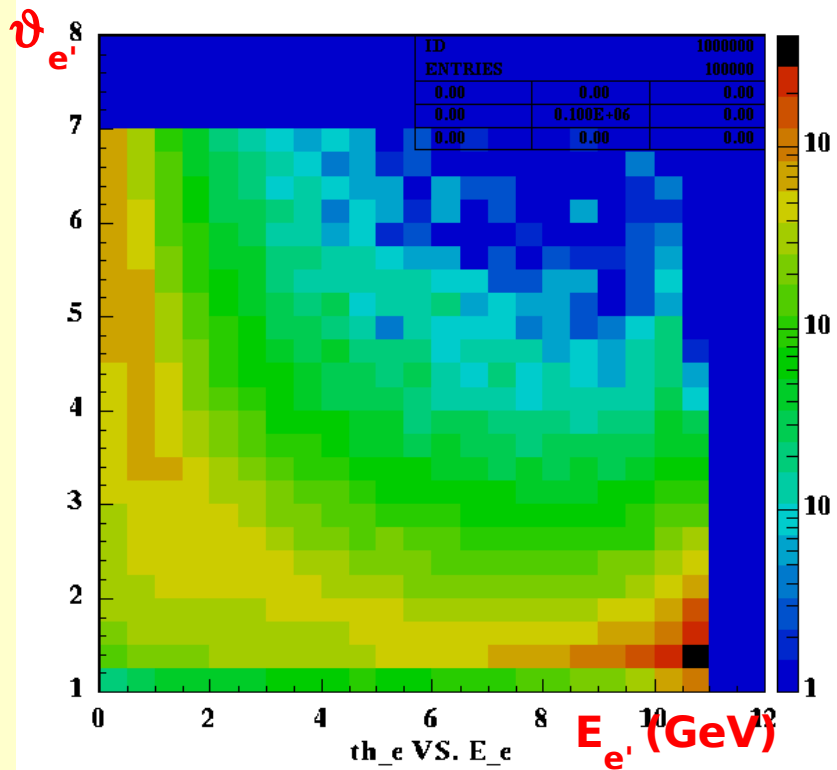

Proton kinematic

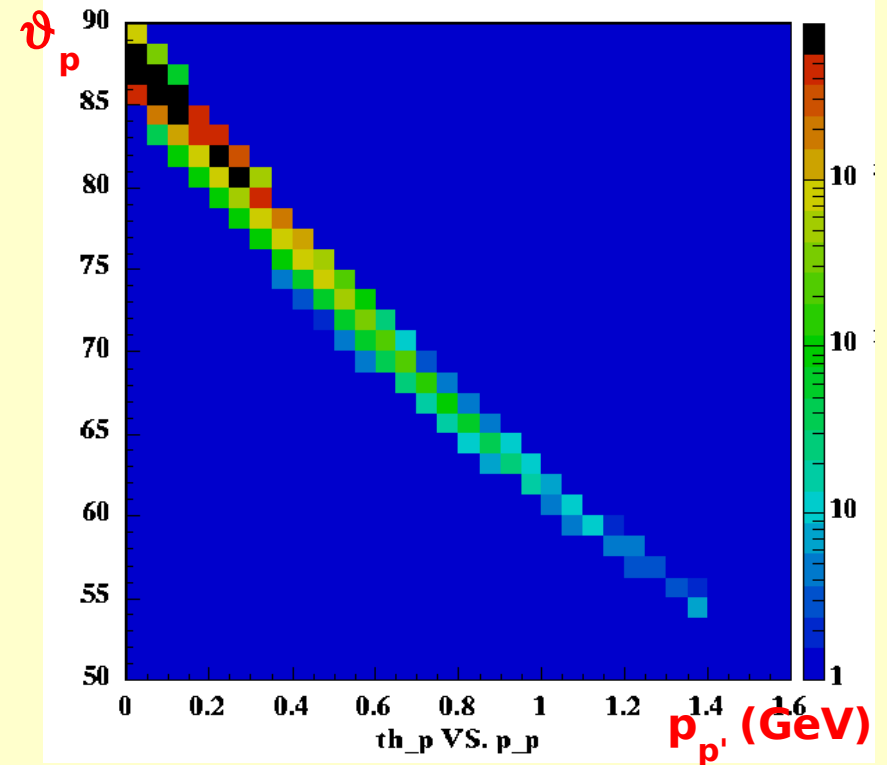

e' in the forward tagger

Elastic proton outside CLAS ($N_h=0$ or 1)

Electron rate in the forward tagger is high (~ 1 MHz)

Rates in the forward tagger

Moeller scattering

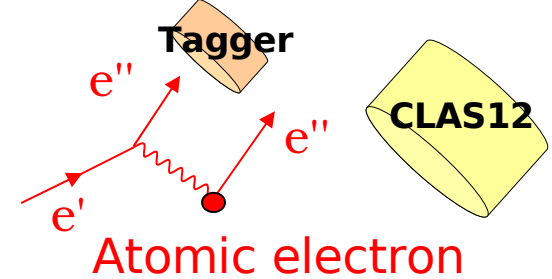

Moeller scattering

kinematics

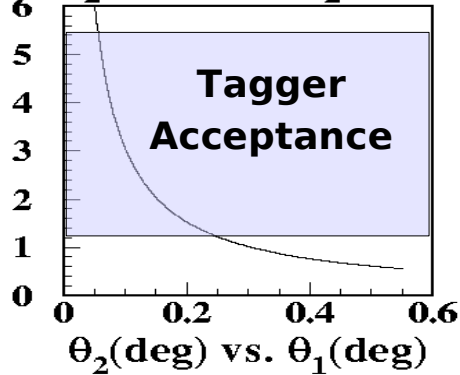
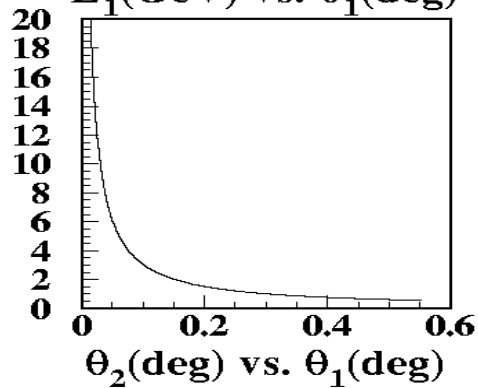
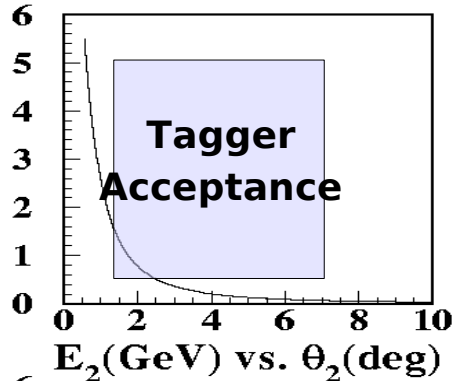
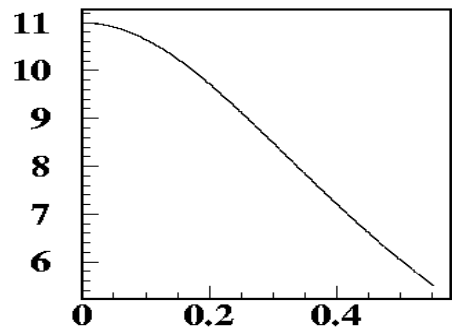

Rate

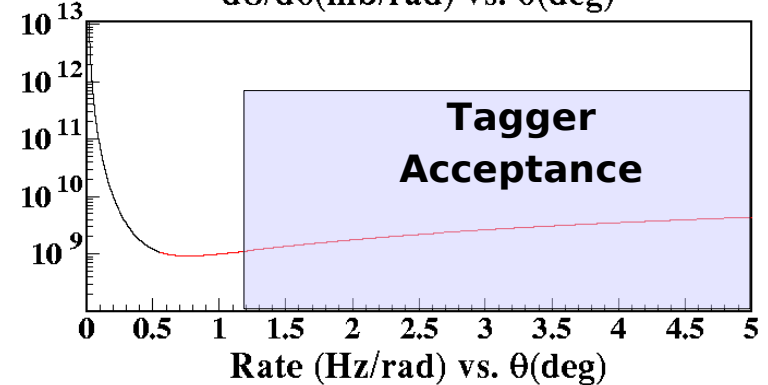
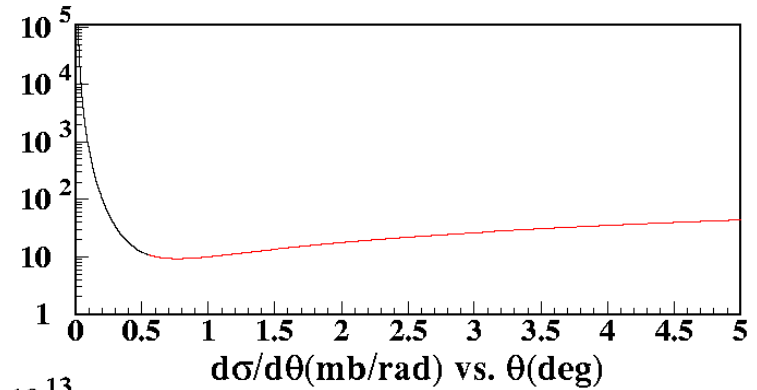

Only 1 electron in the forward tagger

No hits in CLAS ($N_h = 0$)

Electron rate in the forward tagger is very high (~ 50 MHz)

Crystal size: $0.7 \times 0.7 \text{ cm}^2$ First layer: $\sim 20 \times 4$ crystals

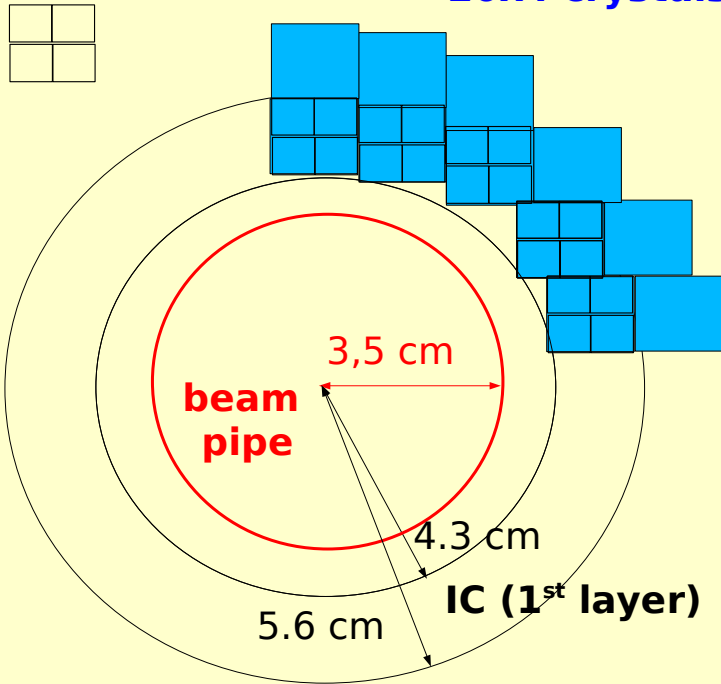

Hadroproduction kinematic

Crystal size = $1.3 \times 1.3 \text{ cm}$
Whole

$N_{\text{crystal}} = 424$

$\Delta\theta = 1.9^\circ - 7.0^\circ$

$\Delta E = 7.0 - 10.5 \text{ GeV}$

Hadro production

Eq. photon flux

First layer

$N_{\text{crystal}} = 20$

$\Delta\theta (1) = 1.9^\circ - 2.5^\circ$

Hadroproduction

Rad tail ($\Delta E = 0.3 - 10.9 \text{ GeV}$)

Moeller

$L = 130, \Delta\theta = 1.9^\circ - 7.0^\circ$

$L_e \sim 10^{35} \text{ cm}^{-2} \text{ s}^{-1}$

$R_e \sim 9.7 \text{ kHz}$

$R_\gamma \sim 0.44 \cdot 10^8 \text{ } \gamma/\text{s}$

$R_e \sim 2.1 \text{ kHz}$

$R_e \sim 1.3 \text{ MHz}$

$R_e \sim 20 \text{ MHz}$

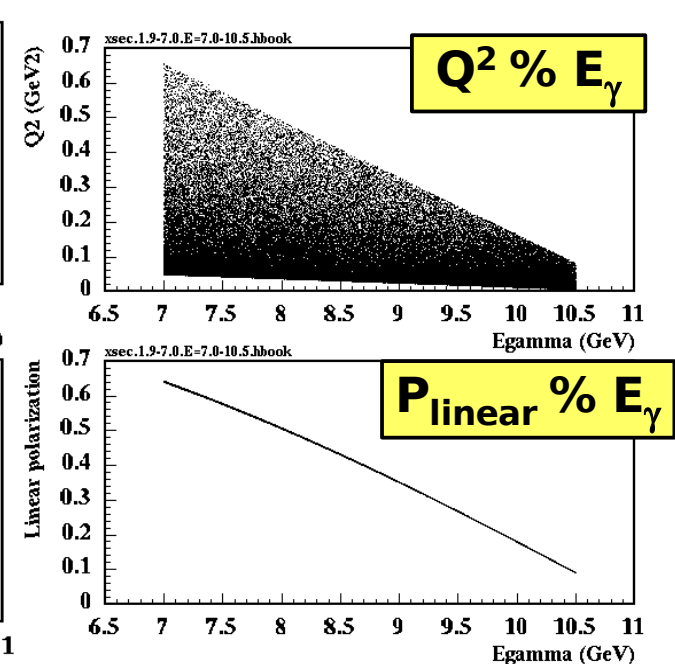
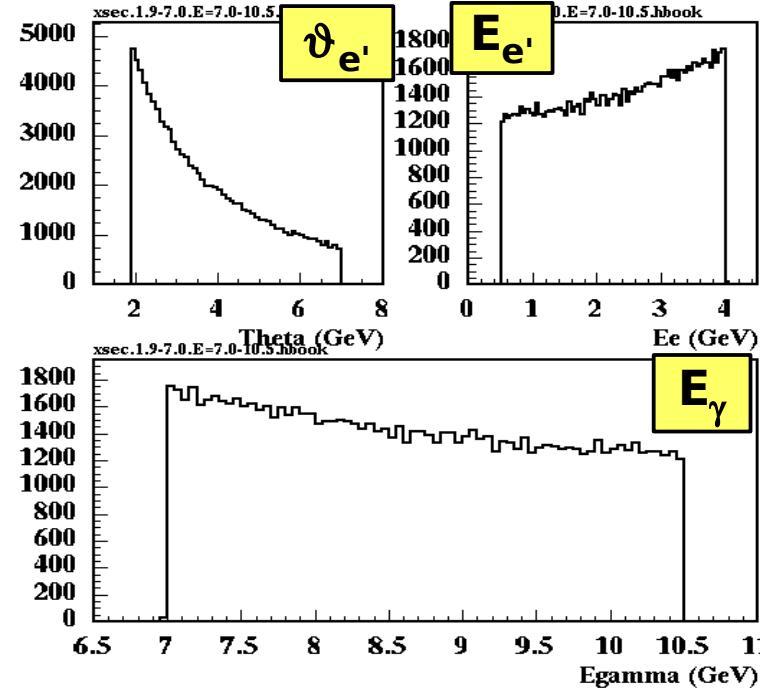
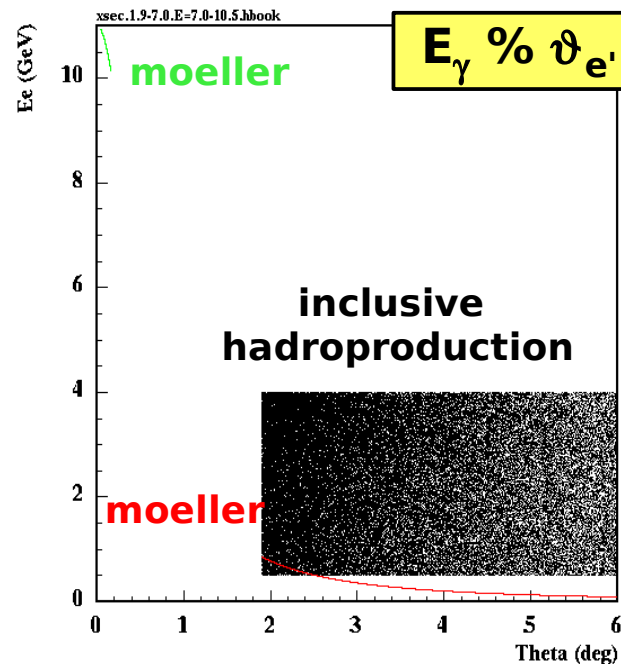

Conclusions

Photoproduction experiments at CLAS12

- ★ Many interesting physics topics with a 10 GeV real photon beam
- ★ We are proposing a forward photon tagging facility
- ★ Complementary technique to the Hall-D coherent Bremsstrahlung
- ★ Compatibility with CLAS12 core and concept design identified
- ★ Tagger will be based on PbWO calorimeter + Tracking
- ★ Just started to evaluate rates, background, and hardware designs

We'd like to invite everybody interested in the physics or the hardware design to join us!