

A large solid angle multiparameter neutron detector

G. Ricco, M. Anghinolfi, P. Corvisiero, E. Durante, S. Maggiolo, P. Prati, A. Rottura and M. Taiuti

Dipartimento di Fisica and INFN-Sezione di Genova, via Dodecaneso 33, 16146, Genova, Italy

Received 28 January 1991 and in revised form 6 May 1991

A 4π neutron detector has been realized using organic scintillators: the detector is suitable for high efficiency, low background measurements of very low neutron rates in the 0.6–5 MeV energy range. Gamma–neutron discrimination has been performed by pulse shape, energy and neutron lifetime analysis and backgrounds have been reduced by anticoincidence detectors and paraffin–lead shielding. Tests of efficiency, energy resolution and radiation identification have been made with a low intensity Am–Be neutron source.

1. Introduction

Recent claims [1] about the so called “cold fusion” have suggested the need for detectors capable of good neutron identification with reasonable sensitivity. The presented system allows a multiparametric neutron identification, measuring at the same time pulse shape, energy and time span of each detected event. In order to ensure a high detection efficiency and sensitivity very close to the values obtained in underground laboratories, the detector surrounds the source with a 4π geometry; the source is placed in a central hole, and large anticoincidence plastic scintillators positioned above the detector allow the reduction of cosmic background. A CAMAC interface transmits all the data to a Micro-VAX computer, which performs the data analysis.

2. Description of the detector

Figs. 1a and 1b show the detector composed of three cylindrical coaxial scintillator shells; each shell is 20 cm long and about 5 cm thick: the inner shell is filled with NE213 liquid scintillator while the outer two are plastic NE102A. The light from the liquid scintillator is collected by seven photomultipliers (Phillips, mod. 2262B), three on the upper and four on the lower surface; the other two scintillators are coupled each with four photomultipliers (Phillips, mod. 2262B for the medium detector and EMI 9805A for the side detector). Cadmium sheets 1 mm thick are interposed between the scintillators and a thinner one (0.5 mm) is wrapped around the central hole (diameter 4 cm) where a 30 cm³ cylindrical sample can be inserted (fig. 1b). The anticoincidence cosmic ray detector is made up of three plastic NE102A

scintillator slabs: the central one $65 \times 30 \times 5$ cm³, the two side ones $65 \times 20 \times 5$ cm³, arranged to form a roof on the detector region, as shown in fig. 1b. The whole system is surrounded in all directions by a shielding composed of an internal layer of 20 cm paraffin (5% enriched in Li₂CO₃) followed by 2 cm electrolytic copper and 10 cm lead.

In order to reduce electronic noise and cosmic ray background the summed anode signals from the liquid scintillator are accepted only when observed: a) in coincidence between the two groups of upper and lower photomultipliers, b) in anticoincidence within a 20 ns interval with the cosmic ray detector. The NE213 light pulse has different decay times when produced by gamma rays or neutrons [2]: a pulse shape discriminator (PSD, Canberra 2160A), operating on the summed anode pulses of the liquid scintillator, separates gamma from neutron events. Since the spectrometer dimensions are relatively large with respect to the mean free path of a few MeV neutrons, a very high fraction of neutrons giving a signal in the liquid scintillator thermalizes and is captured by cadmium foils. Each event (neutron or gamma) releasing energy above the 60 kee (keV electron equivalent, see section 4 and fig. 6) threshold in the liquid scintillator gives the start to a time-to-amplitude converter (TAC, Canberra 2143), that will wait up to 200 μ s for the stop from gamma rays produced by neutron capture on one cadmium sheet and detected by at least one of the three coaxial scintillators. To avoid start and stop pulse pairs produced by the same neutron slowing down in the scintillators, the start pulse is delayed by 500 ns before the TAC input. A neutron event is therefore identified by two trigger signals: the first corresponding to a neutron-type pulse in the liquid scintillator and the second to detection of capture

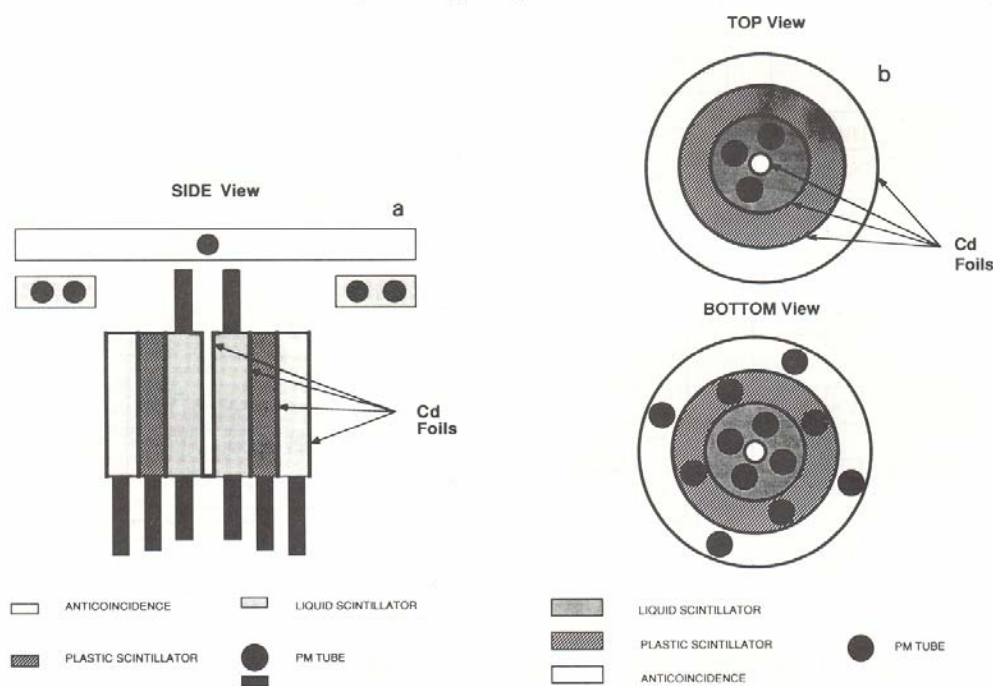

Fig. 1. Spectrometer geometry and composition. (a) Top and bottom view. (b) Side view.

gamma rays within the 200 μ s time window. For each event the linear amplitude of the three scintillator summed anode pulses is also analyzed.

3. Electronics

The conversion and acquisition of those signals (energy signal from the scintillators, pulse shape analysis and n - γ time correlation) necessary to select neutrons and their energy, has been obtained with a LeCroy FERA system composed by a FERA ADC, a FERA driver and two 16 Kbyte Fast Memories. The FERA ADC is dedicated to energy, pulse shape and n - γ time correlation acquisition. Two memories are necessary to permit data-storing through the ECL bus during the CAMAC readout procedure.

A single event acquisition occurs in two steps separated in time:

- a) first the liquid scintillator signal and the signal corresponding to the energy released in the whole calorimeter are converted by the FERA ADC after 100 ns from the event occurrence and then stored in the Fast Memory,

- b) then the signals corresponding to the pulse shape and the n - γ time correlation are converted and stored 200 μ s later.

To perform this task a prompt and a delayed trigger have been realized. The prompt trigger is generated by those events that correspond to a released energy in the liquid scintillator above 60 kee. It is used to generate: i) the ADC gate, 200 ns wide, for the energy acquisition; ii) the start signal for the n - γ time correlation; iii) the TAC start signal for the pulse shape analysis; iv) the TAC strobe signal to synchronize the TAC linear outputs; v) the clear signal for the FERA converter, 12 μ s delayed. The delayed trigger is generated by the SCA output of the TAC employed in the n - γ time correlation and it is used to generate: i) the ADC gate for pulse shape and n - γ time correlation acquisition, ii) the clear signal for the FERA converter, 12 μ s delayed.

The TAC for n - γ time correlation starts to convert on the prompt trigger and stops with the ORed pulse from the three cylindrical scintillators; since the liquid scintillator participates to generate both, the start signal has been 500 ns delayed.

In fig. 2 the trigger logic is presented: in order to minimize the number of utilized devices we have used

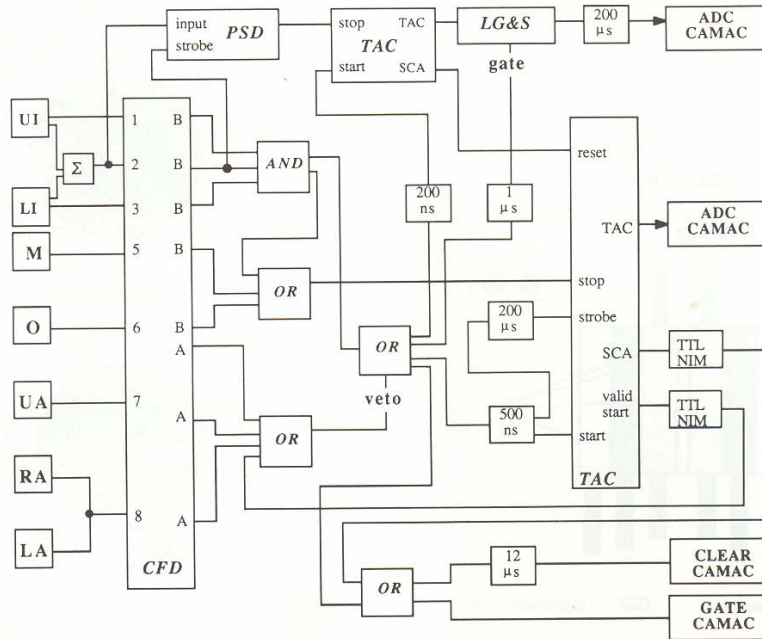

Fig. 2. Trigger logic and circuit scheme. Letters on the left-most column indicate the summed anode pulses of: UI – inner upper photomultipliers, LI – inner lower photomultipliers, M – middle photomultipliers, O – outer photomultipliers, UA – upper anticoincidence photomultipliers, RA – right anticoincidence photomultipliers, LA – left anticoincidence photomultipliers.

an octal EG&G 8000 CFD, two fourfold logic units (LeCroy 365 AL and EG&G 4010) and a Quad Gate and Delay Generator Phillips Scientific 794.

4. Performance of the detector

Cadmium has a high capture cross section for epithermal and thermal neutrons: almost every neutron

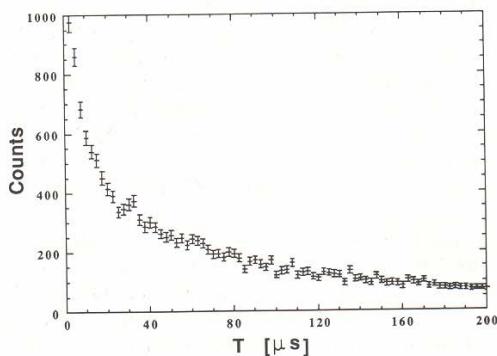

Fig. 3. Neutron lifetime measurement; neutron capture time distribution measured with an Am-Be source. The source emission rate is 2700 n/s; the measuring time is 60 s.

capture on a cadmium sheet is followed by gamma emission (for each capture on the average three gamma rays with a total energy of about 9 MeV are emitted) which is detected, with a high efficiency (83%), by at least one of the three scintillators. If we define as neutron lifetime the time interval between the fast neutron detection in the liquid scintillator (start) and its capture (stop), the lifetime distribution follows a double-exponential slope. In fig. 3 is reported the measured TAC spectrum of the Am-Be source: captures in the epithermal region have a time constant of about 3 μ s while thermal absorptions have a 50 μ s lifetime: the capture time distribution is quite energy independent, at least in the 0.6–5 MeV neutron energy interval, due to the fast energy slowing down to the epithermal region (about 200 ns): in fig. 4 simulated (by a Monte Carlo code [3]) spectra for an Am-Be source and some monochromatic neutrons are reported. The TAC window is open for 200 μ s: in such a time about 95% of the neutrons detected by the liquid scintillators, in the energy range 0.6–5 MeV, are captured by cadmium. Longer time windows would increase the system dead-time in an unacceptable way with little advantage on detection efficiency.

The pulse shape distribution from the pulse shape discriminator (PSD), obtained with an Am-Be source, is shown in fig. 5: the gamma and neutron peaks have a

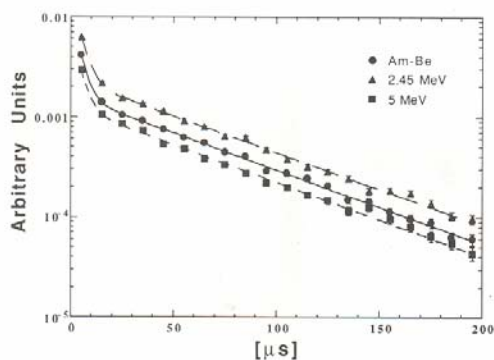

Fig. 4. Neutron captures time distributions, normalized to 100% detection efficiency, for an Am-Be source and monochromatic neutrons as determined by Monte Carlo simulation. Curve fitting gives: $N(t) = 0.095\lambda_1 e^{-\lambda_1 t} + 0.04\lambda_2 e^{-\lambda_2 t}$, $\lambda_2 = 0.30 \mu\text{s}^{-1}$, $\lambda_1 = 0.017 \mu\text{s}^{-1}$ for the Am-Be source; $N(t) = 0.141\lambda_1 e^{-\lambda_1 t} + 0.06\lambda_2 e^{-\lambda_2 t}$, $\lambda_2 = 0.26 \mu\text{s}^{-1}$, $\lambda_1 = 0.017 \mu\text{s}^{-1}$ for 2.45 MeV neutrons; $N(t) = 0.073\lambda_1 e^{-\lambda_1 t} + 0.03\lambda_2 e^{-\lambda_2 t}$, $\lambda_2 = 0.30 \mu\text{s}^{-1}$, $\lambda_1 = 0.017 \mu\text{s}^{-1}$ for 5 MeV neutrons.

FWHM of about 3 ns and 11 ns respectively. The PSD is gated by the TAC output; in this way events characterized by a long pulse duration in NE213 but with a very short lifetime (typically high energy gamma saturated pulses) are rejected. A logic pulse is also produced for each clearly identified gamma event to inhibit the TAC conversion and reduce the detector dead-time (fig. 2); in other words, each start signal not recognized by the PSD as a neutron is rejected.

Plastic and liquid scintillators have a high efficiency for neutron detection but they have a poor energy resolution. Inside the scintillator, the neutrons release their energy in several collisions mainly with hydrogen nuclei; neutrons that thermalize in the spectrometer and

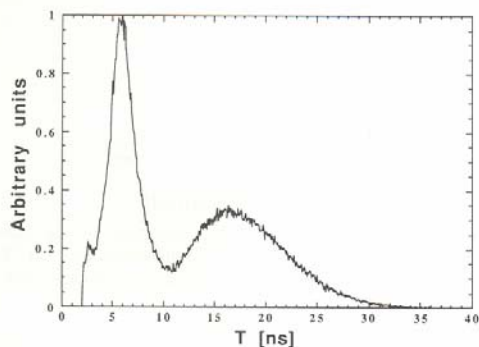

Fig. 5. Pulse shape discrimination: measured crossover time distribution of an Am-Be neutron source. Peak-to-valley ratio is 7.7 and 2.6 for gamma and n peak respectively. Threshold energy was 60 kee.

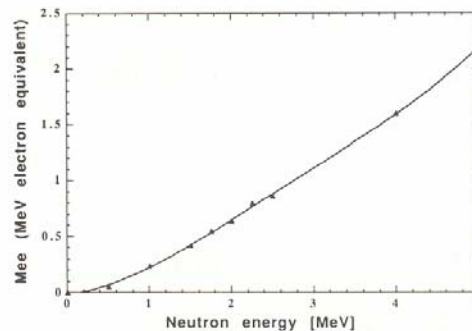

Fig. 6. Mee (MeV electron equivalent) versus neutron energy calculated in the detector energy range (0.6–5 MeV).

are captured by cadmium distribute their energy in at least one of the three scintillators; the anode pulses from the photomultipliers of the three scintillators are therefore summed to obtain the whole energy released in the spectrometer. Since energy released in organic scintillators is calibrated using monochromatic gamma ray sources, MeV electron equivalent (Mee) is generally assumed as energy unit: 1 Mee represents the light collected after 1 MeV energy has been lost by an electron in the scintillator. To show the lower light response to recoil protons, the Mee scale is plotted in fig. 6 against the corresponding energy loss scale for recoil protons in the energy interval of interest for our instrument. The photomultiplier's voltages and the linear amplifications have been optimized to obtain, for every scintillator and for a released energy of 2 Mee, a 250 pC signal at the ADC input, the minimum detectable energy being 0.06 Mee. A 1 Mee energy releasing in the liquid scintillator produces a 1 V height signal at the PSD input which is linear up to 5 V. Energy resolution for gamma rays has been obtained by fitting the experimental spectra of different gamma sources (in the range 0.06–1.9 Mee) with the results of a Monte Carlo code [4] where the intrinsic response function at each energy has been folded with a Gaussian curve. The FWHM values of the Gaussians, which take into account statistical light collection effects, turn out to be about 13% for the liquid scintillator and about 11% for the sum spectrum at 1 MeV. In fig. 7 the spectrum of an Am-Be source, with a neutron emission rate of 2.7×10^3 n/s and a continuous energy spectrum, is compared with the result of a Monte Carlo calculation [3]. The disagreement between measured and calculated data is mostly due to the coincident gamma activity of the Am-Be source (originated by the ${}^9\text{Be}(\alpha, n){}^{12}\text{C}^*$ reaction; gamma energy = 4.44 MeV) which has not been taken into account by the simulation. However, the relative behaviour is in agreement with the hypothesis of a 4.44 MeV gamma ray releasing part of its energy by

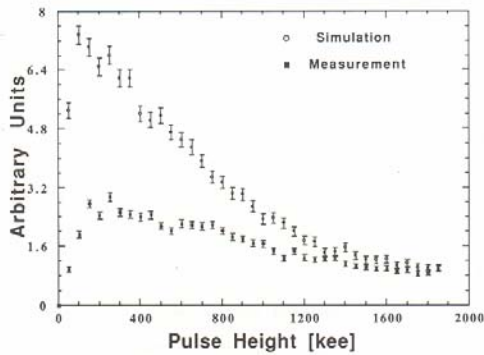

Fig. 7. Am-Be neutron source amplitude spectrum of the sum of the anode pulses from the three scintillators compared with a Monte Carlo simulation: the two spectra are normalized to the highest energy point.

Compton scattering in coincidence with a neutron thermalization. This effect could take into account the unpredicted low energy tail in the experimental spectrum; nevertheless in “cold fusion” measurements where no gammas are produced (if the supposed reaction takes place), this problem does not affect the detector reliability. In fig. 8 a simulated spectrum of 2.45 MeV monochromatic neutrons is displayed; the spectrum has a Gaussian shape centered at about 0.4 Mee and a total variance of 0.15 Mee.

PSD and energy spectra have been joined in the bidimensional plot shown in figs. 9a-9c for a ^{60}Co gamma source, for an Am-Be source and for background: discrimination is definitely improved by the bidimensional analysis and the two gamma and neutron regions can be well separated by an exponential curve.

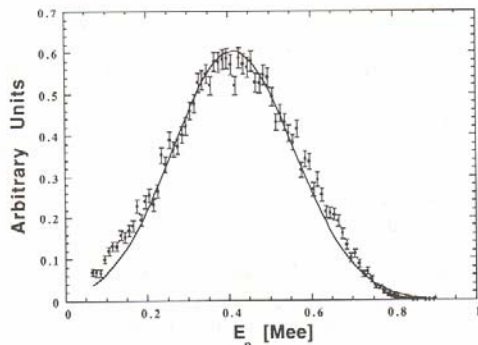

Fig. 8. Simulated spectrum of monochromatic neutrons $E = 2.45$ MeV normalized to 100% detection efficiency. The spectrum is fitted by $f(E_n) = 0.224/(2\pi\sigma^2)^{1/2} \exp(-(E_n - 0.41)^2/(2\sigma^2))$; $\sigma = 0.15$ Mee.

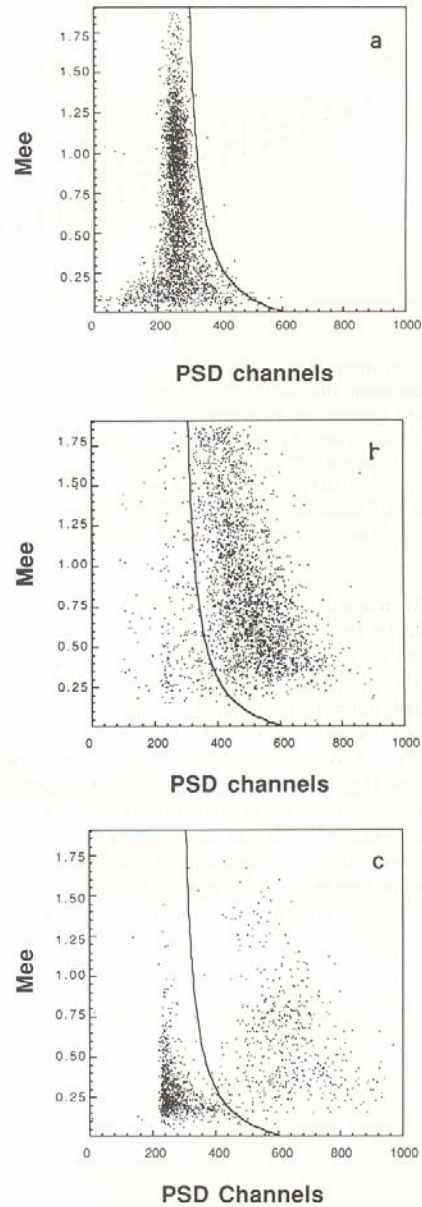

Fig. 9. Correlation between pulse amplitude in the liquid scintillator and PSD output in a two-dimensional plot. (a) ^{60}Co gamma source. (b) Am-Be neutron source. (c) Background.

The neutron detection efficiency has been measured using the calibrated low intensity Am-Be source. The source emits also a great quantity of gamma rays from the decay of excited C levels; in order to avoid effi-

ciency losses, the anticoincidence detectors were deactivated. In the TAC spectrum the random contribution of start and stop pairs inside 200 μ s must be taken into account: this can be done by subtracting from the double-exponential slope (fig. 3) the statistical (random) contribution which reaches asymptotically a constant value. The measured efficiency η is $10 \pm 0.5\%$ for the Am-Be neutron source. The coincident gamma activity of Am-Be increases the detection efficiency (neutrons below the energy threshold may be detected if coincident in the central detector with a low energy gamma pulse produced by a Compton scattering of a 4 MeV gamma ray from ^{12}C deexcitation); this effect was estimated by calculating the 4 MeV gamma detection efficiency (20%) and the fraction of neutrons emitted with energy below 0.06 Mev; even assuming that each of these neutrons were coincident with a gamma, the increase in detection efficiency is less than 0.5%. Efficiency values (10.5% for Am-Be) very close to the experimental ones were obtained with the Monte Carlo simulation. The background level (B), using the shielding quoted in section 2 and averaged on the whole Am-Be energy interval, has been measured to be of the order of 0.02 cps. We may define the detector sensitivity as the lowest detectable neutron rate R_n as:

$$R_n = 3 \frac{\sqrt{B/T}}{\eta},$$

where T is the measuring time; with the quoted η and B values for Am-Be neutrons and $T = 1$ h, R_n is of the order of 0.07 n/s. For 2.45 MeV monochromatic neu-

trons, $B = 0.01$ cps, $\eta = 12.6\%$ (computed by the Monte Carlo code) and the sensitivity turns out to be $2.4(T)^{-1/2}$ n/s.

5. Conclusions

A high sensitivity neutron detector has been realized. Neutrons in the 0.6–5 MeV energy range are identified by a multiparametric analysis, performed by energy and pulse shape discrimination and a TAC with a time window of up to 200 μ s. Background is reduced down to 0.02 cps in the 0.6–5 MeV neutron energy range by a composite passive shielding and anticoincidence detectors. The spectrometer is suitable for the detection of neutrons emitted by a source placed in its center with sensitivity up to 10^{-2} n/s within a few hours measuring time.

References

- [1] S.E. Jones, E.P. Palmer, J.B. Czirr, D.L. Decker, G.L. Jensen, J.M. Thorne, S.F. Taylor and J. Rafelski, *Nature* 338 (1989) 737.
- [2] F.T. Kuchnir and F.J. Lynch, *IEEE Trans. Nucl. Sci.* NS-15(9) (1968) 107.
- [3] M. Anghinolfi, G. Ricco, P. Corvisiero and F. Masulli, *Nucl. Instr. and Meth.* 165 (1979) 217.
- [4] M. Taiuti, M. Anghinolfi, P. Corvisiero, G. Ricco and A. Zucchiatti, *Nucl. Instr. and Meth.* 211 (1983) 135.