

CONVEX FUNCTIONS AND THERMODYNAMIC POTENTIALS

Contents

1 Entropy	1
2 Energy Representation	2
3 Extensivity	4
4 Fundamental Equations	4
5 Convexity	5
6 Legendre transforms	6
7 Reservoirs and Legendre transforms	8
7.1 Heat Reservoir	9
8 Thermodynamic potentials	10
8.1 Gibbs equations	11
9 Thermodynamic Relations and Thermodynamics Stability	13
9.1 Maxwell relations	13
9.2 Thermodynamic derivatives	13
9.3 Thermodynamic inequalities	14
9.4 Physical consequences	15
10 Thermodynamic stability	15

1 Entropy

There exists a function S , called the *thermodynamic entropy*, with the following properties:

- (i) In a simple thermodynamic system, the entropy is a differentiable, concave, extensive function of E, V, N ; it is increasing in E and V .
- (ii) The entropy of a composite system is the sum of entropies of each simple subsystem.
- (iii) If two systems A and B , with initial total energy $E_{\text{tot}} = E_A^i + E_B^i$, are brought into contact and allowed to exchange energy, then the final total equilibrium entropy will be

$$S_{\text{tot}} = \sup_{\substack{E_A, E_B \\ E_A + E_B = E_{\text{tot}}}} [S_A(E_A) + S_B(E_B)] \quad (1)$$

This equation generalizes to more than two subsystems, and when more than one quantity is exchanged.

Definitions of T , p and μ (Gibbs' equation)

$$dS = \frac{1}{T}dE + \frac{p}{T}dV - \frac{\mu}{T}dN. \quad (2)$$

Partial Equilibrium When each subsystem of a composite is in a state of internal equilibrium, but not in equilibrium with the other ones, we say that the composite is in a *partial* (or local) equilibrium state.

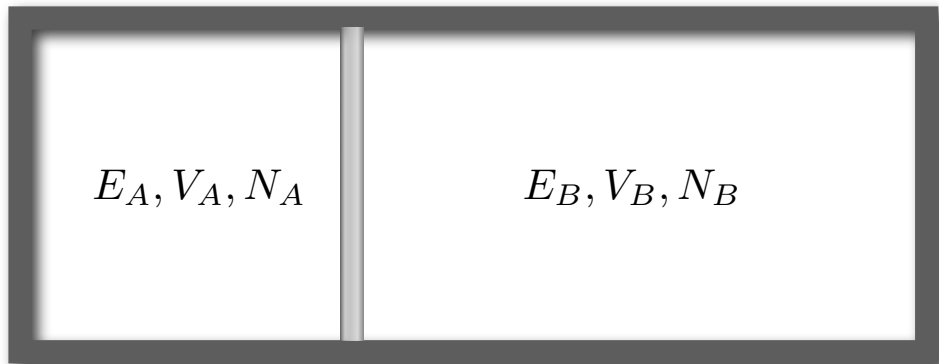

If Y is the variable (or several such variables) that specifies a partial equilibrium state of a composite system, then the entropy of such a state is a function of Y and we shall denote it by $S_{\text{tot}}(Y)$. The maximization of the entropy can be rewritten as

$$S_{\text{tot}} = \sup_Y S_{\text{tot}}(Y). \quad (3)$$

Consider for simplicity only the energy, then

$$S_{\text{tot}}(E_A) = S_A(E_A) + S_B(E_{\text{tot}} - E_A), \quad (4)$$

where S_A and S_B are the equilibrium entropy functions of the two subsystems which are, each one, in a state of internal equilibrium.

Maximization of

$$S_A(E_A, V_A) + S_B(E_B, V_B) = S_A(E_A, V_A) + S_B(E_{\text{tot}} - E_A, V_{\text{tot}} - V_A)$$

yields

$$\frac{1}{T_A} - \frac{1}{T_B} = 0, \quad \frac{p_A}{T_A} - \frac{p_B}{T_B} = 0.$$

Relation with the empirical notion of temperature Suppose that the initial energy E_A^i is near the equilibrium value \bar{E}_A so that we may treat $\Delta E_A = \bar{E}_A - E_A^i$ as a differential. Then

$$\Delta S_{\text{tot}} \approx \left. \frac{\partial S_A}{\partial E_A} \right|_{E_A=E_A^i} \Delta E_A - \left. \frac{\partial S_B}{\partial E_B} \right|_{E_B=E_B^i} \Delta E_A = \left(\frac{1}{T_A^i} - \frac{1}{T_B^i} \right) \Delta E_A \geq 0 \quad (5)$$

Then $\Delta E_A > 0$, if $T_A^i < T_B^i$, i.e., if the initial temperature of A is lower, there will be a heat flow from B to A as long as the temperatures do not equalize. Similarly, if $T_A^i > T_B^i$, then $\Delta E_A < 0$, i.e., A will give energy to B , if its initial temperature is higher. This shows that the above definition of temperature is in agreement with the empirical notion of temperature.

2 Energy Representation

Since $S(E, V, N)$ is invertible with respect to E , the inverse function $E(S, V, N)$ is differentiable, convex, extensive, increasing in S and decreasing in V . Then the

maximization principle of the entropy becomes: If two simple systems A and B , with initial total entropy $S_{\text{tot}} = S_A^i + S_B^i$, are brought into contact and allowed to vary their entropies, then the final total equilibrium energy will be

$$E_{\text{tot}}^{\text{eq}} = \inf_{\substack{S_A, S_B \\ S_A + S_B = S_{\text{tot}}}} [E_A(S_A) + E_B(S_B)] \quad (6)$$

This equation generalizes to more than two subsystems when volume and particles are exchanged between the two system.

Note While the principle of maximum entropy is realized spontaneously in an isolated system when its components are initially not in equilibrium with each other, the energy minimization is not: the transformations that lead to the final state of equilibrium has to be slow enough, that is, *quasi-static*, so that the total entropy remains constant. Be that as it may, regardless of how the equilibrium state is reached, it is important to emphasize that it meets both conditions of maximum entropy and minimum energy.

Entropy Representation

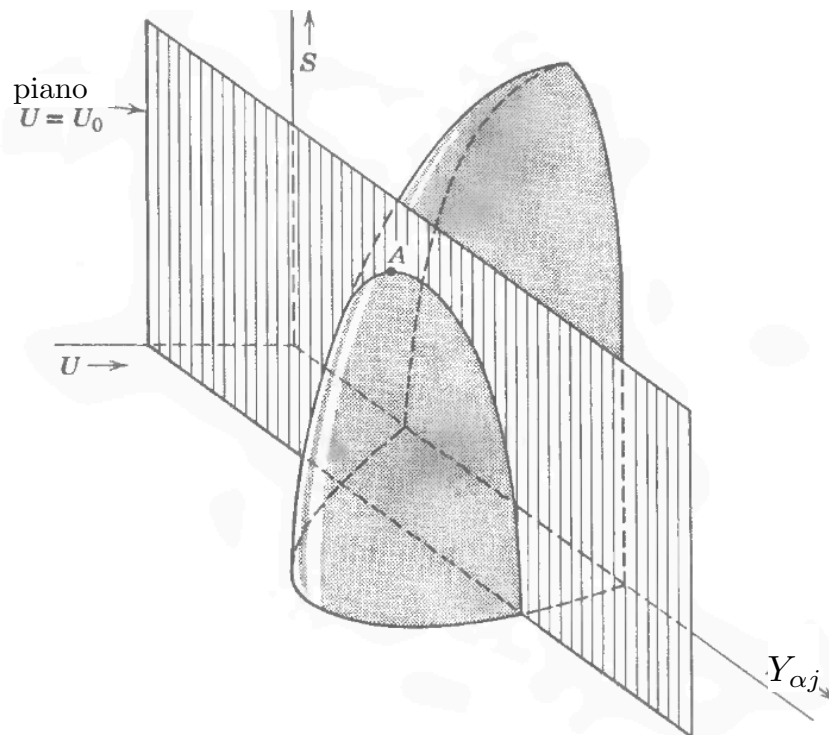

Energy Representation

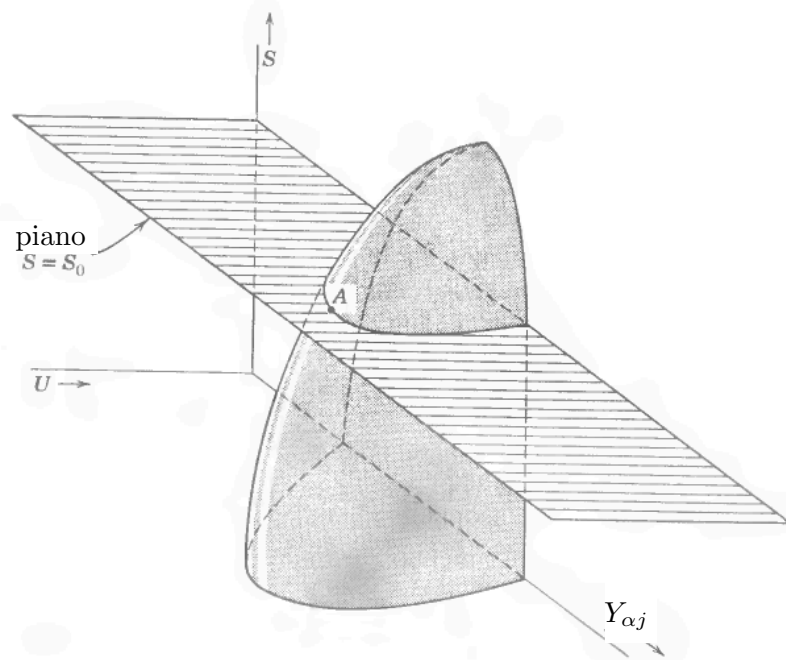

3 Extensivity

$$S(\lambda E, \lambda V, \lambda N) = \lambda S(E, V, N), \quad (7)$$

for any $\lambda > 0$.

Differentiating eq. (7) with respect to λ and taking it at $\lambda = 1$, one gets the Euler equations

$$S = \frac{1}{T}E + \frac{p}{T}V - \frac{\mu}{T}N = \quad \text{or, equivalently,} \quad E = TS - pV + \mu N, \quad (8)$$

which can be read as an integrated version of Gibbs' equation

$$dS = \frac{1}{T}dE + \frac{p}{T}dV - \frac{\mu}{T}dN$$

4 Fundamental Equations

A functional relation between *all* extensive quantities of a thermodynamic system was called by Gibbs its *fundamental equation*.

A fundamental equation determines completely the thermodynamic properties of the system. This is the case for $S = S(E, V, N)$ or $E = E(S, V, N)$. Each one of these two functions determines the temperature, the pressure, the chemical potential, and all the other thermodynamic coefficients of a system, such as its specific heats, compressibility, etc.. In brief, the entropy and the energy functions provide then two equivalent representations of the fundamental equation of a system.

The Gibbs equation in the entropy representation is

$$dS = \frac{1}{T}dE + \frac{p}{T}dV - \frac{\mu}{T}dN, \quad (9)$$

whence the equations of state

$$\frac{1}{T} = \frac{1}{T}(E, V, N) = \left. \frac{\partial S}{\partial E} \right|_{V, N} \quad (10a)$$

$$\frac{p}{T} = \frac{p}{T}(E, V, N) = \left. \frac{\partial S}{\partial V} \right|_{E, N} \quad (10b)$$

$$-\frac{\mu}{T} = \frac{\mu}{T}(E, V, N) = - \left. \frac{\partial S}{\partial N} \right|_{E, V} \quad (10c)$$

This means that p , T , N are not independent like the extensive variables E , V , N , but are constrained by their derivative relations to $S(E, V, N)$, as given by eq. (10).

The pairs $(1/T, E)$, $(p/T, V)$ and $(-\mu/T, N)$ are usually called pairs of conjugate variables in the entropy representation.

Examples

Ideal fluid of van der Waals

$$s = s_0 + k \log \left[(v - b) \left(e + \frac{a}{v} \right)^c \right] \quad (11)$$

where s_0 is a constant.

Electromagnetic radiation

$$S = \frac{4}{3} \sigma^{1/4} E^{3/4} V^{1/4} \quad (12)$$

5 Convexity

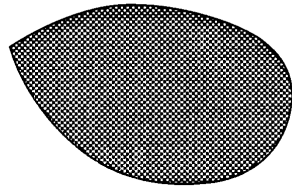

(a)

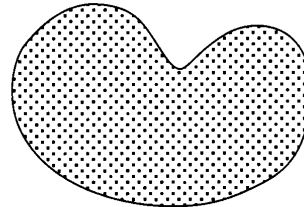

(b)

A subset D of a vector space is *convex* is such that if for any x and y in D also $tx + (1 - t)y$ is in D for every $t \in [0, 1]$. Similarly, a function is convex if its graph curve is always upward,

$$f(tx + (1 - t)y) \leq tf(x) + (1 - t)f(y). \quad (13)$$

Here, the domain D of f is assumed to be a convex set. A function is called strictly convex if the strict inequality holds.

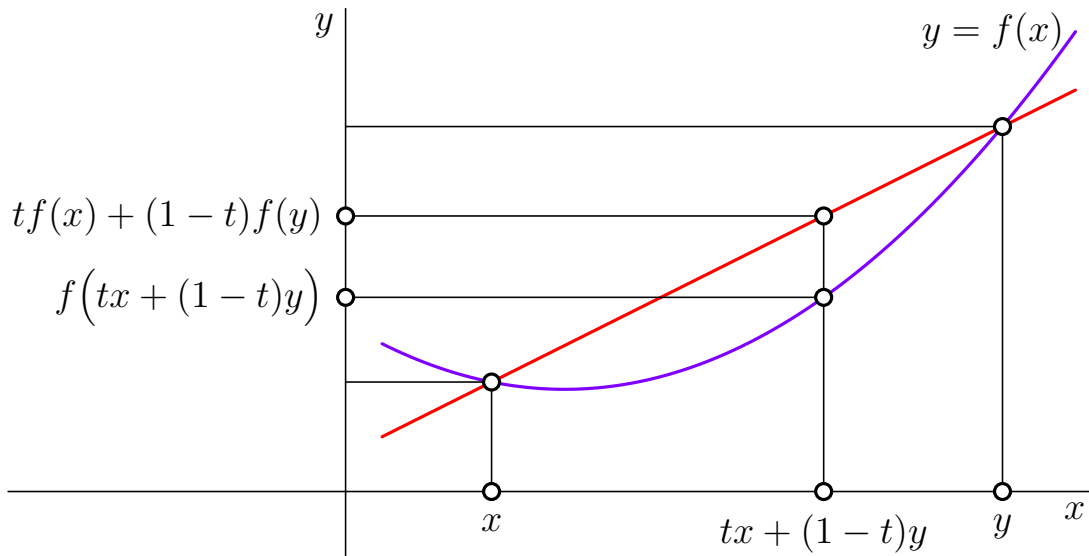

A function g is called *concave* if $-g$ is convex. For a concave function

$$tf(x) + (1-t)f(y) \leq f(tx + (1-t)y) . \quad (14)$$

Note We need to allow functions to take the value $+\infty$. Let $D_{\text{ess}}(f)$ be the essential domain of f , $D_{\text{ess}}(f) = \{x \in \mathbb{R}^n : f(x) < +\infty\}$. One can show that any convex function is continuous in the interior of its essential domain.

Definition The *convex hull* or *convex envelope* of a set X of points in the Euclidean plane or Euclidean space is the smallest convex set that contains X . By convex hull of f we mean the convex hull of the graph of f .

6 Legendre transforms

The LT \mathcal{L} of $f : \mathbb{R}^n \rightarrow \mathbb{R} \cup \{\infty\}$ is $\mathcal{L}(f) = f^* : \mathbb{R}^n \rightarrow \mathbb{R} \cup \{\infty\}$ defined by

$$\mathcal{L}[f](p) = f^*(p) = \sup_x [x \cdot p - f(x)] = -\inf_x [f(x) - x \cdot p] \quad (15)$$

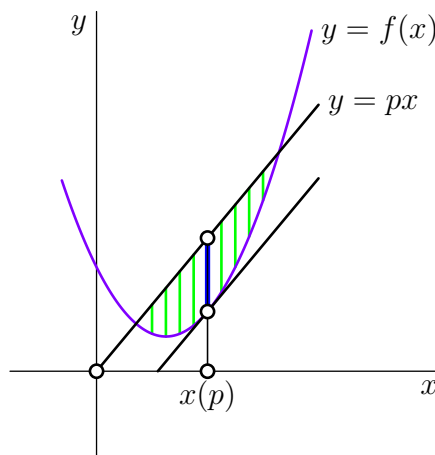

Basic properties (in any dimension):

- (i) The Legendre transform of any function is convex.
- (ii) $f^{**} = f$ whenever f is convex, i.e., on convex functions the operator \mathcal{L} is invertible and $\mathcal{L}^{-1} = \mathcal{L}$. If f is not convex, f^{**} is the convex hull of f .
- (iii) Linear pieces become cusps and conversely.

(i) is easy to show:

$$\begin{aligned}
 f^*(tp + (1-t)q) &= \sup_x [x \cdot (tp + (1-t)q) - f(x)] \\
 &= \sup_x [tx \cdot p - tf(x) + (1-t)xq - (1-t)f(x)] \\
 &\leq t \sup_x [x \cdot p - f(x)] + (1-t) \sup_x [xq - f(x)] \\
 &\leq tf^*(p) + (1-t)f^*(q).
 \end{aligned}$$

(ii) special case: $f(x)$ is differentiable and is strictly convex, that is, convex with no linear parts.

The LT

$$f^*(p) = \sup_x [xp - f(x)]$$

is in general evaluated by finding the critical point x_p which maximizes the function

$$F(x, p) = xp - f(x)$$

Then, we can find the maximum of $F(x, p)$ using the common rules of calculus by solving

$$\frac{\partial}{\partial x} F(x, p) = 0$$

for a fixed value of p . Given the form of $F(x, p)$, this is equivalent to solving

$$p = f'(x)$$

for x given k . Under the stated assumptions there exists a unique maximizer x_p of $F(x, p)$. Thus, we can write

$$f^*(p) = px_p - f(x_p).$$

where

$$f'(x_p) = p$$

Exercise Show that under the stated assumptions $f^{**} = f$.

Legendre duality

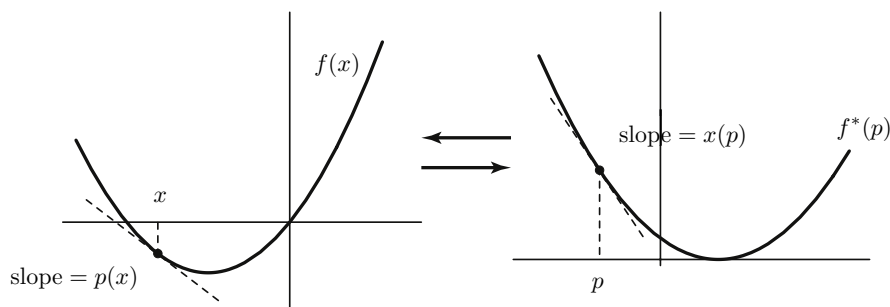

$$f'(x_p) = p \iff f^{*'}(p) = x_p \quad (16)$$

To sum up, when $f(x)$ is differentiable and is strictly convex we have

$$f^*(p) = px_p - f(x_p), \quad (17a)$$

$$f(x) = xp_x - f^*(p_x). \quad (17b)$$

(iii):

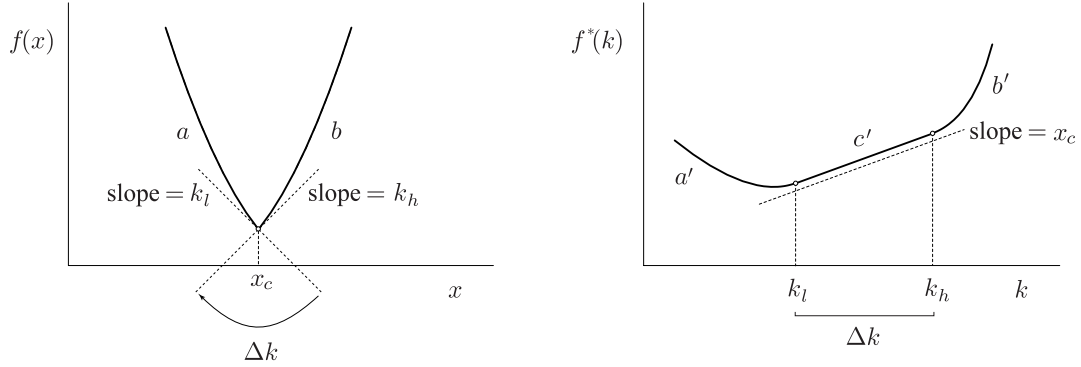

Note A function can be Legendre transformed only with respect to some variables, for example, $f(x, y)$ is transformed only with respect to y . In this case we shall write

$$\mathcal{L}_y[f](q, \dots) = \sup_y [y \cdot q - f(\dots, y)] . \quad (18)$$

Alternative notion of Legendre transform In the applications, it is useful also the following form of Legendre transform

$$\tilde{\mathcal{L}}[f](p) = \inf_x [p \cdot x - f(x)] = - \sup_x [f(x) - p \cdot x] . \quad (19)$$

Since

$$- \sup_x [f(x) - p \cdot x] = - \sup_x [(-p)x - (-f(x))],$$

we have

$$\tilde{\mathcal{L}}[f](p) = -\mathcal{L}[-f](-p). \quad (20)$$

$\tilde{\mathcal{L}}$ has the same properties of \mathcal{L} listed above.

7 Reservoirs and Legendre transforms

A heat reservoir (or heat bath) is a system (in thermal equilibrium) that is so large that to extract any amount of heat from it never affects its temperature T_0 .

A volume reservoir is a system (in mechanical equilibrium) that is so large that to vary its volume never affects its pressure p_0 .

A particle reservoir is a system (in chemical equilibrium) so large that to extract particles from it never affects its chemical potential μ_0 .

The fundamental equation of a reservoir is given by Euler equation (8)

$$S_0(E_0, V_0, N_0) = \frac{1}{T_0} E_0 + \frac{p_0}{T_0} V_0 - \frac{\mu_0}{T_0} N_0 \quad (21)$$

where T_0, p_0 and μ_0 are constants, while the extensive parameters of the reservoir E_0, V_0 , and N_0 may vary when the reservoir interacts with other systems.

7.1 Heat Reservoir

Suppose now that a system is brought in thermal contact with only a heat reservoir over a period of time such it comes eventually to a final state of equilibrium. Since the system interacts only with a heat reservoir, it cannot vary its volume or its number of particles. Furthermore, suppose that its initial temperature T is the same as that of the reservoir T_0 , so that the transformation takes place at constant temperature T . The composite “system + reservoir” is isolated, so that the total energy E_{tot} is constant.

The final equilibrium state corresponds to a maximum of the total partial equilibrium entropy given by eq. (4), which in this case reads

$$S_{\text{tot}}(E) = S(E, \dots) + S_0(E_{\text{tot}} - E, \dots), \quad (22)$$

where $S(E, \dots)$ is the entropy of the system; the dots stand for the other variables V and N which are constants. Since $T_0 = T$ and there is no variation of volume and particle number, we can write eq. (21) as

$$S_0(E_{\text{tot}} - E, \dots) = \frac{E_{\text{tot}} - E}{T} + \text{const} = -\frac{E}{T} + \text{const}, \quad (23)$$

where we have absorbed also the total energy in the constant, whence

$$S_{\text{tot}}(E) = S(E, \dots) - \frac{E}{T} + \text{const}. \quad (24)$$

The final equilibrium state corresponds to the maximum of S_{tot}

$$\sup_E [S_{\text{tot}}(E)] = \sup_E \left[S(E, \dots) - \frac{E}{T} \right] + \text{const}, \quad (25)$$

which is attained at the value $\bar{E} = E(T, \dots)$, solution of the extremum condition

$$\left. \frac{\partial S}{\partial E} \right|_{\dots} (\bar{E}, \dots) = \frac{1}{T}, \quad (26)$$

that is, at the value of energy of the system, for which its temperature is equal to the temperature of the reservoir

Crucially, the function in l.h.s of eq. (25)

$$\Psi(T, \dots) = \sup_E \left[S(E, \dots) - \frac{E}{T} \right] = S(\bar{E}, \dots) - \frac{\bar{E}}{T} \quad (27)$$

depends on T and not on E because the equilibrium, maximized value of the total entropy is not anymore a function of the energy of the system, but only of its temperature, which is equal to that of the reservoir.

Massieu function

The function Ψ defined by eq. (27) is a Legendre transform of the system entropy $S(E)$ in the variable $1/T$,

$$\Psi(T, \dots) = -\tilde{\mathcal{L}}_E[S] \left(\frac{1}{T}, \dots \right). \quad (28)$$

In thermodynamic textbooks, Ψ is called Massieu function (with respect to the energy). From a physical point of view, it is nothing but the total entropy of a system and a heat reservoir in thermal contact, a part from an inessential constant term.

Since S is concave, and the Legendre transform of any function is convex, Ψ is concave, because of the minus sign in the l.h.s of eq. (28). This is of course what was to be expected, given the physical interpretation of Ψ . Since the function Ψ is convex, the transformation eq. (28) is invertible: Ψ and S are related by the Legendre transforms

$$\Psi(T, \dots) = \sup_E \left[S(E, \dots) - \frac{E}{T} \right] \quad (29)$$

$$S(E, \dots) = \inf_{T>0} \left[\Psi \left(\frac{1}{T}, \dots \right) + \frac{E}{T} \right] \quad (30)$$

and the following proposition follows.

The Massieu function $\Psi(T, \dots)$ provides a representation of the fundamental equation of a system equivalent to the one given by the entropy $S(E, \dots)$.

Y	ϑ	Massieu function
E	$\frac{1}{T}$	$S - \frac{E}{T}$
E, V	$\frac{1}{T}, \frac{p}{T}$	$S - \frac{E}{T} - \frac{pV}{T}$
E, N	$\frac{1}{T}, -\frac{\mu}{T}$	$S - \frac{E}{T} + \frac{\mu N}{T}$

8 Thermodynamic potentials

Though Massieu functions play a relevant role in statistical thermodynamics, in the development of classical thermodynamics, other equivalent functions have been introduced. They are defined by

$$-TS_{\text{tot}} = \inf_Y [T\vartheta Y - TS(Y, \dots)] \equiv \Phi(\vartheta, \dots). \quad (31)$$

for different choices of Y . The function Φ so defined is called the *thermodynamic potential* with respect to Y . The following proposition trivially follows from prop. above.

The thermodynamic potentials provide equivalent representations of the fundamental equation of a system.

Useful rewriting putting in evidence energy

$$\Phi(T, \hat{\vartheta}, \dots) = \inf_{\hat{Y}, E} \left[E + T\hat{\vartheta}\hat{Y} - TS(E, \hat{Y}, \dots) \right]. \quad (32)$$

The minimization on E can be turned into a minimization on S , since

$$\inf_{\hat{Y}, E} \left[E + T\hat{\vartheta}\hat{Y} - TS(\hat{Y}, \dots) \right] = \inf_{\hat{Y}, S} \left[E(S, Y, \dots) + T\hat{\vartheta}\hat{Y} - TS \right],$$

whence

$$\Phi(T, \hat{\vartheta}, \dots) = - \inf_{\hat{Y}, S} \left[E(S, Y, \dots) + T\hat{\vartheta}\hat{Y} - TS \right] = -\mathcal{L}_{S,Y} [E] (T, -T\hat{\vartheta}, \dots). \quad (33)$$

From this formula we can read the convexity/concavity properties of the potential: because of the minus sign in front of the Legendre transform, the potential is concave in the variables T and $\hat{\vartheta}$, while is convex in the other extensive variables which are not affected by the Legendre transform (since the energy is convex in all its variables). This is summarized by the following proposition:

The thermodynamic potentials are concave in their intensive variables and convex in their extensive variables.

Most common potentials

(a) $Y = 0$. The potential is the *Helmholtz potential* or free energy

$$F(T, \dots) = -\mathcal{L}_S [E] (T, \dots) = E(\bar{S}, \dots) - T\bar{S} \quad (34)$$

with $\bar{S} = S(T, \dots)$ fixed by the minimization. F is a concave function of T and convex in variables V and N .

(b) $Y = V, T\hat{\vartheta} = p$. The potential is the *Gibbs potential* or Gibbs free energy

$$G(T, p \dots) = -\mathcal{L}_{S,V} [E] (T, -p, \dots) = E(\bar{S}, \dots) + p\bar{V} - T\bar{S} \quad (35)$$

with $\bar{S} = S(T, p \dots)$ and $\bar{V} = V(T, p \dots)$ fixed by the minimization. G is concave in p and T and convex in N .

(c) $Y = N, T\hat{\vartheta} = -\mu$. The potential is the *Landau potential* or grand canonical potential

$$\Omega(T, \mu \dots) = -\mathcal{L}_{S,N} [E] (T, \mu, \dots) = E(\bar{S}, \dots) - \mu\bar{N} - T\bar{S} \quad (36)$$

with $\bar{S} = S(T, \mu \dots)$ and $\bar{N} = N(T, \mu \dots)$ fixed by the minimization. Ω is concave in μ and T and convex in V .

(d) $Y = V, S = \text{constant}, T\hat{\vartheta} = p$. The potential is the *Enthalpy*

$$H(S, p \dots) = -\mathcal{L}_V [E] (p, S, \dots) = E(\bar{S}, \dots) + p\bar{V} \quad (37)$$

with $\bar{V} = V(S, p \dots)$ fixed by the minimization. H is a concave in p and convex in S and N .

In the following, in agreement with the standard notations, we shall drop the bars and write $F = E - TS$, $G = E + pV - TS$, $\Omega = E - \mu N - TS$ and $H = E + pV$. In case of ambiguity is however convenient to restore the “bar” notation.

8.1 Gibbs equations

Consider the differential of the free energy $F = E - TS$

$$dF = dE - TdS - SdT.$$

But

$$TdS = dE + pdV - \mu dT,$$

whence

$$dF = -SdT - pdV + \mu dN. \quad (38)$$

This is the Gibbs equation in the F -representation, from which one reads the equations of state

$$\left. \frac{\partial F}{\partial T} \right|_{V,N} = -S, \quad \left. \frac{\partial F}{\partial V} \right|_{T,N} = -p, \quad \left. \frac{\partial F}{\partial N} \right|_{T,V} = \mu. \quad (39)$$

Similar equations hold for the other potentials.

Second law Maximizing the total entropy of the composite “system + reservoir” is equivalent to minimizing the potential. We can consider more general situations in which the maximization of the total entropy, given by eq. (3), can be turned into a minimization of the potential. The following proposition is nothing but a reformulation of the maximum principle given by the second law.

Let Y' be an internal variable (or a set of variables) that specifies a state of partial equilibrium of a composite in contact with a reservoir at constant ϑ . Then the equilibrium value \bar{Y}' of Y' is that for which the potential $\Phi = \Phi(\vartheta, Y')$ has its minimum value

$$\Phi(\vartheta, \dots) = \inf_{Y'} \Phi(\vartheta, Y') \quad (40)$$

Potential	Gibbs equation	Euler equation
$S(E, V, N)$	$dS = \frac{1}{T}dE + \frac{p}{T}dV - \frac{\mu}{T}dN$	$S = \frac{1}{T}E + \frac{p}{T}V - \frac{\mu}{T}N$
$E(S, V, N)$	$dE = TdS - pdV + \mu dN$	$E = TS - pV + \mu N$
$H(S, p, N)$	$dH = TdS + Vdp + \mu dN$	$H = E + pV = TS + \mu N$
$F(T, V, N)$	$dF = -SdT - pdV + \mu dN$	$F = E - TS = -pV + \mu N$
$G(T, p, N)$	$dG = -SdT + Vdp + \mu dN$	$G = F + pV = N\mu$
$\Omega(T, V, \mu)$	$d\Omega = -SdT - pdV - Nd\mu$	$\Omega = F - \mu N = -pV$

Example: equilibrium of a water droplet in the fog The Landau potential is a natural function of the variables T , μ , and V , and is particularly convenient to use in the analysis of problems involving constant T and μ . Here is an example.

Consider a liquid droplet in some form of continuous medium, such as a fog where there are water droplets in the air. The energy associated with the surface tension is a minimum when the droplet is a sphere, and the droplets can therefore be considered as spherical. There must be a pressure difference between the inside and the outside of the droplets, because otherwise the tendency of the surface tension to contract the the droplet will not be balanced and t there would be no equilibrium. A purely mechanical calculation shows that the pressure difference required to balance the surface tension γ is

$$\Delta p = \frac{2\gamma}{R} \quad (41)$$

for a sphere of radius R . This result was known to Laplace.

We derive eq. (41) using thermodynamic arguments. The total system of interest is formed by the droplet (subscript d), the external medium (subscript e) and the surface (spherical) that separates them. One can not suppose that the number of particles is constant because the particles may evaporate from the droplet in the medium, or condense from the medium on the droplet. In equilibrium, the chemical potential inside and outside are the same, and therefore it is convenient to choose a description of the medium in which it is fixed μ . The only potential we have been introduced that involves μ as independent variable is the Landau potential $\Omega(T, V, \mu)$. With $V_g = 4\pi R^3/3$, $A_d = 4\pi R^2$ for a sphere, and γ a specific function of the temperature, we have the

correct variables to use $\Omega(T, V, \mu)$ as thermodynamic potential, with A considered as a function of V . From Euler's equation

$$\Omega = F - \mu N = -pV$$

for a system in a single volume. In the present case we have three contributions,

$$\Omega = -p_d V_d - p_e V_e + \gamma A_d$$

due to the drop, the external medium and the surface of separation, respectively. In equilibrium, $d\Omega/dR$ must be equal to zero. We have

$$\frac{dV_d}{dR} = 4\pi R^2 = -\frac{dV_e}{dR}$$

(the sum of V_d and V_e remains constant when the radius of the drop changes) and $dA_d/dR = 8\pi R$. Thus, we have

$$\frac{d\Omega}{dR} = -(p_d - p_e)4\pi R^2 + \gamma 8\pi R = 0$$

The result eq. (41) follows with $\Delta p = p_d - p_e$.

9 Thermodynamic Relations and Thermodynamics Stability

We shall now review the basic thermodynamic relations which can be easily obtained by means of the thermodynamic potentials and related them to the basic condition of thermodynamic stability.

9.1 Maxwell relations

The so-called Maxwell relations are the equations that arise from the equality of the mixed partial derivatives of the fundamental equation expressed in any of the various possible representations. They can be read directly from the table above. For example, from the differential of G (at N constant), one reads

$$\left. \frac{\partial V}{\partial T} \right|_p = - \left. \frac{\partial S}{\partial p} \right|_T . \quad (42)$$

This is one of the Maxwell relations, the others follow similarly.

9.2 Thermodynamic derivatives

The first derivative of the fundamental equations provide the equations of state of the system and are given by either the intensive variables p, T, μ or by extensive variables S, E, V, N , in the right combination and dependence on the other variables. For example in the G -representation we have

$$S = S(T, P, N), \quad V = V(T, p, N), \quad \mu = \mu = \mu(T, p, N).$$

The second derivatives of the fundamental equation describe the properties of the materials which are of direct experimental interest. They are usually well known for many materials and tabulated, in particular those that are functions of p and T . Here are the basic ones (for constant N):

$$\text{molar heat capacity at constant pressure} \quad c_p = \frac{T}{N} \left. \frac{\partial S}{\partial T} \right|_p = -\frac{T}{N} \left. \frac{\partial^2 G}{\partial T^2} \right|_p \quad (43a)$$

$$\text{coefficient of thermal expansion} \quad \alpha = \frac{1}{V} \left. \frac{\partial V}{\partial T} \right|_p = -\frac{1}{V} \left. \frac{\partial S}{\partial p} \right|_T = \frac{1}{V} \left. \frac{\partial^2 G}{\partial p \partial T} \right|_T \quad (43b)$$

$$\text{isothermal compressibility} \quad \kappa_T = -\frac{1}{V} \left. \frac{\partial V}{\partial p} \right|_T = -\frac{1}{V} \left. \frac{\partial^2 G}{\partial T^2} \right|_p \quad (43c)$$

The last equality for each coefficient has been obtained from the Maxwell relations in the G -representation. For systems of constant N , all other second derivatives can be expressed in terms of these three, in particular, the following ones, which are of practical interest:

$$\text{molar heat capacity at constant volume} \quad c_v = \frac{T}{N} \left. \frac{\partial S}{\partial T} \right|_V = -\frac{T}{N} \left. \frac{\partial^2 F}{\partial T^2} \right|_V \quad (44a)$$

$$\text{adiabatic compressibility} \quad \kappa_S = -\frac{1}{V} \left. \frac{\partial V}{\partial p} \right|_S = -\frac{1}{V} \left. \frac{\partial^2 H}{\partial p^2} \right|_S \quad (44b)$$

Using Maxwell relations, it can be shown that

$$c_v = c_p - \frac{TV\alpha^2}{N\kappa_T} \quad (45a)$$

$$\kappa_S = \kappa_T - \frac{TV\alpha^2}{Nc_p}. \quad (45b)$$

Finally, we leave as an exercise to show that the molar heat capacities are also given by the equations

$$c_v = \left. \frac{\partial U}{\partial T} \right|_V, \quad c_p = \left. \frac{\partial H}{\partial T} \right|_p, \quad (46)$$

which relate more directly to their measurements, and that eq. (45) implies

$$c_p/c_v = \kappa_T/\kappa_S. \quad (47)$$

9.3 Thermodynamic inequalities

From the convexity properties of the potentials, some physically relevant inequalities follow. To see how this comes about, let us consider a system at constant N , so that there are only two independent variables.

Concavity of entropy The second law establishes that the entropy is concave in all its natural variables. Such a global conditions entails local conditions for its second derivatives—they must be non positive—and its Hessian—it must be non negative—that is,

$$\left. \frac{\partial^2 S}{\partial E^2} \right|_V \leq 0, \quad \left. \frac{\partial^2 S}{\partial V^2} \right|_E \leq 0, \quad \left. \frac{\partial^2 S}{\partial E^2} \right|_V \left. \frac{\partial^2 S}{\partial V^2} \right|_E - \left(\left. \frac{\partial^2 S}{\partial V \partial E} \right|_E \right)^2 \geq 0. \quad (48)$$

Convexity of energy The energy is globally convex in all its natural variables, therefore its second derivatives must be non negative and its Hessian must be non positive

$$\left. \frac{\partial^2 E}{\partial S^2} \right|_V \geq 0, \quad \left. \frac{\partial^2 E}{\partial V^2} \right|_S \geq 0, \quad \left. \frac{\partial^2 E}{\partial S^2} \right|_V \left. \frac{\partial^2 E}{\partial V^2} \right|_S - \left(\left. \frac{\partial^2 E}{\partial V \partial S} \right|_S \right)^2 \leq 0. \quad (49)$$

Convexity/concavity of the Helmholtz potential With respect to the volume, the Helmholtz potential maintains the convexity property of the energy, while the minus sign in from of the Legendre transform indicates that it is a concave function of T . Thus,

$$\left. \frac{\partial^2 F}{\partial V^2} \right|_T \geq 0, \quad \left. \frac{\partial^2 F}{\partial T^2} \right|_V \leq 0, \quad (50)$$

Concavity of the Gibbs potential The Gibbs potential is globally concave. Thus,

$$\left. \frac{\partial^2 G}{\partial T^2} \right|_p \leq 0, \quad \left. \frac{\partial^2 G}{\partial p^2} \right|_T \leq 0, \quad \left. \frac{\partial^2 G}{\partial p^2} \right|_T \left. \frac{\partial^2 G}{\partial T^2} \right|_p - \left(\left. \frac{\partial^2 G}{\partial p \partial T} \right| \right)^2 \geq 0. \quad (51)$$

Convexity/concavity of the enthalpy With respect to the entropy, the enthalpy is convex, but concave as a function of the pressure. Thus,

$$\left. \frac{\partial^2 H}{\partial S^2} \right|_p \geq 0, \quad \left. \frac{\partial^2 H}{\partial p^2} \right|_S \leq 0, \quad (52)$$

9.4 Physical consequences

The most important physical consequences of the thermodynamic inequalities are summarized by the following proposition:

The addition of heat, either at constant pressure or constant volume, necessarily raises the temperature of a system — more for a process at constant volume than for one at constant pressure. And the decrease in volume, whether isothermal or isentropic, necessarily increases its pressure—more for an isothermal process than for an isentropic one.

Let us prove this proposition. By comparing eq. (44) with eq. (50) and eq. (52), we infer that

$$c_v \geq 0, \quad \kappa_S \geq 0, \quad (53)$$

while the comparison of eq. (43) with eq. (51) gives

$$c_p \geq 0, \quad \kappa_T \geq 0. \quad (54)$$

From eq. (45a) and eq. (47), we finally obtain

$$c_p \geq c_v \geq 0 \\ \kappa_T \geq \kappa_S \geq 0,$$

10 Thermodynamic stability

If the entropy were not concave, equilibrium would not be stable.

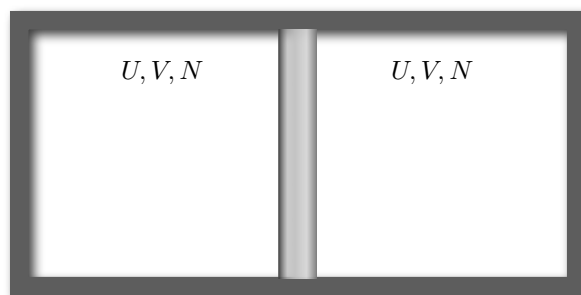

To show this, let us consider two identical systems, each with fundamental equation $S = S(E)$, in a container with rigid and adiabatic walls. In the middle of the container is placed a piston.

By symmetry, pressures and temperatures to the right and left of the piston are equal, therefore the system is in equilibrium. We expect it to remain in this state as long as the constraints are not modified. However, if the dependence of the entropy on the energy were like this

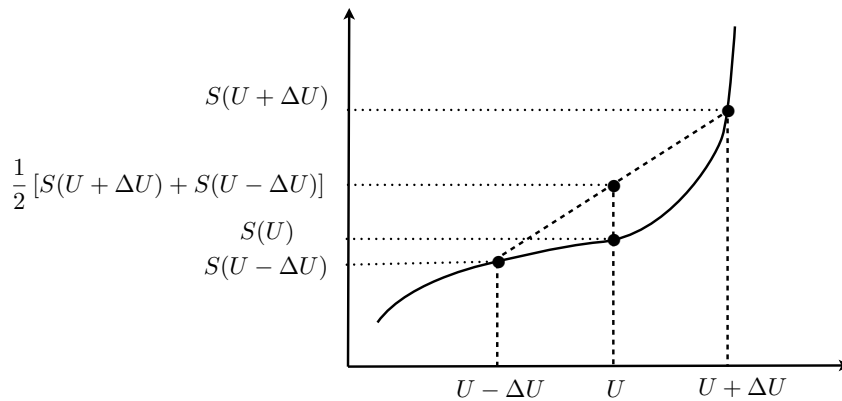

this would not happen: there would be a transfer of energy ΔE from one system to another because the entropy value corresponding to this exchange, $S(E + \Delta E) + S(E - \Delta E)$, would be higher than the initial value $2S(E)$. So that the equilibrium states are stable it is therefore necessary that S is a concave function of energy, i.e., such that, for any value of E and ΔE ,

$$S(U + \Delta E) + S(U - \Delta E) \leq 2S(U).$$

which is indeed the condition of concavity of eq. (14) (for $t = 1/2$, $x = E + \Delta E$, $y = E - \Delta E$).